

MULTI CYCLONE 70XL

Manual



WARNING

This equipment must be installed and serviced by a qualified technician. Improper installation can create electrical hazards which could result in property damage, serious injury or death. Improper installation will void the warranty.



Notice to Installer

This manual contains important information about the installation, operation and safe use of this product. Once the product has been installed **this manual must be given to the owner / operator of this equipment.**

Table of Contents

SAFETY INFORMATION	00
INTRODUCTION	01
INSTALLATION	02
PLUMBING CONNECTION	02
FILTER MAINTENANCE	03
FLUSHING OUT THE SEDIMENT CHAMBER	03
WARRANTY	03
TECHNICAL SPECIFICATION	04
DIMENSIONS	04
EXPLODED DIAGRAM	05

SAFETY INFORMATION

1. MultiCyclone 70XL is designed to work with water at temperatures greater than 0° C and less than 45°C. The filter should never be operated outside of these temperatures or damage may occur.
2. The installation should be carried out in accordance to the safety and the specific instructions for each facility.
3. Any modification of the filter requires the prior consent from Waterco. Original replacement parts and accessories authorized by the manufacturer ensure a high level of safety. Waterco assumes no liability for the damage and injuries caused by unauthorised replacement parts and accessories.
4. The user should make sure that the installation is carried out by qualified authorised persons and that these persons have first carefully read the following instructions.
5. The operating safety of the filter is only guaranteed if the installation and operation instructions are correctly followed.
6. In the event of defective operation or fault, contact Waterco or its nearest authorised service agent.
7. To reduce the risk of injury, do not permit children to use this product unless they are closely upervised at all times.
8. Incorrectly installed equipment may fail, causing severe injury or property damage.

INTRODUCTION

MultiCyclone 70XL is capable of saving water and reducing filter maintenance.

The MultiCyclone 70XL works on the basis of centrifugal water filtration. There are no moving parts to wear and tear, and no filter media to clean or replace.

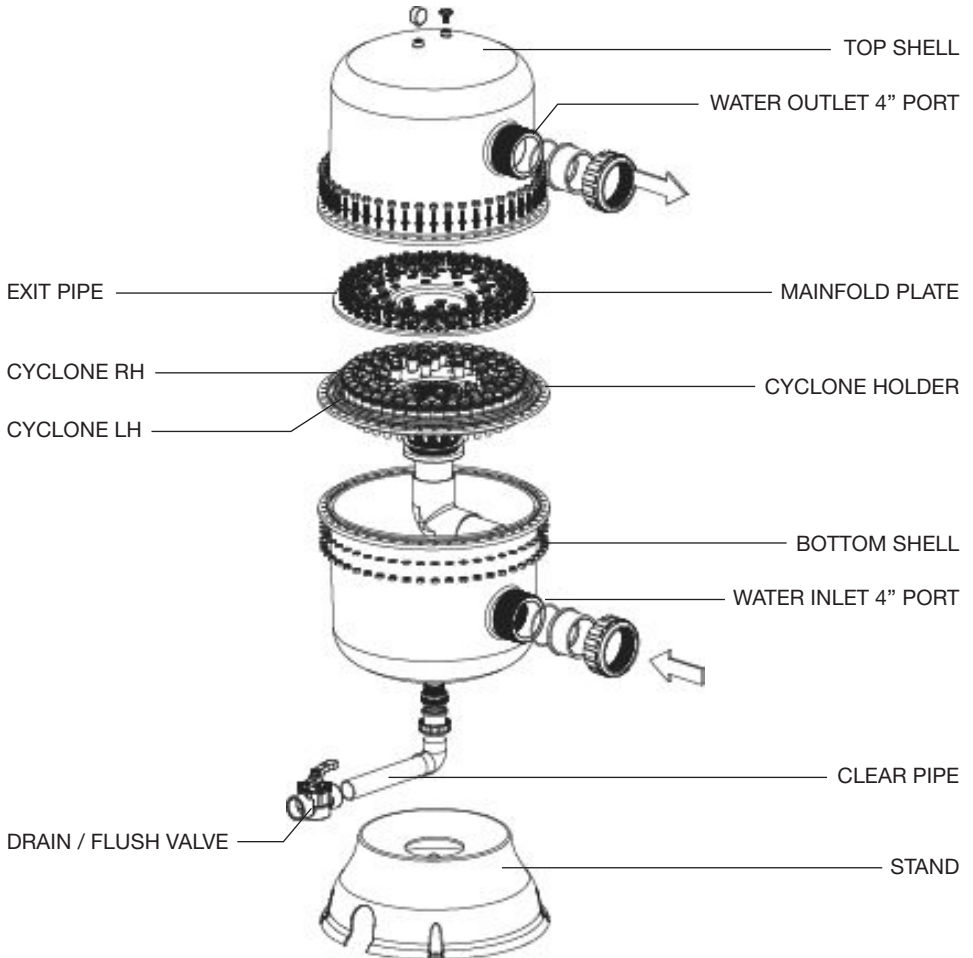

Incoming water is guided by a diverter plate so that it enters multiple hydro cyclones tangentially generating a strong centrifugal effect. This spins the sediment out to the hydro cyclone's wall and then spirals it down to the sediment chamber, while the cleansed water spirals upwards.

The accumulation of sediment can be visibly monitored through the MultiCyclone 70XL's clear sight glass. The MultiCyclone 70XL is cleaned by simply opening the purge valve.

MultiCyclone 70XL is ideal as a pre-filter to extend the life of your existing filter.

- Save Water
- Reduce backwash frequency.

Please Note: The MultiCyclone 70XL is designed to filter sediment that is heavier than water; floating debris cannot be filtered out by centrifugal filtration.

INSTALLATION

Be sure to comply with the local plumbing codes. The filter may be plumbed into a drinking water system and would, therefore be subject to whichever local regulations that may apply.

Be sure that all provisions for wastewater disposal meet local, state or national codes. Do not discharge water where it will cause flooding or damage.

If the incoming water pressure is higher than the maximum operating pressure of 250kPa /2.5Bar /36 psi, a Pressure Regulating Valve (PRV) must be installed upstream of the filter inlet.

The PRV should be set to 90% of the maximum operating pressure of the tank.

If the incoming water flow is less than the filter's minimum flow requirements, the filter's filtration efficiency will be affected, please consult Waterco.

MultiCyclone 70XL Recommended Operational Flow Rates

Minimum flow rate: 36m³/hr (158.5 GPM)

Maximum flow rate: 96 m³/hr (422.7 GPM)

PLUMBING CONNECTION

1. Connect the outlet from your pump to the inlet of the MultiCyclone 70XL.

Glue the plumbing to the Barrel unions and Allow 24 hours for glue (solvent) to set. Ensure solvents are not excessively applied to fittings as this could run into o'rings and create sealing problems. Screw the barrel union on to the inlet of your MultiCyclone 70XL and hand tighten.

2. Connect from the outlet of the MultiCyclone 70XL to the inlet of your filter.

Glue the plumbing to the Barrel unions and Allow 24 hours for glue (solvent) to set. Ensure solvents are not excessively applied to fittings as this could run into o'rings and create sealing problems. Screw the barrel union on to the outlet of your MultiCyclone 70XL and hand tighten.

3. Connect to Waste Line.

Glue the plumbing from the Sediment Purge Valve to your waste line.

4. Turn on pump.

Be sure to check that there are no leaks from the connectors. If required, tighten by hand.

FILTER MAINTENANCE

Filter maintenance determined by the following conditions:

1. The flow rate through the MultiCyclone 70XL is insufficient to meet the demand.
2. The sediment chamber is half filled with sediment.

The accumulation of sediment can be visibly monitored through the MultiCyclone 70XL's clear sight glass. The MultiCyclone 70XL is cleaned by simply opening the purge valve

FLUSHING OUT THE SEDIMENT CHAMBER

Whilst the water pump is running simply open the sediment purge valve until the sediment has been flushed out. This is visible through the clear sight glass.

Once the sediment has been flushed out, close the sediment purge valve.

WARRANTY

MultiCyclone 70XL is covered by a 2 warranty.

For more information please refer to the Waterco "Warranty Terms & Conditions" booklet. With our on going commitment to quality products and service Waterco Limited reserves the right to alter the product in any manner and at any time without prior warning.

This information is to the best of our knowledge, accurate at the time of printing. Any recommendations or suggestions are made without warranty and without prejudice, since the use of our product is beyond our control.

TECHNICAL SPECIFICATION

Pressure Rating: 250 kPa / 2.5 bar /36 psi

Minimum Flow Rate: 36m³/hr (158.5 GPM)

Maximum Flow Rate: 108 m³/hr (475.6 GPM)

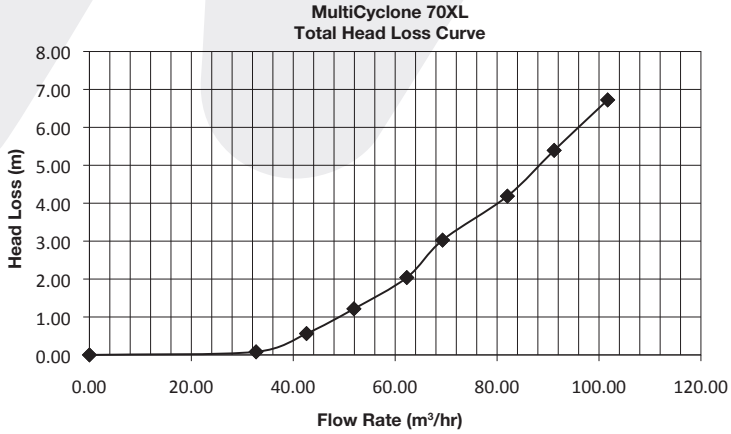

DIMENSIONS

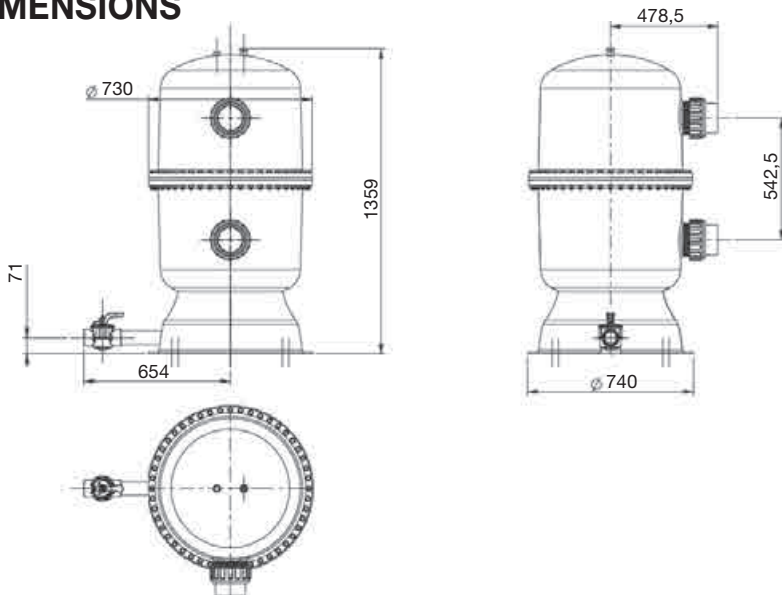

EXPLODED DIAGRAM

NO	DESCRIPTION	QTY
34	Nut M6 (Not Shown)	40
33	Rubber Washer (Not Shown)	1
32	O Ring BS 112	1
31	Air Relief Valve	1
30	Bolt M10	48
29	Bolt M6	40
28	Washer M6	40
27	O Ring BS 009	40
26	O Ring BS 018	70
25	O Ring BS 025	14
24	O Ring BS 392	1
23	O Ring Special	2
22	Washer BH 100mm	2
21	O Ring BS 474	2
20	Washer M10	96
19	Nut M10	48
18	Clear Pipe 50mm	1
17	2 Way Valve 50mm	1
16	Base	1
15	Elbow 50mm	1
14	Half Union 50mm	1
13	Male Valve Socket	1
12	Lower Shell	1
11	Pipe 100mm	1
10	Elbow 90° 100mm	1
9	Pipe 100mm	1
8	Bulkhead 100mm	1
7	Cyclone Holder	1
6	Cyclone Cone RH	35
5	Cyclone Cone LH	35
4	Mainfold Plate	1
3	Exit Pipe / Vortex Tube	70
2	Half Union 100mm	2
1	Top Shell	1

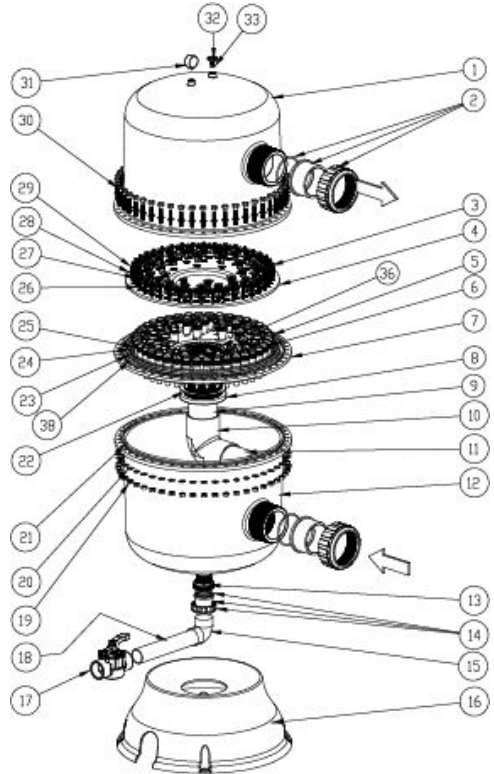

OFFICES - AUSTRALIA

NSW - SYDNEY
(HEAD OFFICE)
Tel: +61 2 9898 8600

QLD - BRISBANE
Tel: +61 7 3299 9900

VIC/TAS - MELBOURNE
Tel: +61 3 9764 1211

WA - PERTH
Tel: +61 8 9273 1900

SA/NT - ADELAIDE
Tel: +61 8 8244 6000

ACT DISTRIBUTION
Tel: +61 2 6280 6476

OFFICES - OVERSEAS

WATERCO (EUROPE) LIMITED
Sittingbourne, Kent, UK
Tel: +44 (0) 1795 521 733

WATERCO FRANCE
Saint Priest, France
Tel: +33 4 72 79 33 30

WATERCO (USA) INC
Augusta, Georgia, USA
Tel: +1 706 793 7291

WATERCO CANADA
Longueuil, Quebec, Canada
Tel: +1 450 748 1421

WATERCO (NZ) LIMITED
Auckland, New Zealand
Tel: +64 9 525 7570

WATERCO © LIMITED
Guangzhou, China
Tel: +86 20 3222 2180

WATERCO (FAR EAST) SDN BHD
Selangor, Malaysia
Tel: +60 3 6145 6000

PT WATERCO INDONESIA
Jakarta, Indonesia
Tel: +62 21 4585 1481

WATERCO SINGAPORE INTL PTE LTD
Nehsons Building, Singapore
Tel: +65 6344 2378

WATERCO

Waterco Limited ABN 62 002 070 733

