



# HAYWARD®

## ***FULL INVERTER***

**POMPE A CHALEUR POUR PISCINE**  
**SWIMMING POOL HEAT PUMP UNIT**  
**UNIDAD DE BOMBA DE CALOR PARA PISCINAS**  
**BOMBA DE AQUECIMENTO PARA PISCINAS**  
**HEIZPUMPENANLAGE FÜR EIN SCHWIMMBECKEN**  
**ZWEMBAD WARMTEPOMP**  
**UNITÀ DI RISCALDAMENTO A POMPA DI CALORE PER PISCINE**  
**VARMEPUMPE TIL SVØMMEBASSENG**  
**ТЕПЛОВОЙ НАСОС ДЛЯ ПЛАВАТЕЛЬНОГО БАССЕЙНА**



HP5091DT3HA	HP5111DT3HA	HP5151DT3HA	HP5181DT3HA
-------------	-------------	-------------	-------------

**Manuel d'instructions et d'installation**  
**Installation & Instruction Manual**  
**Manual de Instalación e Instrucciones**  
**Manual de instalação e de instruções**  
**Einbau- & Anleitungshandbuch**  
**Installatie- en bedieningshandleiding**  
**Manuale d'Uso e di Installazione**  
**Installerings- og brukerveiledning**  
**Руководство по монтажу и эксплуатации**





# **HAYWARD<sup>®</sup>**

## ***FULL INVERTER***

**POMPE A CHALEUR POUR PISCINE**



HP5091DT3HA	HP5111DT3HA	HP5151DT3HA	HP5181DT3HA
-------------	-------------	-------------	-------------

**Manuel d'instructions et d'installation**

# SOMMAIRE

<b>1. CONSIGNES GÉNÉRALES - SÉCURITÉ</b>	<b>1</b>
<b>2. CARACTÉRISTIQUES TECHNIQUES</b>	<b>5</b>
2.1 Données techniques de la pompe à chaleur	5
2.2 Plage de fonctionnement	6
2.3 Dimensions	7
<b>3. INSTALLATION ET RACCORDEMENT</b>	<b>8</b>
3.1 Schéma de principe	8
3.2 Pompe à chaleur	8
3.3 Raccordement hydraulique	10
3.4 Raccordement électrique	11
3.5 Premier démarrage	12
3.6 Réglage du débit d'eau	14
<b>4. INTERFACE UTILISATEUR</b>	<b>15</b>
4.1 Présentation générale	15
4.2 Réglage Date et Heure	17
4.3 Réglage des Timers Marche/Arrêt	18
4.4 Réglage du point de consigne	20
4.5 Verrouillage et déverrouillage de l'écran tactile	21
4.6 Activation et réglage du mode SILENCE	22
<b>5. ENTRETIEN ET HIVERNAGE</b>	<b>25</b>
5.1 Entretien	25
5.2 Hivernage	25
<b>6. ANNEXES</b>	<b>26</b>
6.1 Schémas électriques	26
6.2 Raccordements priorité chauffage Pompe Monophasé	28
6.3 Vues éclatées et pièces détachées	30
6.4 Guide de dépannage	34
6.5 Garantie	37
6.6 Fin de vie de l'appareil	37

À lire attentivement et à conserver pour une consultation ultérieure.

Ce document doit être remis au propriétaire de la piscine et doit être conservé par celui-ci en lieu sûr.

# 1. CONSIGNES GÉNÉRALES - SÉCURITÉ

---

Nous vous remercions d'avoir acheté cette pompe à chaleur de piscine Hayward. La pompe à chaleur Hayward FULL INVERTER a été conçue selon des normes strictes de fabrication pour satisfaire les plus hauts niveaux de qualité requis.

Les pompes à chaleur Hayward vont vous offrir d'exceptionnelles performances tout au long de votre saison de baignade en adaptant la puissance, la consommation électrique et le niveau sonore au besoin de chauffage de votre piscine grâce à la logique de contrôle FULL INVERTER.



***Lisez attentivement les consignes de ce manuel avant d'utiliser l'appareil.***

Le présent manuel inclut toutes les informations nécessaires concernant l'installation, l'élimination des dysfonctionnements et l'entretien.

Lisez attentivement ce manuel avant d'ouvrir l'unité, ou de réaliser des opérations d'entretien sur celle-ci. Le fabricant de ce produit ne sera en aucun cas tenu responsable en cas de blessure d'un utilisateur ou d'un endommagement de l'unité suite à d'éventuelles erreurs lors de l'installation, de l'élimination des dysfonctionnements, ou d'un entretien inutile. Il est primordial de suivre à tout moment les instructions spécifiées dans ce manuel.

Après avoir lu ce manuel, rangez le en vue d'une utilisation ultérieure.

## **Personnel habilité**

- L'installation, les raccordements électriques, l'entretien et les réparations de l'appareil doivent être effectués par un professionnel agréé conformément aux textes réglementaires et règles de l'art en vigueur dans le pays où l'appareil est installé (cf § 3.4). Pour toute intervention sur le circuit frigorifique, le professionnel doit être titulaire d'une attestation de capacité à la manipulation des fluides frigorigènes.  
Pour la France :
  - Installation électrique basse tension selon la NF-C 15-100.
  - Législation sur le maniement des fluides frigorigènes : Décret 2007/737 et ses arrêtés d'application.

# 1. CONSIGNES GÉNÉRALES - SÉCURITÉ (suite)

## Ce produit contient du gaz réfrigérant R32



*Cet appareil contient du R32.*

*Ne jamais utiliser un réfrigérant autre que du R32. Tout autre corps gazeux mélangé avec le R32 risque de provoquer des pressions anormalement élevées pouvant conduire à une panne ou à une rupture de tuyaux et blesser des personnes.*

*Lors de réparations ou d'opérations de maintenance utiliser des tubes de cuivre conformes à la Norme NF EN 12735-1 et à la Directive Européenne des équipements sous pression 97/23/CE.*

*La pompe à chaleur étant sous pression ne jamais percer les tuyaux ni tenter de faire une brasure. Il y a risque d'explosion.*

*Ne jamais exposer l'appareil à des flammes, des étincelles ou autre sources d'allumage. Il pourrait exploser et entraîner des blessures graves voire mortelles.*

*Pour la détection de fuites de fluide frigorigène : ne pas utiliser de lampe haloïde ni tout autre détecteur utilisant une flamme nue. En aucune circonstance des sources potentielles d'inflammation ne doivent être utilisées.*

Ce produit contient des gaz à effet de serre fluorés encadrés par le protocole de Kyoto. Ne libérez pas ces gaz dans l'atmosphère.

Valeur GWP(1) : 675, Valeur basée sur le 4ème rapport du GIEC.

Groupe de sécurité : A2L.

La quantité de réfrigérant basée sur la réglementation F Gaz 517/2014 est indiquée sur la plaque signalétique de l'unité.

Toute intervention sur le circuit frigorifique doit être effectuée par un professionnel agréé comme précisé précédemment.

Des inspections périodiques de fuite de réfrigérant peuvent être exigées en fonction de la législation européenne ou locale. Veuillez contacter votre distributeur local pour plus d'informations.

- Attention, les fluides frigorigènes peuvent être inodores.
- Ne pas percer ou chauffer la tuyauterie, risque d'explosion et de graves brûlures.
- Ne pas utiliser de moyen d'accélération du processus de dégivrage ou de nettoyage autre que ceux recommandés par le fabricant.
- L'appareil doit être stocké dans un local ne contenant pas de sources d'inflammation fonctionnant en permanence (par exemple : feux nus, appareil à gaz ou radiateur électrique en fonctionnement).

(1) Potentiel de réchauffement global

# 1. CONSIGNES GÉNÉRALES - SÉCURITÉ (suite)

## Conditions d'installation

- Cette pompe à chaleur est exclusivement destinée à chauffer l'eau de piscine, ne pas utiliser ce matériel à d'autres fins.
- N'essayez pas d'installer vous-même cet appareil.
- Si vous détectez tout défaut ou situation anormale, n'installez pas la pompe à chaleur et contactez immédiatement votre revendeur.
- En cas de stockage la pompe à chaleur doit être stockée dans une pièce bien ventilée et d'une surface au sol de plus de  $A_{\min}$  (m<sup>2</sup>) donnée par la formule suivante :  $A_{\min} = (M/(2.5 \times 0.22759 \times h_0))^2$   
M est la charge de réfrigérant dans l'appareil en kg et h<sub>0</sub> est la hauteur de stockage. Pour un stockage au sol h<sub>0</sub> = 0,6 m.
- Ce produit a été exclusivement conçu pour un usage domestique et une installation en extérieur. L'air qui s'échappe du produit doit pouvoir s'écouler librement et ne doit pas être utilisé à d'autres fins comme le chauffage ou le refroidissement d'une pièce ou d'un bâtiment.
- Vérifier le câble d'alimentation. Si le câble d'alimentation est endommagé, il doit être remplacé par le fabricant, son service après vente ou par une personne qualifiée et habilitée.
- Le raccordement de l'appareil à la terre et sa continuité sont obligatoires. Le fil de terre doit être plus long que les autres fils pour prévenir des risques d'électrisation en cas d'arrachement du câble. L'installation électrique doit obligatoirement être équipée d'une protection différentielle de 30 mA (cf § 3.4).
- Vérifier que le support prévu pour l'unité est convenablement dimensionné pour le poids de l'appareil.
- **Toute recommandation non suivie annule la garantie.**

## Consignes pour l'entretien - maintenance

Les opérations de maintenance doivent être réalisées 1 fois par an afin de garantir la longévité et le bon fonctionnement de la pompe à chaleur.

- L'entretien et les différentes opérations doivent être réalisés à la fréquence et aux moments recommandés, tel que spécifié dans le présent manuel.
- N'utilisez que des pièces détachées d'origine.
- Vérifier le câble d'alimentation. Si le câble d'alimentation est endommagé, il doit être remplacé par le fabricant, son service après vente ou par une personne qualifiée et habilitée.
- Vérifier le raccordement de l'appareil à la terre et sa continuité.
- Nettoyer l'évaporateur à l'aide d'une brosse souple ou d'un jet d'air ou d'eau.  
**Attention ne jamais utiliser un nettoyeur haute pression.**

# 1. CONSIGNES GÉNÉRALES - SÉCURITÉ (suite)

- Vérifier le bon écoulement des condensats.
- Vérifier le serrage des raccords hydrauliques et électriques.
- Vérifier l'étanchéité hydraulique du condenseur.
- Faire vérifier l'étanchéité du circuit frigorifique au détecteur de fuite **par un professionnel agréé.**



***Avant toute opération de maintenance la pompe à chaleur doit être déconnectée de toute source de courant électrique. Les opérations de maintenance doivent être réalisées uniquement par un personnel qualifié et habilité à manipuler les fluides frigorigènes.***

## Consignes pour l'hivernage

- Mettre la pompe à chaleur en Mode "OFF".
- Couper l'alimentation de la pompe à chaleur.
- Vider le condenseur à l'aide de la vidange pour éviter tout risque de dégradation (risque important de gel).
- Fermer la vanne "by-pass" et dévisser les raccords unions entrée/sortie.
- Chasser au maximum l'eau stagnante résiduelle du condenseur à l'aide d'un pistolet à air.
- Obturer l'entrée et la sortie d'eau sur la pompe à chaleur pour éviter l'intrusion de corps étranger.
- Couvrir la pompe à chaleur avec la housse d'hivernage prévue à cet effet.



***Tout dommage occasionné par un mauvais hivernage entraîne l'annulation de la garantie.***

## Conditions d'utilisation

Cet appareil peut être utilisé par des enfants âgés d'au moins 8 ans ainsi que par des personnes ayant des capacités physiques, sensorielles ou mentales réduites, ou dénuées d'expérience ou de connaissance, s'ils sont correctement surveillés ou si des instructions relatives à l'utilisation de l'appareil en toute sécurité leur ont été données et si les risques encourus ont été appréhendés.

Les enfants ne doivent pas jouer avec l'appareil.

Le nettoyage et l'entretien par l'utilisateur ne doivent pas être effectués par des enfants sans surveillance.



## 2. CARACTÉRISTIQUES TECHNIQUES

### 2.1 Données techniques de la pompe à chaleur

Modèles	FULL INVERTER	HP5091DT3HA	HP5111DT3HA	HP5151DT3HA	HP5181DT3HA
Tension d'alimentation	V	220V-240V~ / 1ph / 50Hz			
Réfrigérant	/	R32			
Charge	kg	0,430	0,450	0,60	0,670
Masse en teqCO <sub>2</sub>	/	0,29	0,30	0,41	0,45
Fréquence du contrôle de fuite	/	Aucune exigence mais conseillé de façon annuelle			
Capacité de chauffage Min--Max <sup>(a)</sup>	kW	2,46 -- 9,17	2,36 -- 11,45	3,31 -- 15,90	3,2 -- 18,15
Puissance électrique absorbée Min--Max <sup>(a)</sup>	kW	0,17 -- 1,45	0,17 -- 1,80	0,27 -- 2,84	0,22 -- 3,13
Courant nominal de service Min--Max <sup>(a)</sup>	A	1,17 -- 6,42	1,19 -- 7,85	1,37 -- 12,35	1,45 -- 13,58
COP Max--Min <sup>(a)</sup>	/	14,37 -- 6,32	13,88 -- 6,35	12,26 -- 5,59	14,34 -- 5,80
Capacité de chauffage Min--Max <sup>(b)</sup>	kW	1,75 -- 7,05	1,56 -- 8,00	3,05 -- 12,40	2,86 -- 14,11
Puissance électrique absorbée Min--Max <sup>(b)</sup>	kW	0,27 -- 1,51	0,279 -- 1,74	0,42 -- 2,65	0,43 -- 2,99
COP Max--Min <sup>(b)</sup>	/	6,40 -- 4,65	5,60 -- 4,80	7,26 -- 4,68	6,63 -- 4,71
Courant maximum de service (CMS)	A	8,40	9,50	14	15,9
Calibre du fusible	aM	10	12	16	20
Disjoncteur courbe D	D	10	12	16	20
Courant de démarrage	A	< CMS			
Raccordement hydraulique	mm	50 mm			
Débit d'eau nominal <sup>(a)</sup>	m <sup>3</sup> /h	4,00	5,00	6,70	7,70
Perte de charge sur l'eau max	kPa	3,80	4,0	6,3	10
Compresseur	/	DC Inverter Panasonic		DC Inverter Mitsubishi	
Type	/	Double Rotatif		Double Rotatif	
Quantité	/	1		1	
Résistance d'enroulement à 20°C	Ohm	1,208		0,95	
Ventilateur	/	Axial			
Quantité		1			
Diamètre	mm	405		510	
Nombre de pale	/	3			
Moteur	/	DC Inverter			
Quantité	/	1			
Vitesse de rotation	Tr/min	400 -- 700	500 -- 850	300 -- 750	400 -- 750
Vitesse Mode Silence	Tr/min	400	500	300	400
Niveau de pression acoustique à 1 m	dB(A)	50,2	53,9	50,8	54,0
Niveau de pression acoustique à 10 m	dB(A)	32,8	34,2	33,8	37,25
Dimensions nettes de l'unité (L-I-H)	mm	1003 / 418 / 605		1048 / 437 / 768	1161 / 473 / 862
Poids	kg	44	45	66	70

(a) Air sec 27°C - Humidité relative 78% - Température d'entrée d'eau 26°C.



(b) Air sec 15°C - Humidité relative 71% - Température d'entrée d'eau 26°C

## 2. CARACTÉRISTIQUES TECHNIQUES (suite)

---

### 2.2 Plage de fonctionnement

Utiliser la pompe à chaleur dans les plages suivantes de températures et d'humidité pour assurer un fonctionnement sûr et efficace.

	Mode chauffage 	Mode Refroidissement 
Température extérieure	-7°C – +35°C	+7°C – +43°C
Température d'eau	+12°C – +32°C	+8°C – +40°C
Humidité relative	< 80%	< 80%
Plage de réglage point de consigne	+15°C – +32°C	+8°C – +32°C



***Si la température ou l'humidité ne correspond pas à ces conditions, des dispositifs de sécurité peuvent se déclencher et la pompe à chaleur peut ne plus fonctionner.***



***La température maximum de chauffage est limitée à +32° Celsius afin d'éviter la détérioration des liners. Hayward décline toutes responsabilités dans le cas d'une utilisation au delà des +32°C.***

## 2. CARACTERISTIQUES TECHNIQUES (suite)

### 2.3 Dimensions

Modèles :

HP5091DT3HA / HP5111DT3HA / HP5151DT3HA / HP5181DT3HA

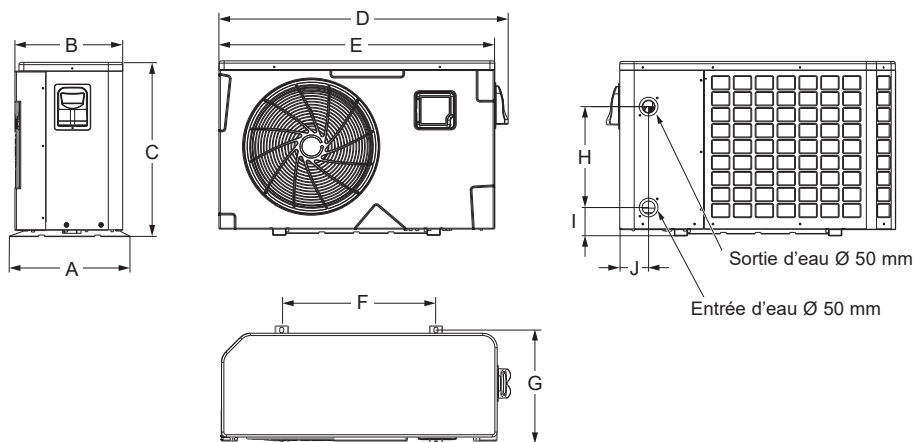

Unité : mm

Repère \ Modèle	HP5091DT3HA / HP5111DT3HA	HP5151DT3HA	HP5181DT3HA
<b>A</b>	418	436,5	473
<b>B</b>	374	418	451,5
<b>C</b>	604,5	767,5	862
<b>D</b>	1003	1047,5	1160,5
<b>E</b>	956	1002	1115
<b>F</b>	535	615	790
<b>G</b>	394,5	410	447
<b>H</b>	350	350	466
<b>I</b>	97,7	101,2	97,6
<b>J</b>	99,2	106,5	113,5

## 3. INSTALLATION ET RACCORDEMENT

### 3.1 Schéma de principe

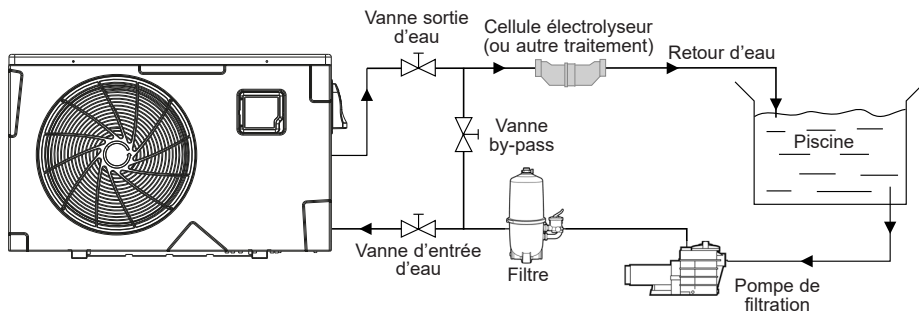

Note : La pompe à chaleur est fournie sans aucun équipement de traitement ou de filtration. Les éléments présentés sur le schéma sont des pièces à fournir par l'installateur.

### 3.2 Pompe à chaleur



**Placer la pompe à chaleur à l'extérieur et en dehors de tout local technique fermé.**

**Choisir un emplacement de préférence ensoleillé et à l'abri des vents dominants.**

**L'appareil doit être parfaitement accessible pour les travaux d'installation et de maintenance ultérieurs.**

**Placée sous abri, les distances minimum prescrites ci-dessous doivent être respectées afin d'éviter tout risque de recirculation d'air et une dégradation des performances globales de la pompe à chaleur.**

Unité : mm

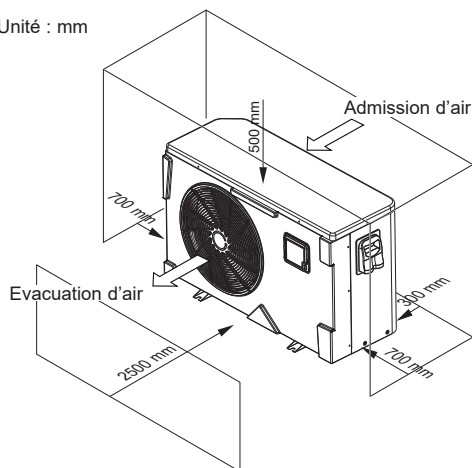

### 3. INSTALLATION ET RACCORDEMENT (suite)



**Ne pas poser l'appareil directement au sol car cela peut être cause de troubles.**

**La position au sol sur des plots anti-vibrations est à privilégier.**

**Un support mural ne doit pas être utilisé dans des conditions susceptibles de transmettre des vibrations.**

**Ne pas installer la pompe à chaleur sur un support risquant d'amplifier les vibrations de l'unité.**

**Ne pas installer la pompe à chaleur dans un endroit susceptible d'amplifier son niveau sonore ou dans un endroit où le bruit de l'unité risquerait de gêner le voisinage.**

**Ne pas utiliser d'adhésifs : ceux-ci ne sont pas considérés comme des moyens de fixation fiables.**

**Installer de préférence la pompe à chaleur sur une dalle béton plane et désolidarisée.**

**Monter la pompe à chaleur sur les silentblochs fournis (visserie et rondelles fournies).**

**Fixer l'appareil en respectant le serrage indiqué pour éviter tout risque d'accident ou dommage pour les matériels et les personnes.**

**Autre possibilité : installer la pompe à chaleur sur des supports sol en caoutchouc en utilisant la visserie adaptée (non fournie).**

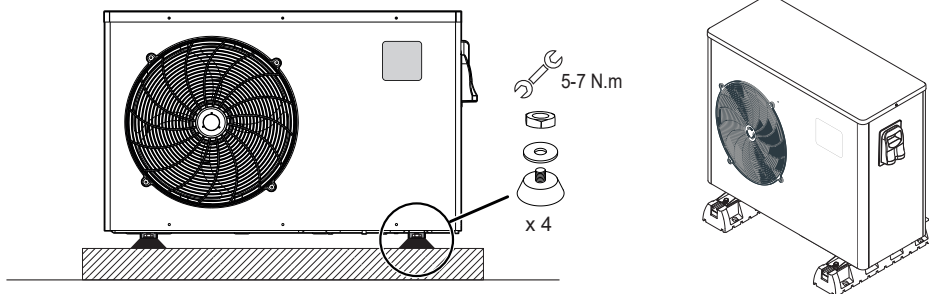

**Distance maximale d'installation entre la pompe à chaleur et la piscine 15 mètres.**

**Longueur totale aller-retour des canalisations hydrauliques 30 mètres.**

**Isoler les canalisations hydrauliques de surface et enterrées.**

**La pompe à chaleur doit être installée à une distance minimum du bassin conformément à la NF C 15-100 (soit à 3,5 m du plan d'eau pour la France) ou conformément aux normes d'installation en vigueur dans les autres pays.**

**Ne pas installer la pompe à chaleur à proximité d'une source de chaleur.**

**En cas d'installation dans des régions neigeuses il est conseillé d'abriter la machine afin d'éviter une accumulation de neige sur l'évaporateur.**

## 3. INSTALLATION ET RACCORDEMENT (suite)

---

### 3.3 Raccordement hydraulique

La pompe à chaleur est fournie avec deux raccords union Ø 50 mm. Utiliser du tube PVC pour canalisation hydraulique Ø 50 mm. Raccorder l'entrée d'eau de la pompe à chaleur à la conduite venant du groupe de filtration puis raccorder la sortie d'eau de la pompe à chaleur à la conduite d'eau allant au bassin (cf schéma ci-dessous).

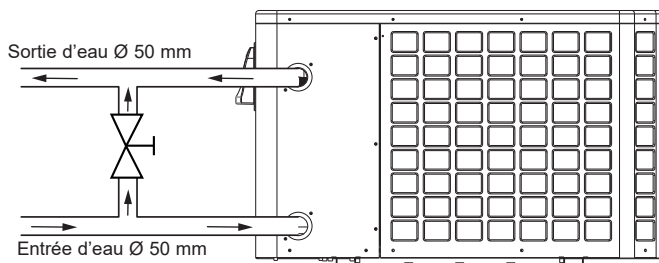

Installer une vanne dite "by-pass" entre l'entrée et la sortie de la pompe à chaleur.



***Si un distributeur automatique ou un électrolyseur est utilisé, il doit impérativement être installé après la pompe à chaleur dans le but de protéger le condenseur Titane contre une concentration trop importante de produit chimique.***



***Veillez à bien installer la vanne by-pass et les raccords union fournis au niveau de l'entrée et de la sortie d'eau de l'unité, afin de simplifier la purge durant la période hivernale, d'en faciliter l'accès ou son démontage pour l'entretien.***

### 3. INSTALLATION ET RACCORDEMENT (suite)

#### 3.4 Raccordement électrique



**L'installation électrique et le câblage de cet équipement doivent être conformes aux règles d'installation locales en vigueur.**

F	NF C15-100	GB	BS7671:1992
D	DIN VDE 0100-702	EW	EVHS-HD 384-7-702
A	ÖVE 8001-4-702	H	MSZ 2364-702/1994/MSZ 10-553 1/1990
E	UNE 20460-7-702 1993, RECBT ITC-BT-31 2002	M	MSA HD 384-7-702.S2
IRL	Wiring Rules + IS HD 384-7-702	PL	PN-IEC 60364-7-702:1999
I	CEI 64-8/7	CZ	CSN 33 2000 7-702
LUX	384-7.702 S2	SK	STN 33 2000-7-702
NL	NEN 1010-7-702	SLO	SIST HD 384-7-702.S2
P	RSIUEE	TR	TS IEC 60364-7-702



**Vérifiez que l'alimentation électrique disponible et la fréquence du réseau correspondent au courant de fonctionnement requis, en prenant en considération l'emplacement spécifique de l'appareil, et le courant nécessaire pour alimenter tout autre appareil connecté au même circuit.**

**HP5091DT3HA / HP5111DT3HA / HP5151DT3HA / HP5181DT3HA  
230V $\sim$  +/- 10 % 50 Hz 1 Phase**

**Observez le schéma de câblage correspondant en annexe.  
Le boîtier de raccordement se trouve du côté droit de l'unité. Trois connexions sont destinées à l'alimentation électrique, et deux à la commande de la pompe de filtration (Asservissement).**

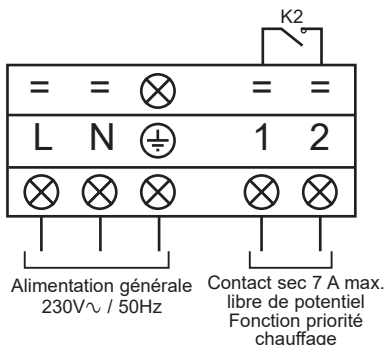

### 3. INSTALLATION ET RACCORDEMENT (suite)

---



**Ne jamais utiliser de prise de courant pour l'alimentation.**  
**La ligne d'alimentation électrique doit être dotée, de manière appropriée, d'un dispositif de protection omnipolaire de type disjoncteur courbe D ainsi que d'un disjoncteur différentiel de protection 30 mA (voir tableau après).**

Modèles		HP5091DT3HA	HP5111DT3HA	HP5151DT3HA	HP5181DT3HA
Alimentation électrique	V/Ph/Hz	230V~ 50Hz	230V~ 50Hz	230V~ 50Hz	230V~ 50Hz
Disjoncteur courbe D	A	8 D	10 D	16 D	20 D
Section de câble	mm <sup>2</sup>	3G 2,5	3G 2,5	3G 2,5	3G 4



**Utiliser un câble d'alimentation Type RO2V/R2V ou équivalent.**



**Les sections de câble sont données pour une longueur maximum de 25 m, elles doivent néanmoins être vérifiées et adaptées en fonction des conditions d'installation.**



**Prenez toujours garde d'arrêter l'alimentation principale avant d'ouvrir la boîte de commande électrique.**  
**Après sectionnement de l'alimentation, attendre 10 minutes avant d'accéder aux parties actives internes de l'équipement (énergie stockée dans les condensateurs).**

#### 3.5 Premier démarrage

Procédure de démarrage - une fois l'installation terminée, suivez et respectez les étapes suivantes :

- 1) Faites pivoter les ventilateurs à la main afin de vérifier qu'il peut tourner librement, et que l'hélice est fixée correctement sur l'arbre du moteur.
- 2) Assurez-vous que l'unité est connectée correctement à l'alimentation principale (voir le schéma de câblage en annexe).
- 3) Activez la pompe de filtration.
- 4) Vérifiez que toutes les vannes d'eau sont ouvertes, et que l'eau s'écoule vers l'unité avant de passer en mode chauffage ou refroidissement.
- 5) Vérifiez que le tuyau de purge des condensats est fixé correctement, et ne présente aucune obstruction.
- 6) Activez l'alimentation électrique destinée à l'unité, puis appuyez sur le bouton Marche/Arrêt  sur le panneau de commande.



### 3. INSTALLATION ET RACCORDEMENT (suite)

---

- 7) Assurez-vous que les symboles d'alarme ou de verrouillage ne s'affichent pas. Le cas échéant voir le guide de dépannage (voir § 6.4).
- 8) Fixez le débit d'eau à l'aide de la vanne by-pass (voir § 3.6 et 2.1), tel que prévu respectivement pour chaque modèle, de manière à obtenir une différence de température Entrée/Sortie de 2°C.
- 9) Après un fonctionnement de quelques minutes, vérifiez que l'air sortant de l'unité s'est refroidi (entre 5 et 10°).
- 10) L'unité étant en service, désactivez la pompe de filtration. L'unité doit s'arrêter automatiquement et afficher le code d'erreur E03 (voir § 6.4).
- 11) Faites fonctionner l'unité et la pompe de la piscine 24 heures sur 24, jusqu'à ce que la température de l'eau souhaitée soit atteinte. Quand la température d'entrée d'eau atteint la valeur de consigne, l'unité s'arrête. Elle redémarre alors automatiquement (tant que la pompe de la piscine est en service) si la température de la piscine est inférieure d'au moins 0.5°C à la température de consigne.

**Contrôleur de débit** - L'unité est dotée d'un contrôleur de débit qui active la pompe à chaleur lorsque la pompe de filtration de la piscine est en service, et la désactive lorsque la pompe de la filtration est hors service. Par manque d'eau, le code d'alarme E03 s'affiche sur le régulateur (Voir § 6.4).

**Temporisation** - l'unité intègre une temporisation de 3 minutes, afin de protéger les composants du circuit de commande, d'éliminer toute instabilité en terme de redémarrage et, toute interférence au niveau du contacteur. Grâce à cette temporisation, l'unité redémarre automatiquement 3 minutes environ après toute coupure du circuit de commande. Même une coupure de courant de courte durée active la temporisation de démarrage.

### 3. INSTALLATION ET RACCORDEMENT (suite)

---

#### 3.6 Réglage du débit d'eau

Les vannes d'entrée et de sortie d'eau étant ouvertes, ajuster la vanne dite "by-pass" de façon à obtenir une différence de 2°C entre la température d'entrée et de sortie d'eau (voir schéma de principe § 3.1).

Vous pouvez vérifier le réglage en visualisant les températures entrée/sortie directement sur le panneau de commande.



Note : L'ouverture de la vanne dite "by-pass" engendre un débit moins important d'ou une augmentation du  $\Delta T$ .

La fermeture de la vanne dite "by-pass" engendre un débit plus important d'ou une diminution du  $\Delta T$ .

## 4. INTERFACE UTILISATEUR

### 4.1 Présentation générale

La pompe à chaleur est équipée d'un panneau de commande digital à écran tactile, raccordé électriquement et pré-réglé en usine en mode chauffage.

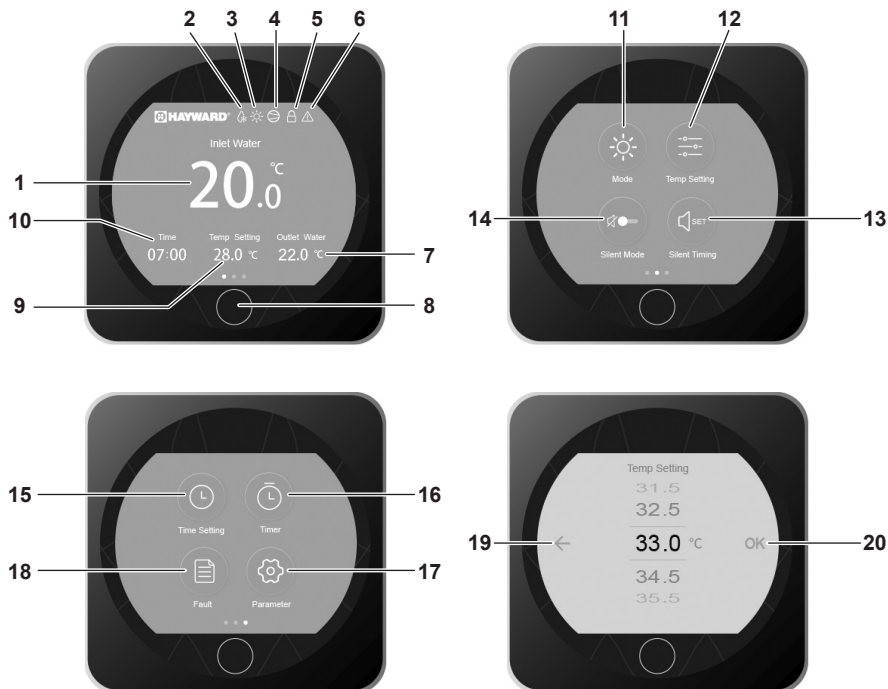

### Légende

1	Température d'entrée d'eau
2	Dégivrage en cours
3	Mode de fonctionnement
4	Témoin de marche du compresseur
5	Verrouillage de l'écran
6	Alarme
7	Température de sortie d'eau
8	Marche/Arrêt/Retour
9	Température de consigne
10	Heure

11	Sélection du mode de fonctionnement
12	Réglage du point de consigne
13	Réglage Timer mode silence
14	Activation du mode silence
15	Réglage date et heure
16	Réglage Timers Marche/Arrêt
17	Accès paramètres avancés
18	Retour (sans défauts)
19	Retour (sans validation)
20	Validation

## 4. INTERFACE UTILISATEUR (suite)

### Mode OFF/ARRÊT

Lorsque la pompe à chaleur est à l'arrêt (en veille), l'inscription OFF apparaît sur l'écran.

L'écran noir indique que la pompe à chaleur est à l'arrêt. Le réglage des paramètres est possible dans ce mode.



### Mode ON/MARCHE

Lorsque la pompe à chaleur est en fonctionnement ou en régulation (atteinte du point de consigne) l'écran devient bleu.



Pour passer du mode OFF au mode ON et inversement appuyer sur le bouton .

## 4. INTERFACE UTILISATEUR (suite)

### 4.2 Réglage Date et Heure

Le réglage de la date et de l'heure peut se faire indifféremment en mode ON ou OFF.

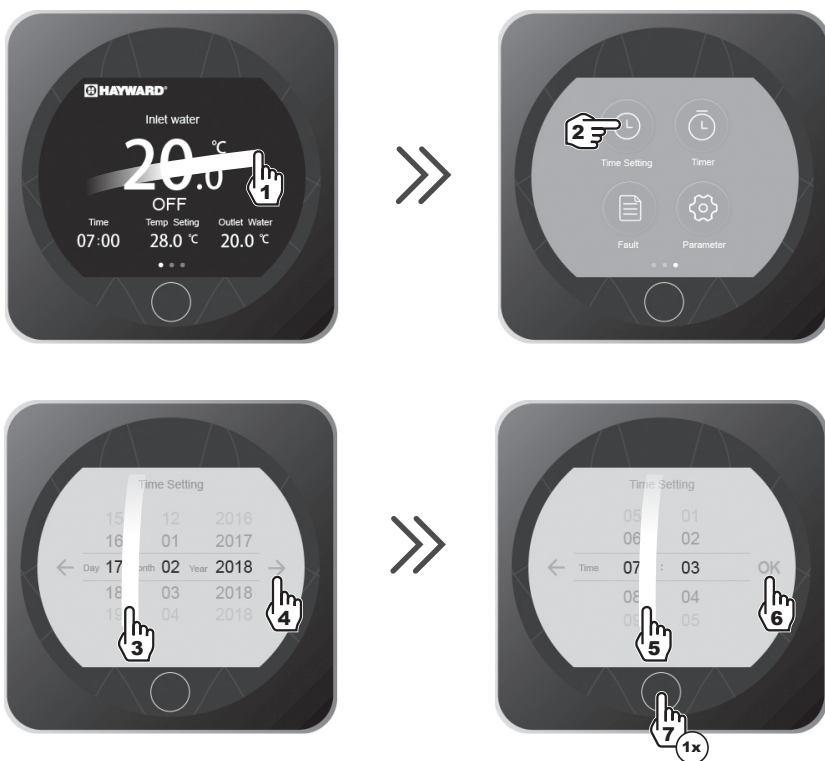

- Presser 1 fois sur  pour revenir à l'écran principal.

## 4. INTERFACE UTILISATEUR (suite)

### 4.3 Réglage des Timers Marche/Arrêt

Le réglage de cette fonction est nécessaire dès lors que vous souhaitez faire fonctionner votre pompe à chaleur sur une plus courte période que celle définie par l'horloge de filtration. Ainsi vous pourrez programmer un départ différé et un arrêt anticipé ou simplement interdire une plage horaire de fonctionnement (par exemple la nuit).

Vous avez la possibilité de programmer un Timer Départ et un Timer Arrêt. Le pas de réglage est "d'heure en heure".



## 4. INTERFACE UTILISATEUR (suite)

---



**Surbrillance bleue = Activé**  
**Grisé = Désactivé**

- Presser 2 fois sur  pour revenir à l'écran principal.

## 4. INTERFACE UTILISATEUR (suite)

### 4.4 Réglage du point de consigne

Le réglage du point de consigne s'effectue indifféremment en mode ON ou en mode OFF avec une précision de 0,5°C.



- Presser 1 fois sur  pour revenir à l'écran principal.



**Il est recommandé de ne jamais dépasser la température de 30°C pour éviter l'altération des liners.**



## 4. INTERFACE UTILISATEUR (suite)

### 4.5 Verrouillage et déverrouillage de l'écran tactile

Le verrouillage et déverrouillage de l'écran peut se faire indifféremment en mode ON ou en mode OFF.



Verrouillage activé



Verrouillage désactivé

## 4. INTERFACE UTILISATEUR (suite)

### 4.6 Activation et réglage du mode SILENCE

Le mode silence permet une utilisation de la pompe à chaleur en mode économique et très silencieux lorsque les besoins de chauffage sont faibles (maintien en température du bassin, ou besoin d'avoir un fonctionnement ultra silencieux).

Cette fonction peut être Activée/Désactivée manuellement, ou à l'aide d'un Timer.

#### Activation / Désactivation



Mode silence désactivé



Mode silence activé



- Presser 1 fois sur  pour revenir à l'écran principal.

## 4. INTERFACE UTILISATEUR (suite)

---

### Réglage du Timer du mode silence



## 4. INTERFACE UTILISATEUR (suite)

---



- Presser 2 fois sur  pour revenir à l'écran principal.



**Le pas de réglage est "d'heure en heure".  
Une fois le Timer activé, celui-ci est actif 7 jours sur 7.**

## 5. ENTRETIEN ET HIVERNAGE

---

### 5.1 Entretien

Ces opérations de maintenance doivent être réalisées 1 fois par an afin de garantir la longévité et le bon fonctionnement de la pompe à chaleur.

- L'entretien et les réparations de l'appareil doivent être effectués par un professionnel agréé conformément aux textes réglementaires et règles de l'art en vigueur dans le pays où l'appareil est installé (cf § 3.4). Pour toute intervention sur le circuit frigorifique, le professionnel doit être titulaire d'une attestation de capacité à la manipulation des fluides frigorigènes.
- Vérifier le câble d'alimentation. Si le câble d'alimentation est endommagé, il doit être remplacé par le fabricant, son service après vente ou par une personne qualifiée et habilitée.
- Vérifier le raccordement de l'appareil à la terre et sa continuité.
- Nettoyer l'évaporateur à l'aide d'une brosse souple ou d'un jet d'air ou d'eau. **Attention ne jamais utiliser un nettoyeur haute pression.**
- Vérifier le bon écoulement des condensats.
- Vérifier le serrage des raccords hydrauliques et électriques
- Vérifier l'étanchéité hydraulique du condenseur.
- Faire vérifier l'étanchéité du circuit frigorifique au détecteur de fuite **par un professionnel agréé.**



***Avant toute opération de maintenance la pompe à chaleur doit être déconnectée de toute source de courant électrique. Les opérations de maintenance doivent être réalisées uniquement par un personnel qualifié et habilité à manipuler les fluides frigorigènes.***

### 5.2 Hivernage

- Mettre la pompe à chaleur en Mode "OFF".
- Couper l'alimentation de la pompe à chaleur.
- Vider le condenseur à l'aide de la vidange pour éviter tout risque de dégradation (risque important de gel).
- Fermer la vanne "by-pass" et dévisser les raccords unions entrée/sortie.
- Chasser au maximum l'eau stagnante résiduelle du condenseur à l'aide d'un pistolet à air.
- Obturer l'entrée et la sortie d'eau sur la pompe à chaleur pour éviter l'intrusion de corps étranger.
- Couvrir la pompe à chaleur avec la housse d'hivernage prévue à cet effet.



***Tout dommage occasionné par un mauvais hivernage entraîne l'annulation de la garantie.***

# 6. ANNEXES

## 6.1 Schémas électriques

### HP5091DT3HA / HP5111DT3HA

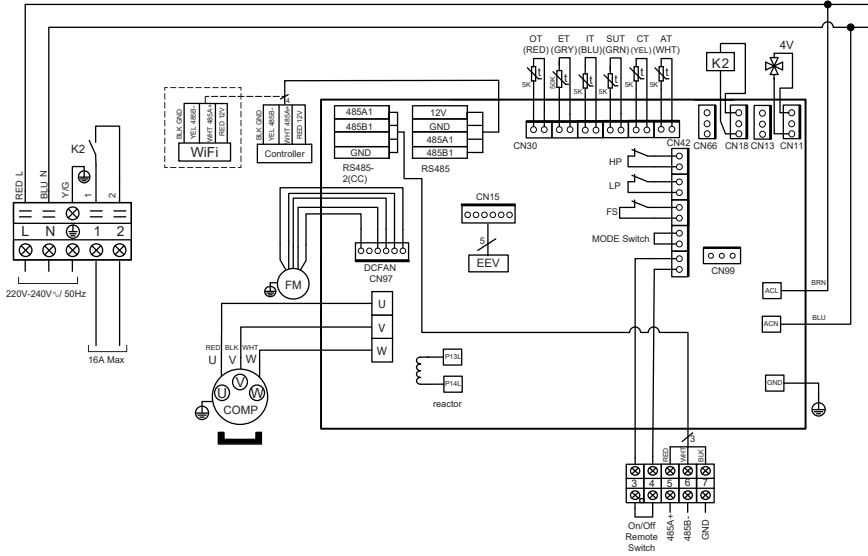

#### LEGENDE

- |   |  |
|---|--|
| <b>AT</b> : SONDE DE TEMPÉRATURE D'AIR        | <b>LP</b> : PRESSOSTAT BASSE PRESSION          |
| <b>COMP</b> : COMPRESSEUR                     | <b>OT</b> : SONDE DE TEMPÉRATURE SORTIE D'EAU  |
| <b>CT</b> : SONDE TEMPÉRATURE ÉVAPORATEUR     | <b>SUT</b> : SONDE DE TEMPÉRATURE D'ASPIRATION |
| <b>EEV</b> : DÉTENDEUR ÉLECTRONIQUE           | <b>4V</b> : VANNE 4 VOIES                      |
| <b>FM</b> : MOTEUR VENTILATEUR                | <b>K2</b> : CONTACT SEC MAX. 16 A              |
| <b>FS</b> : DÉTECTEUR PRÉSENCE D'EAU          | <b>ET</b> : SONDE TEMPÉRATURE REFOULEMENT      |
| <b>HP</b> : PRESSOSTAT HAUTE PRESSION         | ----- : OPTION                                 |
| <b>IT</b> : SONDE DE TEMPÉRATURE ENTRÉE D'EAU |  |







---

*Page laissée blanche intentionnellement*

## 6. ANNEXES (suite)

### 6.3 Vues éclatées et pièces détachées

HP5091DT3HA / HP5111DT3HA / HP5151DT3HA / HP5181DT3HA

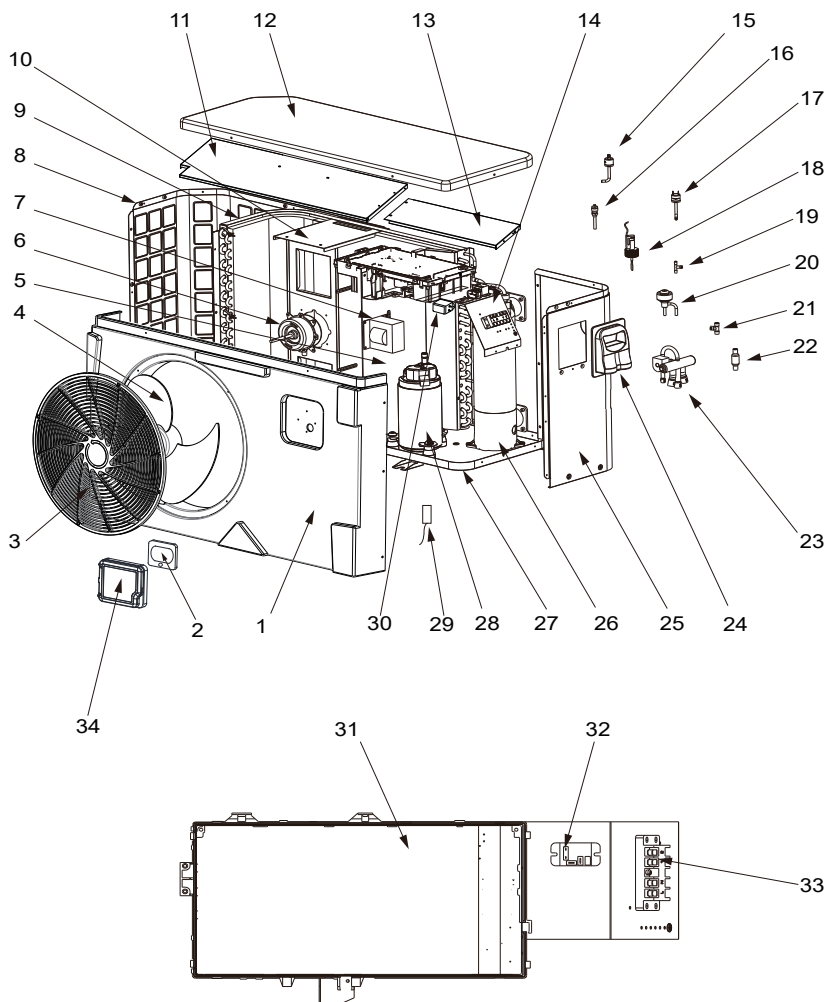

## 6. ANNEXES (suite)

Rep	Désignation	Réf.	HP5091DT3HA	HP5111DT3HA	HP5151DT3HA	HP5181DT3HA
1	Panneau Avant	HWX80900843	✓	✓	n/a	n/a
		HWX80900844	n/a	n/a	✓	n/a
		HWX80900850	n/a	n/a	n/a	✓
2	Régulateur LED	HWX72200070	✓	✓	✓	✓
3	Grille de protection ventilateur	HWX80900375	✓	✓	✓	n/a
		HWX20000220369	n/a	n/a	n/a	✓
		HWX301030000006	✓	✓	n/a	n/a
4	Hélice Ventilateur	HWX301030000001	n/a	n/a	✓	✓
		/	/	/	/	/
6	Moteur ventilateur DC	HWX80200018	✓	✓	n/a	n/a
		HWX20000330132	n/a	n/a	✓	✓
7	Bobine 16 A 50 Hz 5 mH	HWX82500020	✓	✓	n/a	n/a
	Bobine 20 A 50 Hz 5.2 mH	HWX82500021	n/a	n/a	✓	✓
8	Panneau Gauche	HWX80702123	✓	✓	n/a	n/a
		HWX80700244	n/a	n/a	✓	n/a
		HWX80702268	n/a	n/a	n/a	✓
9	Evaporateur à ailette	HWX80600042	✓	n/a	n/a	n/a
		HWX80600043	n/a	✓	n/a	n/a
		HWX80600044	n/a	n/a	✓	n/a
		HWX80600078	n/a	n/a	n/a	✓
10	Support Moteur	HWX80700218	✓	✓	n/a	n/a
		HWX80700248	n/a	n/a	✓	n/a
		HWX80700329	n/a	n/a	n/a	✓
11	/	/	/	/	/	/
12	Panneau supérieur	HWX80900055	✓	✓	n/a	n/a
		HWX301090200806	n/a	n/a	✓	n/a
		HWX80900076	n/a	n/a	n/a	✓
13	/	/	/	/	/	/
14	/	/	/	/	/	/
15	Pressostat basse pression NO 0.30 MPa / 0.15 MPa	HWX20000360157	✓	✓	✓	✓
16	Prise de pression 40 mm-1/2"	HWX20000140150	✓	✓	✓	✓
17	Pressostat haute pression NC 3.2 MPa/4.4 MPa	HWX20013605	✓	✓	✓	✓
18	Détecteur de débit d'eau	HWX83000068	✓	✓	✓	✓
19	Connecteur T Ø 6.5-2 x Ø 6.5(T) x 0.75	HWX20001460	✓	✓	✓	✓
20	Détendeur électronique	HWX81000011	✓	✓	n/a	n/a
		HWX81000013	n/a	n/a	✓	✓
21	Connecteur T Ø 9.52-2 x Ø 6.35(T) x 1.0	HWX304030000002	✓	✓	✓	✓
22	Filter Ø 9.7-Ø 9.7 (Ø19)	HWX20000140178	✓	✓	n/a	n/a
	Filter Ø 9.7-Ø 9.7 (Ø28)	HWX20041444	n/a	n/a	✓	✓
23	Vanne 4 voies	HWX20041437	✓	✓	✓	✓
24	Trappe d'accès électrique	HWX320922029	✓	✓	✓	✓
		HWX80700580	✓	✓	n/a	n/a
25	Panneau Droit	HWX80700878	n/a	n/a	✓	n/a
		HWX80700581	n/a	n/a	n/a	✓
		HWX72300013	✓	n/a	n/a	n/a
26	Condenseur Titane PVC	HWX72300014	n/a	✓	n/a	n/a
		HWX72300010	n/a	n/a	✓	n/a
		HWX72300024	n/a	n/a	n/a	✓
27	/	/	/	/	/	/
28	Compresseur	HWX80100108	✓	✓	n/a	n/a
		HWX80100046	n/a	n/a	✓	✓

## 6. ANNEXES (suite)

HP5091DT3HA / HP5111DT3HA / HP5151DT3HA / HP5181DT3HA

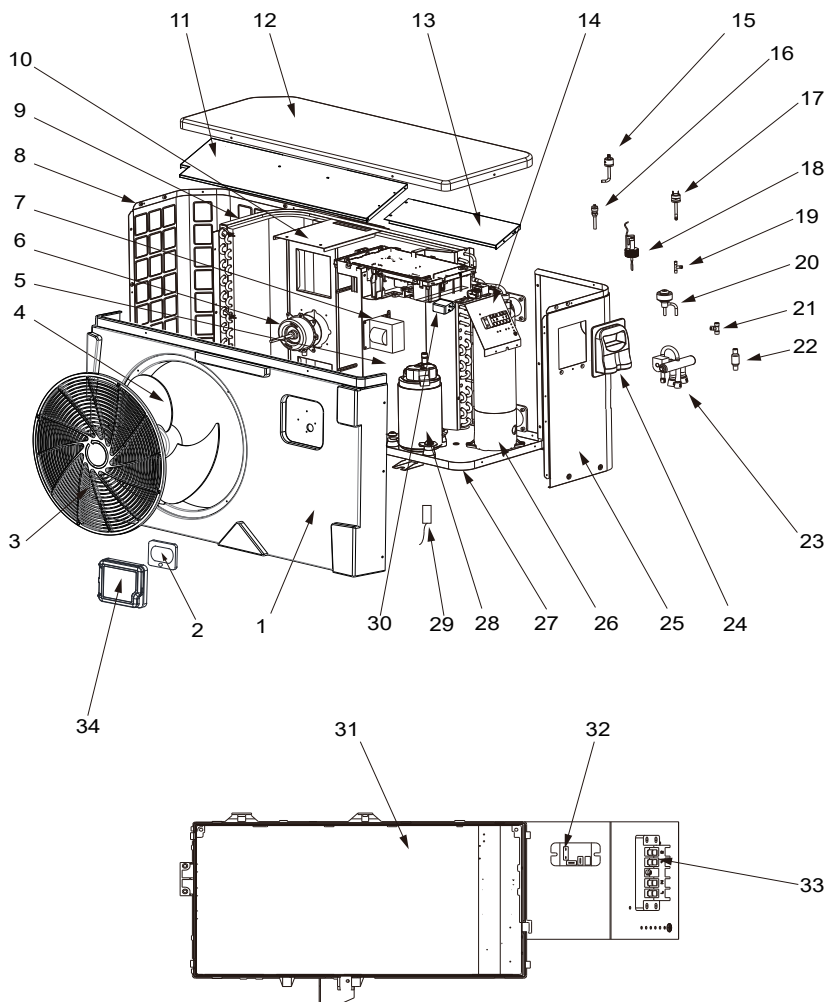

## 6. ANNEXES (suite)

Rep	Désignation	Réf.	HP5091DT3HA	HP5111DT3HA	HP5151DT3HA	HP5181DT3HA
29	Sonde Aspiration Compresseur 5 k - 560 mm	HWX83000044	✓	✓	n/a	n/a
	Sonde Aspiration Compresseur 5 k - 760 mm	HWX83000053	n/a	n/a	✓	✓
	Sonde température Air 5 k - 350 mm	HWX83000049	✓	✓	✓	✓
	Sonde Sortie d'eau 5 k - 410 mm	HWX83000050	✓	✓	✓	✓
	Sonde Entrée d'eau 5 k - 850 mm	HWX83000052	✓	✓	✓	n/a
	Sonde Entrée d'eau 5 k - 980 mm	HWX83000055	n/a	n/a	n/a	✓
	Sonde Refoulement Compresseur 50 k - 660 mm	HWX83000026	✓	✓	✓	✓
	Sonde de dégivrage 5 k - 680 mm	HWX83000051	✓	✓	n/a	n/a
	Sonde de dégivrage 5 k - 1040 mm	HWX83000045	✓	✓	✓	✓
30	Filtre EMC	HWX20003257	n/a	n/a	✓	✓
31	Carte électronique Driver	HWX72200168AP3	✓	n/a	n/a	n/a
		HWX72200168AP4	n/a	✓	n/a	n/a
		HWX72200167AP5	n/a	n/a	✓	n/a
		HWX72200167AP6	n/a	n/a	n/a	✓
32	Relais K2	HWX20000360297	✓	✓	✓	✓
33	Bornier L-N-GND -5 connexions 4 mm <sup>2</sup>	HWX40003901	✓	✓	✓	✓
34	Porte de protection	HWX80900321	✓	✓	✓	✓

## 6. ANNEXES (suite)

### 6.4 Guide de dépannage





*Certaines opérations doivent être réalisées par un technicien habilité.*

En cas de défaut sur la pompe à chaleur, le symbole  apparaît dans l'angle supérieur gauche de l'écran.

Pour plus de détail, consulter le tableau ci-après.



*Après résolution du problème l'erreur est acquitée automatiquement, le triangle disparaît.*

- Pour effacer la liste d'erreur, appuyer sur  .
- Presser 2 fois sur  pour revenir à l'écran principal.

## 6. ANNEXES (suite)

Dysfonctionnement	Codes d'erreur	Description	Solution
Défaut sonde entrée d'eau	P01	Le capteur est ouvert ou en court circuit	Vérifier la connectique CN21/RES1 sur la carte et le connecteur rallonge ou remplacer le capteur
Défaut sonde de sortie d'eau	P02		Vérifier la connectique N22/RES2 sur la carte et le connecteur rallonge ou remplacer le capteur
Défaut sonde température extérieure	P04		Vérifier la connectique CN12/PH sur la carte et le connecteur rallonge ou remplacer le capteur
Défaut sonde dégivrage	P05		Vérifier la connectique CN8/OPT sur la carte et le connecteur rallonge ou remplacer le capteur
Défaut sonde d'aspiration Compresseur	P07		Vérifier la connectique CN7/OAT sur la carte et le connecteur rallonge ou remplacer le capteur
Défaut sonde de refolement Compresseur	P081		Vérifier la connectique CN9/OHT sur la carte et le connecteur rallonge ou remplacer le capteur
Défaut Haute pression	E01	Le capteur est ouvert ou en court circuit	<p>Vérifier la connectique CN30/HP sur la carte ou remplacer le capteur</p> <p>Vérifier le débit d'eau</p> <p>Vérifier le détecteur de débit d'eau</p> <p>Vérifier l'ouverture des vannes</p> <p>Vérifier le by-pass</p> <p>Vérifier l'encrassement de l'évaporateur</p> <p>Température d'eau trop chaude</p> <p>Problème d'incondensable après une maintenance, vider et tirer au vide le circuit frigorifique</p> <p>Charge de fluide trop importante, retirer du fluide dans une bouteille de liquide</p>
Défaut basse pression	E02	Le capteur est ouvert ou en court circuit	<p>Vérifier la connectique CN31/LP sur la carte ou remplacer le capteur</p> <p>Fuite importante de fluide frigorigène, faire une recherche de fuite au détecteur</p> <p>Débit d'air trop faible, vérifier la vitesse de rotation du ventilateur</p> <p>Vérifier l'encrassement de l'évaporateur, nettoyer sa surface</p>
Défaut détecteur de débit	E03	Le capteur est ouvert ou en court circuit	<p>Vérifier la connectique CN29/OVT sur la carte ou remplacer le capteur</p> <p>Manque d'eau, vérifier le fonctionnement de la pompe de filtration</p> <p>Vérifier l'ouverture des vannes d'arrêts</p> <p>Vérifier le réglage du by-pass</p>

## 6. ANNEXES (suite)

Dysfonctionnement	Codes d'erreur	Description	Solution
Différence de température Entrée/Sortie > 13°C	E06	Applicable en mode Froid seulement	Manque d'eau, vérifier le fonctionnement de la pompe de filtration
			Vérifier l'ouverture des vannes d'arrêts
			Vérifier le réglage du by-pass
Protection Anti-gel	E07	Température de sortie d'eau < à 4°C	Stopper la pompe à chaleur, vidanger le condenseur risque de gel
Problème de communication	E08	Pas de communication entre la carte électronique et l'interface utilisateur	Vérifier les raccordements et la connectique - voir schéma électrique
Protection Anti-gel de niveau 1	E19	2°< Température d'eau <4° et Température d'air <0°	Arrêter le fonctionnement de la pompe à chaleur, vidanger le condenseur pour éviter le gel, par défaut la pompe à chaleur démarre la pompe de filtration pour éviter la prise en glace
Protection Anti-gel de niveau 2	E29	Températures d'eau < à 2° et Température d'air < 0°	Arrêter le fonctionnement de la pompe à chaleur, vidanger le condenseur pour éviter le gel, par défaut la pompe à chaleur démarre la pompe de filtration et la pompe à chaleur pour éviter la prise en glace.
Défaut moteur ventilateur	F031	Moteur bloqué ou défaut de connexion	Vérifier la libre rotation; vérifier la connectique CN97/DCFan; remplacer le moteur
Défaut moteur ventilateur	F051	Défaut de connexion	Vérifier la connectique DCFAN/CN97 ; remplacer le moteur
Température extérieure trop basse	TP	Limite de fonctionnement atteinte	Arrêter la pompe à chaleur



## 6. ANNEXES (suite)

### 6.5 Garantie

#### CONDITIONS DE GARANTIE

Tous les produits HAYWARD sont garantis contre tous vices de fabrication ou de matière pendant une période de deux années à compter de la date d'achat. Toute demande de garantie devra être accompagnée d'une preuve d'achat justifiant sa date. Nous vous incitons donc à conserver votre facture.

La garantie HAYWARD est limitée à la réparation ou au remplacement, au choix d'HAYWARD, des produits défectueux pour autant qu'ils aient subi un emploi normal, en accord avec les prescriptions mentionnées dans leur manuel d'utilisation, que le produit n'ait été modifié d'aucune sorte et utilisé uniquement avec des composants et des pièces HAYWARD. Les dommages dus au gel et aux attaques d'agents chimiques ne sont pas garantis.

Tous les autres frais (transport, main d'œuvre...) sont exclus de la garantie.

HAYWARD ne pourra être tenu pour responsable d'aucun dommage direct ou indirect provenant de l'installation, du raccordement ou du fonctionnement incorrect d'un produit.

Pour faire jouer une garantie et demander la réparation ou le remplacement d'un article, adressez vous à votre revendeur. Aucun retour de matériel à notre usine ne sera accepté sans notre accord écrit préalable.

Les pièces d'usure ne sont pas couvertes par la garantie.

### 6.6 Fin de vie de l'appareil



Le symbole de la poubelle barrée relatif au traitement et à la revalorisation des déchets électriques et électroniques signifie qu'en aucun cas les produits ne doivent être jetés avec les ordures ménagères, avec les encombrants ou dans une décharge.

En fin de vie, l'appareil doit faire l'objet d'une collecte sélective en vue de son recyclage ou de sa revalorisation. Un circuit spécifique de récupération pour ce type de produits est mis en place dans les pays de l'Union Européenne et en Norvège.

Contactez l'installateur ou le représentant local pour procéder à la collecte, au démantèlement et recyclage de cet appareil.

Le retraitement du liquide réfrigérant, de l'huile et des autres pièces doit être réalisé par un professionnel qualifié agréé conformément aux législations locales et nationales en vigueur.

Si le produit renferme des piles qui portent ce symbole, cela signifie que les piles peuvent contenir des substances nocives ou polluantes. Dans ce cas, déposez les piles dans un point de collecte de piles usagées.

*Page laissée blanche intentionnellement*



# HAYWARD<sup>®</sup>

## *FULL INVERTER*

SWIMMING POOL HEAT PUMP UNIT



HP5091DT3HA	HP5111DT3HA	HP5151DT3HA	HP5181DT3HA
-------------	-------------	-------------	-------------

**Installation & Instruction Manual**

# CONTENTS

---

<b>1. GENERAL INSTRUCTIONS - SAFETY</b>	<b>1</b>
<hr/>	
<b>2. TECHNICAL SPECIFICATIONS</b>	<b>5</b>
2.1 Heat pump technical data	5
2.2 Operating range	6
2.3 Dimensions	7
<hr/>	
<b>3. INSTALLATION AND CONNECTION</b>	<b>8</b>
3.1 Functional Diagram	8
3.2 Heat pump unit	8
3.3 Hydraulic connection	10
3.4 Electrical connection	11
3.5 Initial start-up	12
3.6 Water flow setting	14
<hr/>	
<b>4. USER INTERFACE</b>	<b>15</b>
4.1 General presentation	15
4.2 Timer function settings	17
4.3 Setting the On/Off timers	18
4.4 Adjust setpoint	20
4.5 Locking and unlocking the touch screen	21
4.6 SILENT function settings	22
<hr/>	
<b>5. MAINTENANCE AND WINTERISING</b>	<b>25</b>
5.1 Maintenance	25
5.2 Winterising	25
<hr/>	
<b>6. APPENDIX</b>	<b>26</b>
6.1 Electrical diagrams	26
6.2 Heating priority wiring for monophasic pump	28
6.3 Exploded view and spare parts	30
6.4 Troubleshooting guide	34
6.5 Warranty	37
6.6 End of life of the device	37

Please read attentively and save for future consultation.

This document must be given to the pool owner and should be kept in a safe place.

# 1. GENERAL INSTRUCTIONS - SAFETY

---

Thank you for purchasing the Hayward heat pump for swimming pools. The Hayward FULL INVERTER heat pump has been designed to strict manufacturing standards meeting the highest levels of quality required.

Hayward heat pumps offer you exceptional performance throughout your bathing season by adapting wattage, power usage and noise levels to the heating requirements of your swimming pool thanks to FULL INVERTER control logic.



***Read the instructions in this manual carefully before using the device.***

This manual includes all the necessary information for installation, trouble-shooting and maintenance.

Read this manual carefully before opening the unit or doing any maintenance work on it. The manufacturer of this product shall on no account accept any liability for injury to a user or damage to the unit further to any errors made during installation, trouble-shooting or unnecessary maintenance. It is particularly important to follow the instructions given in this manual at all times.

After having read this manual, keep it for future usage.

## **Authorised personnel**

- The installation, electrical connections, maintenance and repairs of the device must be carried out by an accredited professional in accordance with the regulatory texts and the rules of the art in effect in the country where the device is installed (see § 3.4).

For any intervention on the cooling circuit, the professional must hold a certificate of competence in handling refrigerants.

For France:

- Low-voltage electrical installation according to NF-C 15-100.
- Legislation on the handling of refrigerants: Decree 2007/737 and its implementation orders.

# 1. GENERAL INSTRUCTIONS - SAFETY (continued)

## This product contains refrigerant gas R32



*This device contains R32.*

***Never use a refrigerant other than R32. Any other gaseous body mixed with R32 could cause abnormally high pressure and lead to a failure or pipes bursting and injuring people.***

***During repairs or maintenance operations, use copper tubes that comply with Standard NF EN 12375-1 and with European Pressure Equipment Directive 97/23/EC.***

***As the heat pump is pressurized, never pierce the pipes or attempt any brazing. There is a risk of explosion.***

***Never expose the device to flames, sparks or other sources of ignition. It could explode and cause serious or even fatal injuries.***

***To detect refrigerant leaks: do not use a halide lamp or any other detector that uses an open flame. Do not use potential sources of ignition under any circumstances.***

This product contains fluorinated greenhouse gases regulated by the Kyoto protocol. Do not release these gases into the atmosphere.

GWP(1) value: 675, based in the 4th report of the IPCC.

Security group: A2L.

The quantity of refrigerant, based on the F-Gas regulation no. 517/2014, is stated on the unit's rating plate.

Any intervention on the cooling circuit must be carried out by an accredited professional as mentioned hereinabove.

Periodic inspections for leaks of refrigerant may be required by European or local legislation. Please contact your local distributor for more information.

- Warning, refrigerants can be odourless.
- Do not pierce or heat the pipes, risk of explosion and serious burns.
- Do not use a method for accelerating the defrosting or cleaning process other than those recommended by the manufacturer.
- The device must be stored in a room that does not contain any source of ignition operating on a permanent basis (for example, open flames, gas device or electric radiator that is operating).

(1) Global warming potential

# 1. GENERAL INSTRUCTIONS - SAFETY (continued)

## Installation conditions

- This heat pump is designed exclusively to heat swimming pool water; do not use this equipment for any other purpose.
- Do not attempt to install this device by yourself.
- If you detect a fault or any abnormal situation, do not install the heat pump and contact your dealer immediately.
- If kept in storage, the heat pump should be kept in a well-ventilated room with a floor area of more than  $A_{\min}$  (m<sup>2</sup>) as calculated by the following formula:  
$$A_{\min} = (M / (2.5 \times 0.22759 \times h_0))^2$$

M is the quantity of refrigerant in the device in kg, and h<sub>0</sub> is the storage height. If stored on the floor, h<sub>0</sub> = 0.6 m.
- This product was designed exclusively for domestic use and installation outdoors. The air that escapes from the product must be able to flow freely and must not be used for other purposes such as heating or cooling a room or building.
- Check the power cable. If the power cable is damaged, it has to be replaced by the manufacturer, its after-sales service or by a qualified and authorised person.
- Grounding connection of the device and its continuity are mandatory. The ground wire has to be longer than the other wires in order to prevent the risks of electric shock in the event the cable is pulled out. The electrical installation must be equipped with a differential protection of 30 mA (see § 3.4).
- Make sure the support provided for the unit is strong enough to bear the weight of the unit.
- **Failure to comply with recommendations will invalidate the warranty.**

## Instructions for servicing - maintenance

Maintenance operations must be carried out once per year in order to guarantee the longevity and the good working condition of the heat pump.

- Maintenance and the different operations must be carried out at the recommended times and frequencies as specified in this manual.
- Only use genuine spare parts.
- Check the power cable. If the power cable is damaged, it has to be replaced by the manufacturer, its after-sales service or by a qualified and authorised person.
- Verify the grounding connection of the device and its continuity.
- Clean the coil with the help of a soft brush or jet of air or water. **Warning, never use a high pressure cleaner.**

# 1. GENERAL INSTRUCTIONS - SAFETY (continued)

- Verify that the drains flow well.
- Verify the tightening of the hydraulic and electrical connections
- Verify the hydraulic sealing of the condenser.
- Have the leak-tightness of the cooling circuit to the leak detector checked by an **accredited professional**.



***Before any maintenance operation, the heating pump must be disconnected from any electrical current source. The maintenance operations must only be carried out by personnel that is qualified and authorised to handle liquid refrigerants.***

## Instructions for winterising

- Put the heat pump in “OFF” mode.
- Cut the power supply to the heat pump.
- Empty the condenser with the help of the drain to avoid any risk of deterioration. (high risk of freezing).
- Close the by-pass valve and unscrew the entry/exit connection unions.
- Eliminate the maximum amount of residual stagnant water from the condenser with the help of an air gun.
- Close the water entry and exit areas of the heating pump to avoid introducing foreign bodies.
- Cover the heating pump with a dedicated winterising case.



***Any damage caused by poor winterising maintenance will lead to cancellation of the warranty.***

## Conditions for use

This device can be used by children aged 8 years and over as well as by persons who have reduced, physical, sensory or mental capacities, or who lack experience or knowledge, if they are correctly monitored or if instructions pertaining to the use of the device in complete safety have been given to them and the risks incurred are understood.

Children must not play with the device.

Cleaning and maintenance by the user must not be carried out by children without surveillance.



## 2. TECHNICAL SPECIFICATIONS

### 2.1 Heat pump technical data

Models	FULL INVERTER	HP5091DT3HA	HP5111DT3HA	HP5151DT3HA	HP5181DT3HA
Supply voltage	V	220V-240V ~/1ph/50Hz			
Refrigerant	/	R32			
Load	kg	0.430	0.450	0.60	0.670
Mass in teqCO <sub>2</sub>	/	0.29	0.30	0.41	0.45
Leak check frequency	/	No specific frequency, but an annual check is recommended			
Min--Max heating capacity <sup>(a)</sup>	kW	2.46 -- 9.17	2.36 -- 11.45	3.31 -- 15.90	3.2 -- 18.15
Min--Max electric input power <sup>(a)</sup>	kW	0.17 -- 1.45	0.17 -- 1.80	0.27 -- 2.84	0.22 -- 3.13
Min--Max continuous current rating <sup>(a)</sup>	A	1.17 -- 6.42	1.19 -- 7.85	1.37 -- 12.35	1.45 -- 13.58
Max--Min continuous power (COP) <sup>(a)</sup>	/	14.37 -- 6.32	13.88 -- 6.35	12.26 -- 5.59	14.34 -- 5.80
Min--Max heating capacity <sup>(b)</sup>	kW	1.75 -- 7.05	1.56 -- 8.00	3.05 -- 12.40	2.86 -- 14.11
Min--Max electric input power <sup>(b)</sup>	kW	0.27 -- 1.51	0.279 -- 1.74	0.42 -- 2.65	0.43 -- 2.99
Max--Min continuous power (COP) <sup>(b)</sup>	/	6.40 -- 4.65	5.60 -- 4.80	7.26 -- 4.68	6.63 -- 4.71
Maximum continuous current	A	8.40	9.50	14	15.9
Fuse rating	aM	10	12	16	20
Circuit-breaker curve D	D	10	12	16	20
Starting current	A	< maximum continuous current			
Hydraulic connection	mm	50 mm			
Nominal water flow <sup>(a)</sup>	m <sup>3</sup> /h	4.00	5.00	6.70	7.70
Max. loss of head on water	kPa	3.80	4.0	6.3	10
Compressor	/	DC Inverter Panasonic		DC Inverter Mitsubishi	
Type	/	Twin rotary		Twin rotary	
Quantity	/	1			
Coil resistance at 20°C	Ohm	1.208		0.95	
Fan	/	Axial			
Quantity		1			
Diameter	mm	405		510	
Number of blades	/	3			
Motor	/	DC Inverter			
Quantity	/	1			
Rotation speed	rpm	400 -- 700	500 -- 850	300 -- 750	400 -- 750
Silent mode speed	rpm	400	500	300	400
Sound pressure level at 1 meter	dB(A)	50.2	53.9	50.8	54.0
Sound pressure level at 10 meters	dB(A)	32.8	34.2	33.8	37.25
Unit's net dimensions (L-W-H)	mm	1003 / 418 / 605		1048 / 437 / 768	1161 / 473 / 862
Weight	kg	44	45	66	70

(a) Dry air 27°C - Relative humidity 78% - Water inlet temperature 26°C.



(b) Dry air 15°C - Relative humidity 71% - Water inlet temperature 26°C

## 2. TECHNICAL SPECIFICATIONS (continued)

---

### 2.2 Operating range

Use the swimming pool heat pump unit within the following ranges of temperature and humidity to ensure safe and efficient operation.

	Heating mode 	Cooling mode 
Outside temperature	-7°C – +35°C	+7°C – +43°C
Water temperature	+12°C – +32°C	+8°C – +40°C
Relative humidity	< 80%	< 80%
Setting range from the set point	+15°C – +32°C	+8°C – +32°C



***If the temperature or humidity does not correspond to these conditions, the security measures could be activated and the swimming pool heat pump unit may no longer work.***



***The maximum heating temperature is set at 32°C to prevent damage to the liners. Hayward cannot be held responsible if used at a temperature above +32°C.***

## 2. TECHNICAL SPECIFICATIONS (continued)

### 2.3 Dimensions

Models:

HP5091DT3HA / HP5111DT3HA / HP5151DT3HA / HP5181DT3HA

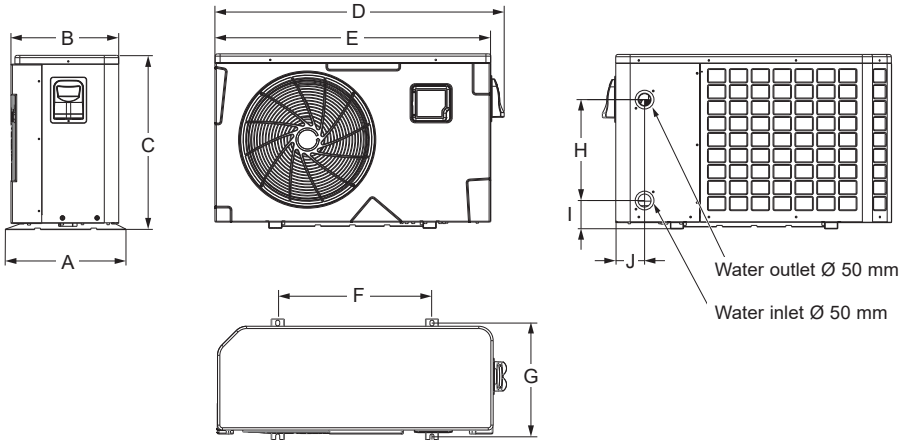

Unit: mm

Size \ Type	HP5091DT3HA / HP5111DT3HA	HP5151DT3HA	HP5181DT3HA
<b>A</b>	418	436,5	473
<b>B</b>	374	418	451,5
<b>C</b>	604,5	767,5	862
<b>D</b>	1003	1047,5	1160,5
<b>E</b>	956	1002	1115
<b>F</b>	535	615	790
<b>G</b>	394,5	410	447
<b>H</b>	350	350	466
<b>I</b>	97,7	101,2	97,6
<b>J</b>	99,2	106,5	113,5

### 3. INSTALLATION AND CONNECTION

#### 3.1 Functional Diagram

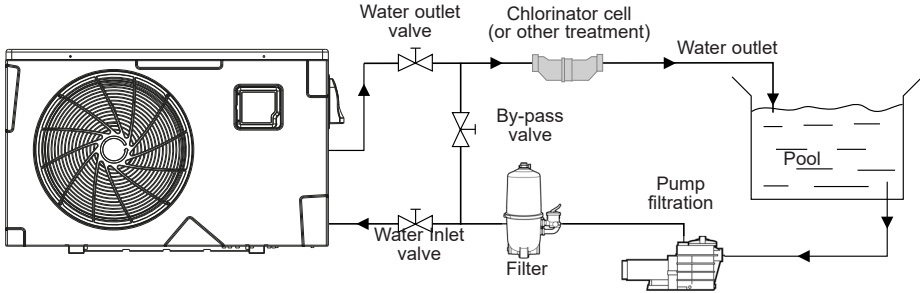

Note: The swimming pool heat pump unit is sold without any treatment or filtration equipment. The components presented in the diagram are spare parts to be supplied by the installer.

#### 3.2 Heat pump unit



**Place the heat pump outdoors and away from any enclosed technical space.**

**Choose a location that is preferably sunlit and sheltered from dominant winds.**

**The device must be perfectly accessible for later installation and maintenance work.**

**Placed under a shelter, the minimum required distances mentioned below must be respected in order to avoid any risk of air recirculation and a deficiency in the unit's overall performance.**

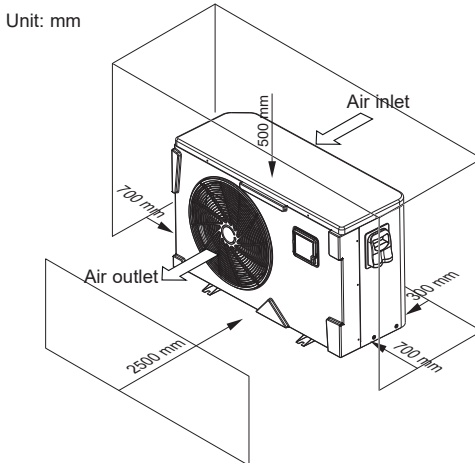

### 3. INSTALLATION AND CONNECTION (continued)



**Do not position the device directly on the floor because this could cause problems.**

**Favour positioning on the ground on anti-vibration studs.**

**A wall bracket must not be used in conditions that can transmit vibrations.**

**Do not install the heat pump on a support that risks intensifying the unit's vibrations.**

**Do not install the heat pump anywhere liable to amplify its noise level or anywhere where its noise could disturb neighbours.**

**Do not use adhesives: the latter are not considered to be a reliable means of fastening.**

**Preferably, install the heat pump on a flat and dissociated cement block. Set up the unit on the supplied rubber bushing (fastenings and washers supplied).**

**Fasten the device, in compliance with the tightening indicated to avoid any risk of accident or damage to equipment and persons.**

**Another possibility: install the heat pump on rubber floor supports using suitable fastenings (not supplied).**

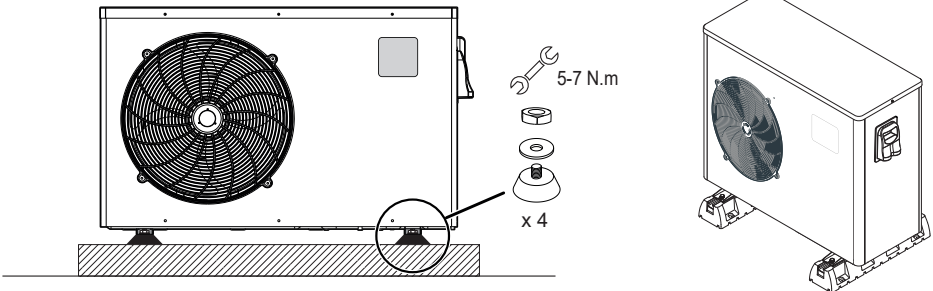

**The maximum installation distance between the unit and the swimming pool is 15 metres.**

**The total length of the piping to and from the unit is 30 metres.**

**Insulate both the above ground and buried hydraulic piping.**

**The heat pump must be installed at a minimum distance from the pool in compliance with NF C 15-100 (3.5 m from the water for France) or in compliance with installation standards applicable in other countries.**

**Do not install the heat pump close to a heat source.**

**For installation in snowy regions we recommend sheltering the machine to avoid snow accumulating on the evaporator.**

## 3. INSTALLATION AND CONNECTION (continued)

---

### 3.3 Hydraulic connection

The unit is supplied with two 50 mm Ø union connections. Connect the water inlet to the heat pump coming from the filtration group then connect the water outlet to the heat pump at the water conduit going to the pool (see diagram below).

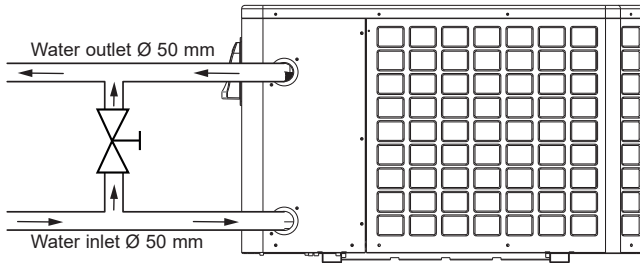

Install a by-pass valve between the heat pump entrance and exit.



***If an automatic distributor or an electrolyser is used, it should be installed imperatively after the heat pump with the goal of protecting the titanium condenser against an elevated concentration of chemicals.***



***Be sure to install the by-pass valve and the supplied union connections at the water inlet and outlet level in order to simplify purging during the winter period and to facilitate access when disassembling for maintenance.***

### 3. INSTALLATION AND CONNECTION (continued)

#### 3.4 Electrical connection



**Electrical installation and wiring for this equipment must be in conformity with local installation standards.**

F	NF C15-100	GB	BS7671:1992
D	DIN VDE 0100-702	EW	EVHS-HD 384-7-702
A	ÖVE 8001-4-702	H	MSZ 2364-702/1994/MSZ 10-553 1/1990
E	UNE 20460-7-702 1993, RECBT ITC-BT-31 2002	M	MSA HD 384-7-702.S2
IRL	Wiring Rules + IS HD 384-7-702	PL	PN-IEC 60364-7-702:1999
I	CEI 64-8/7	CZ	CSN 33 2000 7-702
LUX	384-7.702 S2	SK	STN 33 2000-7-702
NL	NEN 1010-7-702	SLO	SIST HD 384-7-702.S2
P	RSIUEE	TR	TS IEC 60364-7-702



**Verify that the available electrical power supply and the network frequency correspond to the required operating current taking into account the appliance's specific location, and the current required to supply any other appliance connected to the same circuit.**

**HP5091DT3HA / HP5111DT3HA / HP5151DT3HA / HP5181DT3HA  
230V $\sim$  +/- 10 % 50 Hz 1 Phase**

**See the corresponding wiring diagram in the appendix.  
The connection box is located on the right side of the unit. Three connections are designed for the power supply and two are for controlling the filter pump (Enslavement).**

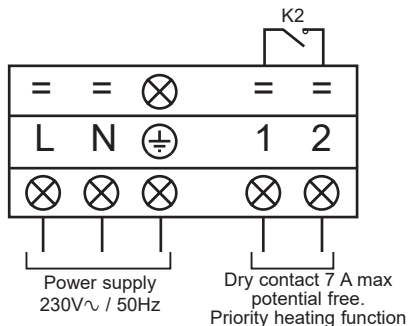

## 3. INSTALLATION AND CONNECTION (continued)

---



**Never use an electrical plug for the power supply.**

**The electrical power supply must have, in a suitable manner, an omnipolar protection device of the D-curve circuit breaker type as well as a 30mA protection differential circuit breaker (see following table).**

Models		HP5091DT3HA	HP5111DT3HA	HP5151DT3HA	HP5181DT3HA
Power supply	V/Ph/Hz	230V~ 50Hz	230V~ 50Hz	230V~ 50Hz	230V~ 50Hz
Curve D circuit breaker	A	8 D	10 D	16 D	20 D
Cable section	mm <sup>2</sup>	3G 2,5	3G 2,5	3G 2,5	3G 4



**Use an RO 2V/R 2V or equivalent power cord.**



**The cables sections are given for a maximum length of 25 m. They must however be checked and adjusted according to the installation conditions.**



**Always shut down the main power supply before opening the electrical control box.**

**After a cut-off of the power supply, wait 10 minutes before accessing the active internal parts of the equipment (power stored in the capacitors).**

### 3.5 Initial start-up

Start-up procedure - After installation is complete, follow these steps:

- 1) Rotate the fans by hand to verify that they can turn freely by hand, and that the turbine is correctly affixed to the motor shaft.
- 2) Ensure that the unit is connected correctly to the main power supply (see the wiring diagram in the appendix).
- 3) Activate the filtration pump.
- 4) Verify that all water valves are open and that the water flows toward the unit before switching on the heating or cooling mode.
- 5) Verify that the drainage hose is correctly affixed and that it causes no obstructions.
- 6) Activate the unit power supply, then press the On/Off button  on the control panel.



### 3. INSTALLATION AND CONNECTION (continued)

---

- 7) Make sure the alarm or lock symbols are not displayed. If need be, see the trouble-shooting guide (see § 6.4).
- 8) Set the water flow using the by-pass valve (see § 3.6 and 2.1), as provided for by each model, to obtain an Entry/Exit temperature of 2°C.
- 9) After running for several minutes, verify that the air exiting the unit is cool (between 5 and 10°).
- 10) With the unit operating, turn off the filter pump. The unit should automatically turn off and display error code E03 (See § 6.4).
- 11) Allow the unit and the pool pump to run 24 hours per day until the desired water temperature has been reached. When the set water inlet temperature is reached, the unit will turn off. It will automatically restart (as long as the pool pump is running) if the pool temperature is at least 0.5°C below the set temperature.

**Water flow switch** - The unit is equipped with a flow switch that turns on the heat pump when the pool filtration pump is running, and deactivates it when the filtration pump is out of order. If the water is low, the E03 alarm code will appear on the regulator (See § 6.4).

**Time delay** - The unit is equipped with a time delay of 3 minutes in order to protect the control circuit components, to eliminate restart cycling and contactor chatter. Thanks to this time delay, the unit automatically restarts approximately 3 minutes after each control circuit interruption. Even a brief power interruption will activate the restart time delay.

## 3. INSTALLATION AND CONNECTION (continued)

---

### 3.6 Water flow setting

With the water entry and exit valves being open, adjust the by-pass valve in order to obtain a difference of 2°C between the inflow and outflow temperature (see principle diagram § 3.1). You can verify the switch by seeing the entry/exit temperatures directly on the control panel.



Note: Opening the by-pass valve creates a weaker flow, which leads to an increase in  $\Delta T$ .

Closing the by-pass valve creates a stronger flow, which leads to a decrease in  $\Delta T$ .

# 4. USER INTERFACE

## 4.1 General presentation

The heat pump is equipped with a digital control panel with a touch screen, electronically connected and pre-set at the factory in heating mode.

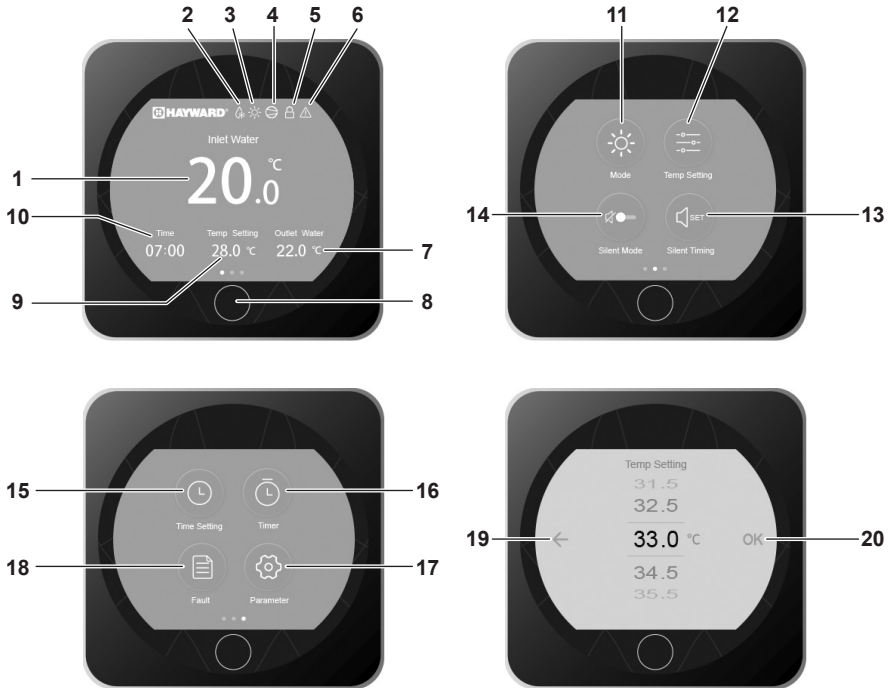

### Legend

1	Water Input temperature
2	Defrost mode
3	Operating mode
4	Compressor's ON indicator
5	Lock screen
6	Alarm
7	Water Output temperature
8	On/Off/Back
9	Setpoint temperature
10	Hour

11	Operating mode selection
12	Adjust setpoint
13	Setting silence mode timer
14	Activate silent mode
15	Set date and time
16	Set On/Off timers
17	Access Advanced Settings
18	Access list of faults
19	Back (changes not confirmed)
20	Confirm

## 4. USER INTERFACE (continued)

---

### OFF mode

When the heat pump is idle (in standby mode), OFF is displayed as shown on the screen.

The black screen indicates that the heat pump is idle; settings can be adjusted in this mode.



### ON mode

When the heat pump is running or priming (setpoint reached), the screen turns blue.



To switch from OFF to ON mode and vice versa, press the  button.

# 4. USER INTERFACE (continued)

## 4.2 Timer function settings

The date and time can be set either in ON or in OFF mode.



- Press 1 times on  to return to the main screen.

## 4. USER INTERFACE (continued)

### 4.3 Setting the On/Off timers

Setting this function is necessary if you would like to run the heat pump for a shorter period than what is defined by the filtration clock. Therefore, you can program a deferred start and an anticipated stop or simply stop a certain timeframe from running (at night, for example).

It is possible to set one Start Timer and one Stop Timer.  
The setting step is "hour to hour".



## 4. USER INTERFACE (continued)

---



**Blue highlighting = Activated**  
**Grey = Deactivated**

- Press 2 times on  to return to the main screen.

## 4. USER INTERFACE (continued)

### 4.4 Adjust setpoint

The setpoint can be changed either in ON or in OFF mode with an accuracy of 0.5°C.



- Press 1 times on  to return to the main screen.



*It is recommended to never exceed 30°C to avoid alteration of the liners.*



## 4. USER INTERFACE (continued)

### 4.5 Locking and unlocking the touch screen

The screen can be locked or unlocked either in ON or in OFF mode.



Lock activated



Lock deactivated

## 4. USER INTERFACE (continued)

---

### 4.6 SILENT function settings

Silence mode enables the heat pump to be used in economic and very silent mode when the heating needs are low (maintaining the pool temperature or need for ultra-silent operation).

This function can be Activated/Deactivated manually or using a Timer.

#### Activation/Deactivation

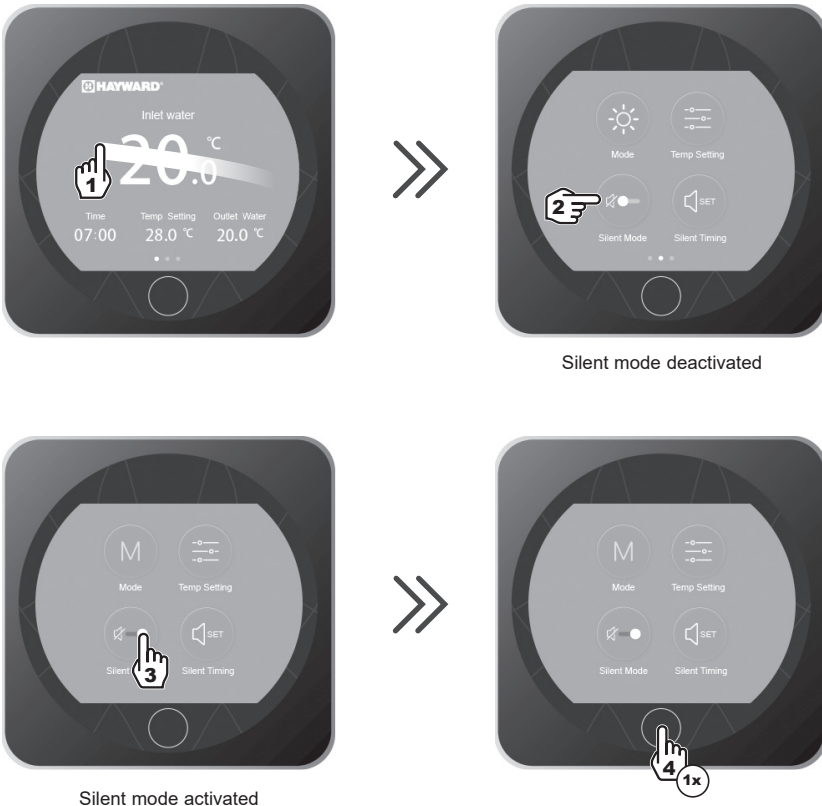

- Press 1 times on  to return to the main screen.

## 4. USER INTERFACE (continued)

---

### Adjusting the SILENT mode Timer



## 4. INTERFACE UTILISATEUR (suite)

---



- Press 2 times on  to return to the main screen.



***The setting step is "hour to hour".  
Once the Timer is activated, it is active 7 days a week.***

## 5. MAINTENANCE AND WINTERISING

---

### 5.1 Maintenance

These maintenance operations must be carried out once per year in order to guarantee the longevity and the good working condition of the heat pump.

- The maintenance and repairs of the device must be carried out by an accredited professional in accordance with the regulatory texts and the rules of the art in effect in the country where the device is installed (see § 3.4).  
For any intervention on the cooling circuit, the professional must hold a certificate of competence in handling refrigerants.
- Check the power cable. If the power cable is damaged, it has to be replaced by the manufacturer, its after-sales service or by a qualified and authorised person.
- Verify the grounding connection of the device and its continuity.
- Clean the coil with the help of a soft brush or jet of air or water. **Warning, never use a high pressure cleaner.**
- Verify that the drains flow well.
- Verify the tightening of the hydraulic and electrical connections
- Verify the hydraulic sealing of the condenser.
- Have the leak-tightness of the cooling circuit to the leak detector checked by an **accredited professional**.



***Before any maintenance operation, the heating pump must be disconnected from any electrical current source. The maintenance operations must only be carried out by personnel that is qualified and authorised to handle liquid refrigerants.***

### 5.2 Winterising

- Put the heat pump in “OFF” mode.
- Cut the power supply to the heat pump.
- Empty the condenser with the help of the drain to avoid any risk of deterioration. (high risk of freezing).
- Close the by-pass valve and unscrew the entry/exit connection unions.
- Eliminate the maximum amount of residual stagnant water from the condenser with the help of an air gun.
- Close the water entry and exit areas of the heating pump to avoid introducing foreign bodies.
- Cover the heating pump with a dedicated winterising case.



***Any damage caused by poor winterising maintenance will lead to cancellation of the warranty.***

# 6. APPENDIX

## 6.1 Electrical diagrams

### HP5091DT3HA / HP5111DT3HA

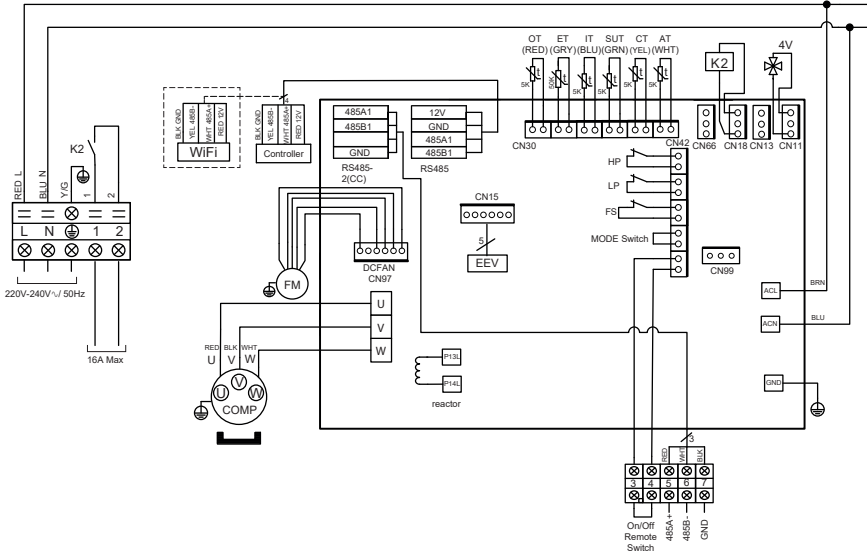

#### REMARKS

- |   |  |
|---|--|
| <b>AT:</b> AIR TEMPERATURE SENSOR         | <b>LP:</b> LOW PRESSURE SWITCH             |
| <b>COMP:</b> COMPRESSOR                   | <b>OT:</b> OUTLET WATER TEMPERATURE SENSOR |
| <b>CT:</b> EVAPORATOR TEMPERATURE SENSOR  | <b>SUT:</b> SUCTION TEMPERATURE SENSOR     |
| <b>EEV:</b> ELECTRONIC EXPANSION VALVE    | <b>4V:</b> 4 WAYS VALVE                    |
| <b>FM:</b> FAN MOTOR                      | <b>K2:</b> DRY CONTACT 16 A MAX            |
| <b>FS:</b> WATER FLOW SWITCH              | <b>ET:</b> DISCHARGE TEMPERATURE SENSOR    |
| <b>HP:</b> HIGH PRESSURE SWITCH           | ⋮ : OPTION                                 |
| <b>IT:</b> WATER INLET TEMPERATURE SENSOR |  |

# 6. APPENDIX (continued)

## HP5151DT3HA / HP5181DT3HA

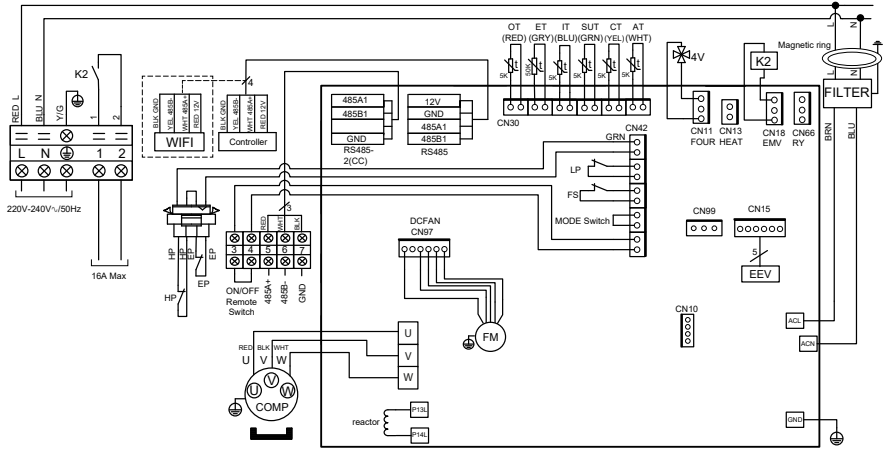

### REMARKS

- |   |  |
|---|--|
| <b>AT:</b> AIR TEMPERATURE SENSOR         | <b>LP:</b> LOW PRESSURE SWITCH             |
| <b>COMP:</b> COMPRESSOR                   | <b>OT:</b> OUTLET WATER TEMPERATURE SENSOR |
| <b>CT:</b> EVAPORATOR TEMPERATURE SENSOR  | <b>SUT:</b> SUCTION TEMPERATURE SENSOR     |
| <b>EEV:</b> ELECTRONIC EXPANSION VALVE    | <b>4W:</b> 4 WAYS VALVE                    |
| <b>FM:</b> FAN MOTOR                      | <b>K2:</b> DRY CONTACT 16 A MAX            |
| <b>FS:</b> WATER FLOW SWITCH              | <b>ET:</b> DISCHARGE TEMPERATURE SENSOR    |
| <b>HP:</b> HIGH PRESSURE SWITCH           | <b>---</b> (dashed box): OPTION            |
| <b>IT:</b> WATER INLET TEMPERATURE SENSOR |  |

# 6. APPENDIX (continued)

## 6.2 Heating priority wiring for monophasic pump

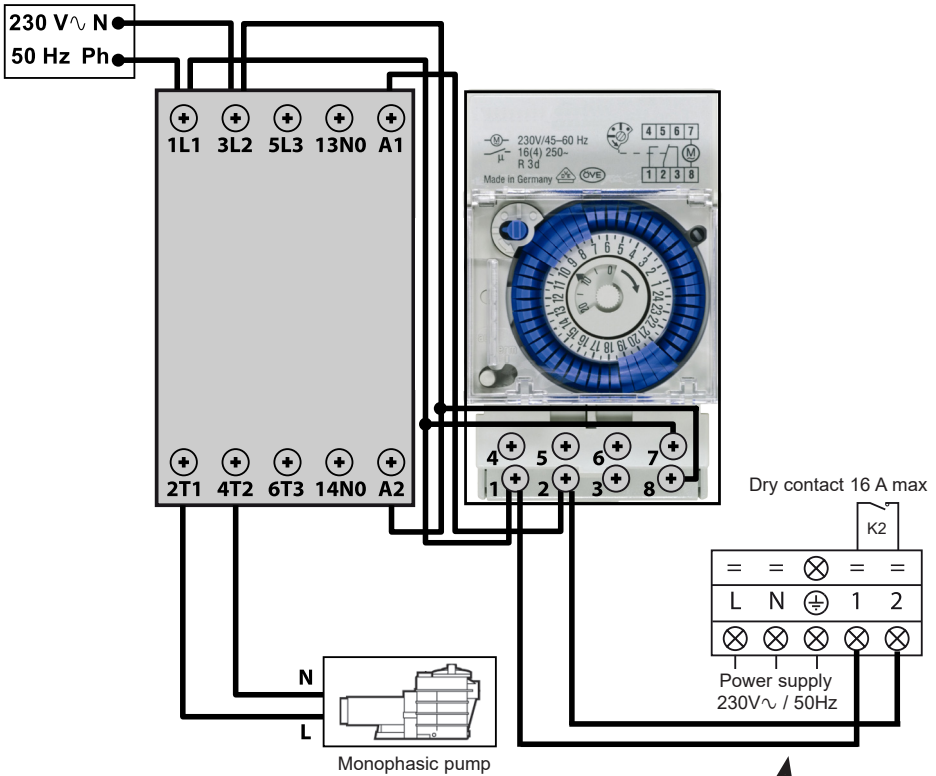

Terminals 1 and 2 deliver a potential-free dry contact, 230V~ / 50 Hz, no polarity.

Wire terminals 1 and 2 as indicated in the diagram above, to activate the operation of the filtration pump in 2-minute cycles each hour if the temperature of the pool is lower than the set point.

 Never connect the power supply of the filtration pump directly to terminals 1 and 2.





---

*Page left intentionally blank*

# 6. APPENDIX (continued)

## 6.3 Exploded view and spare parts

HP5091DT3HA / HP5111DT3HA / HP5151DT3HA / HP5181DT3HA

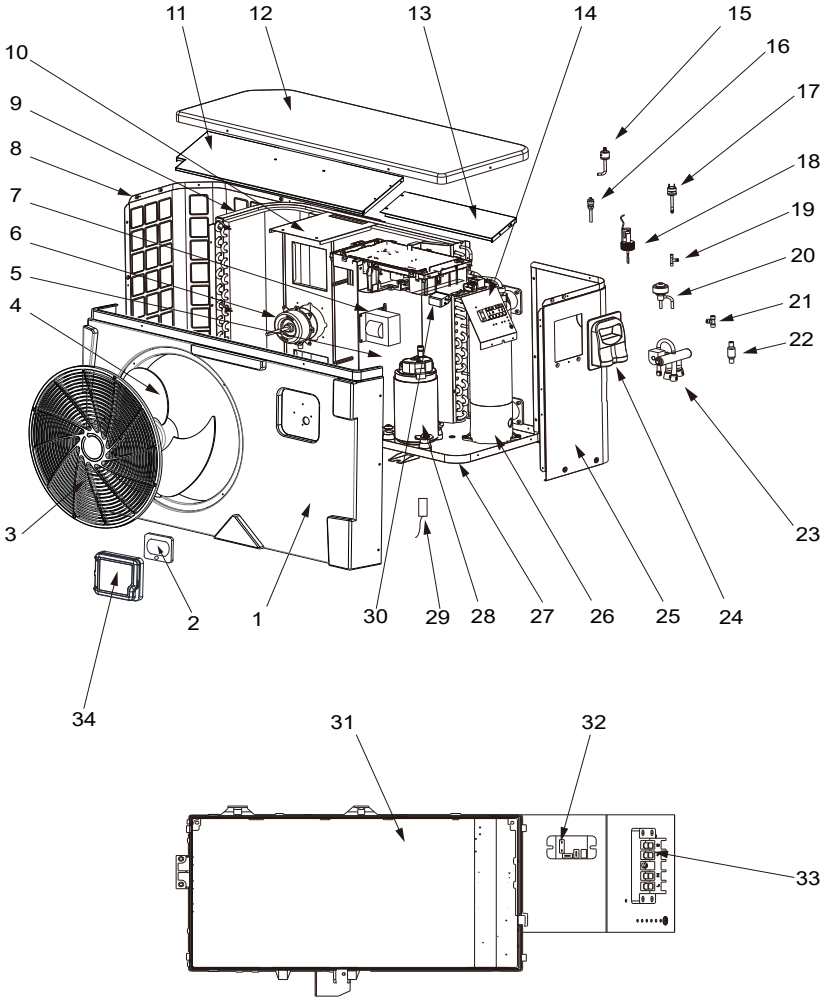

## 6. APPENDIX (continued)

Mark	Description	Ref.	HP5091DT3HA	HP5111DT3HA	HP5151DT3HA	HP5181DT3HA
1	Front panel	HWX80900843	✓	✓	n/a	n/a
		HWX80900844	n/a	n/a	✓	n/a
		HWX80900850	n/a	n/a	n/a	✓
2	LED controller	HWX72200070	✓	✓	✓	✓
3	Fan protection grille	HWX80900375	✓	✓	✓	n/a
		HWX20000220369	n/a	n/a	n/a	✓
4	Fan blade	HWX301030000006	✓	✓	n/a	n/a
		HWX301030000001	n/a	n/a	✓	✓
5	/	/	/	/	/	/
6	DC Fan Motor	HWX80200018	✓	✓	n/a	n/a
		HWX20000330132	n/a	n/a	✓	✓
7	16 A 50 Hz 5 mH coil	HWX82500020	✓	✓	n/a	n/a
	20 A 50 Hz 5.2 mH coil	HWX82500021	n/a	n/a	✓	✓
8	Left panel	HWX80702123	✓	✓	n/a	n/a
		HWX80700244	n/a	n/a	✓	n/a
		HWX80702268	n/a	n/a	n/a	✓
9	Fin coil	HWX80600042	✓	n/a	n/a	n/a
		HWX80600043	n/a	✓	n/a	n/a
		HWX80600044	n/a	n/a	✓	n/a
		HWX80600078	n/a	n/a	n/a	✓
10	Motor bracket	HWX80700218	✓	✓	n/a	n/a
		HWX80700248	n/a	n/a	✓	n/a
		HWX80700329	n/a	n/a	n/a	✓
11	/	/	/	/	/	/
12	Upper front panel	HWX80900055	✓	✓	n/a	n/a
		HWX301090200806	n/a	n/a	✓	n/a
		HWX80900076	n/a	n/a	n/a	✓
13	/	/	/	/	/	/
14	/	/	/	/	/	/
15	Low pressure switch NO 0.30 MPa / 0.15 MPa	HWX20000360157	✓	✓	✓	✓
16	Pressure Tap 40 mm-1/2"	HWX20000140150	✓	✓	✓	✓
17	High pressure switch NC 3.2 MPa/4.4 MPa	HWX20013605	✓	✓	✓	✓
18	Water flow detector	HWX83000068	✓	✓	✓	✓
19	T connector Ø 6.5-2 x Ø 6.5(T) x 0.75	HWX20001460	✓	✓	✓	✓
20	Electronic expansion valve	HWX81000011	✓	✓	n/a	n/a
		HWX81000013	n/a	n/a	✓	✓
21	T connector Ø 9.52-2 x Ø 6.35(T) x 1.0	HWX304030000002	✓	✓	✓	✓
22	Filter Ø 9.7-Ø 9.7 (Ø19)	HWX20000140178	✓	✓	n/a	n/a
	Filter Ø 9.7-Ø 9.7 (Ø28)	HWX20041444	n/a	n/a	✓	✓
23	4 ways valve	HWX20041437	✓	✓	✓	✓
24	Access hatch	HWX320922029	✓	✓	✓	✓
		HWX80700580	✓	✓	n/a	n/a
25	Right panel	HWX80700878	n/a	n/a	✓	n/a
		HWX80700581	n/a	n/a	n/a	✓
		HWX72300013	✓	n/a	n/a	n/a
26	Titanium / PVC condenser	HWX72300014	n/a	✓	n/a	n/a
		HWX72300010	n/a	n/a	✓	n/a
		HWX72300024	n/a	n/a	n/a	✓
27	/	/	/	/	/	/
28	Compressor	HWX80100108	✓	✓	n/a	n/a
		HWX80100046	n/a	n/a	✓	✓

# 6. APPENDIX (continued)

HP5091DT3HA / HP5111DT3HA / HP5151DT3HA / HP5181DT3HA

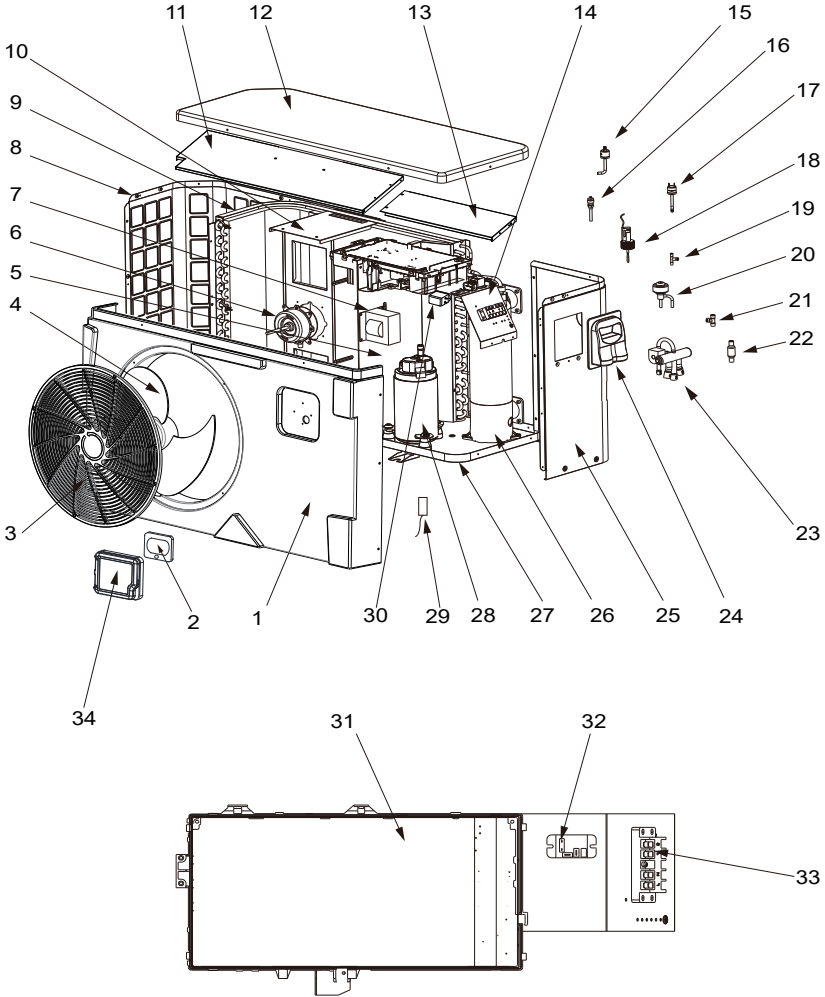

## 6. APPENDIX (continued)

Mark	Description	Ref.	HP5091DT3HA	HP5111DT3HA	HP5151DT3HA	HP5181DT3HA
29	Compressor aspiration sensor 5 k - 560 mm	HWX83000044	✓	✓	n/a	n/a
	Compressor aspiration sensor 5 k - 760 mm	HWX83000053	n/a	n/a	✓	✓
	Temperature sensor Air 5 k - 350 mm	HWX83000049	✓	✓	✓	✓
	Water outlet sensor 5 k - 410 mm	HWX83000050	✓	✓	✓	✓
	Water inlet sensor 5 k - 850 mm	HWX83000052	✓	✓	✓	n/a
	Water inlet sensor 5 k - 980 mm	HWX83000055	n/a	n/a	n/a	✓
	Compressor discharge probe 50 k - 660 mm	HWX83000026	✓	✓	✓	✓
	De-icing sensor 5 k - 680 mm	HWX83000051	✓	✓	n/a	n/a
	De-icing sensor 5 k - 1040 mm	HWX83000045	✓	✓	✓	✓
30	EMC Filter	HWX20003257	n/a	n/a	✓	✓
31	Printed circuit board Driver	HWX72200168AP3	✓	n/a	n/a	n/a
		HWX72200168AP4	n/a	✓	n/a	n/a
		HWX72200167AP5	n/a	n/a	✓	n/a
		HWX72200167AP6	n/a	n/a	n/a	✓
32	K2 relay	HWX20000360297	✓	✓	✓	✓
33	Terminal block L-N-GND 5 connections 4 mm <sup>2</sup>	HWX40003901	✓	✓	✓	✓
34	Waterproof cover	HWX80900321	✓	✓	✓	✓

## 6. APPENDIX (continued)

### 6.4 Troubleshooting guide



**Certain operations must be carried out by an authorized technician.**

If a fault occurs on the heat pump ⚠ appears in the top left-hand corner of the screen.

Refer to following table.



**When the problem is resolved, the error is automatically acknowledged and the triangle disappears.**

- To delete the error list, press on **Del**.
- Press 2 times on **○** to return to the main screen.

## 6. APPENDIX (continued)

Problem	Error codes	Description	Solution
Water inlet sensor fault	P01	The sensor is open or has short-circuited.	Verify the CN21/RES1 connectors on the board and the extension connector or replace the sensor
Water outlet sensor fault	P02		Verify the N22/RES2 connectors on the board and the extension connector or replace the sensor
Outside temperature sensor fault	P04		Verify the CN12/PH connectors on the board and the extension connector or replace the sensor
De-icing sensor fault	P05		Verify the CN8/OPT connectors on the board and the extension connector or replace the sensor
Compressor aspiration sensor defect	P07		Verify the CN7/OAT connectors on the board and the extension connector or replace the sensor
Compressor discharge sensor fault	P081		Verify the CN9/OHT connectors on the board and the extension connector or replace the sensor
High pressure protection	E01	The sensor is open or has short-circuited.	Verify the CN30/HP connectors on the card or replace the sensor Check the water flow Check the water flow detector Check the valve opening Check the by-pass Check the evaporator is not clogged Water temperature too hot Incondensable problem after maintenance, empty and evacuate the cooling circuit Fluid load too high, remove fluid into a liquid bottle
Low pressure protection	E02	The sensor is open or has short-circuited.	Check the AI/DI03 connections on the card or replace the sensor Large coolant leak, search for the leak with the detector Air flow too low, check the ventilator rotation speed Check the evaporator is not clogged, clean its surface
Flow sensor fault	E03	The sensor is open or has short-circuited.	Check the AI/DI02 connections on the card or replace the sensor Lack of water, check the filtration pump operation Check the stop valve opening Check the by-pass adjustment

## 6. APPENDIX (continued)

Problem	Error codes	Description	Solution
Input/Output temperature difference > 13°C	E06	Applicable in Cold mode only	Lack of water, check the filtration pump operation
			Check the stop valve opening
			Check the by-pass adjustment
Antifreeze protection Cold mode	E07	Water output temperature < 4°C	Stop the heat pump, empty the condenser risk of freezing
Communication problem	E08	No communication between the printed circuit board and the user interface	Check the connectors - see the wiring diagram
Level 1 antifreeze protection	E19	2° < Water temperature < 4° and Air temperature < 0°	Stop heat pump operation, empty the condenser to avoid freezing, by default the heat pump starts the filtration pump to avoid icing over
Level 2 antifreeze protection	E29	Water temperature < 2° and Air temperature < 0°	Stop heat pump operation, empty the condenser to avoid freezing, by default the heat pump starts the filtration pump and the heat pump to avoid icing over.
Fan motor fault	F031	Motor jammed or faulty connection	Check free rotation; check CN97/DC connectors; replace the motor
Fan motor fault	F051	Faulty connection	Check the DCFAN/CN97 connector; replace the motor
Exterior temperature too low	TP	Operating limit reached	Stop the heat pump



## 6. APPENDIX (continued)

---

### 6.5 Warranty

#### WARRANTY CONDITIONS

All HAYWARD products are guaranteed to be free from manufacturing or material faults for a period of two years as from the date of purchase. Any claim made under the terms of the warranty must be accompanied by a dated proof of purchase. We therefore recommend that you keep your invoice.

The HAYWARD warranty is limited to the repair or replacement, at HAYWARD's discretion, of faulty products, provided they have been used under normal conditions, as described in their user guide, and that the product has not been modified in any way and has been used only with HAYWARD components and parts. Frost and chemical damage are not covered.

No other costs (transportation, labour, etc.) are covered by the warranty.

HAYWARD cannot be held liable for any direct or indirect damage caused by the incorrect installation, connection or operation of a product.

Please contact your retailer if you want to make a claim under the terms of the warranty and request the repair or replacement of an item. No equipment returned to our factory will be accepted without our prior written agreement.

Worn parts are not covered by the warranty.

### 6.6 End of life of the device



The symbol of the crossed-out dustbin concerning the treatment and the reclamation of electrical and electronic waste means that the products must not be disposed of with household waste, bulky items or in a landfill under no circumstances.

 At the end of life, the device must undergo selective collection so that it can be recycled or reclaimed. A specific circuit for recovering this type of products is set up in the countries of the European Union and in Norway.

Contact the installer or the local representative to have this device collected, dismantled and recycled.

Retreating the refrigerant, oil and other parts has to be carried out by a qualified accredited professional in accordance with current local and national legislation.

If the product contains batteries that bear this symbol, this means that the batteries can contain harmful or polluting substances. In this case, take the batteries to a used battery collection point.

*Page left intentionally blank*



# HAYWARD<sup>®</sup>

## *FULL INVERTER*

UNIDAD DE BOMBA DE CALOR PARA PISCINAS



HP5091DT3HA	HP5111DT3HA	HP5151DT3HA	HP5181DT3HA
-------------	-------------	-------------	-------------

**Manual de Instalación e Instrucciones**

# ÍNDICE

<b>1. INSTRUCCIONES GENERALES - SEGURIDAD</b>	<b>1</b>
<b>2. CARACTERÍSTICAS TÉCNICAS</b>	<b>5</b>
2.1 Datos técnicos de la bomba de calor	5
2.2 Margen de funcionamiento	6
2.3 Dimensiones	7
<b>3. INSTALACIÓN Y CONEXIÓN</b>	<b>8</b>
3.1 Diagrama esquemático	8
3.2 Bomba de calor	8
3.3 Conexión hidráulica	10
3.4 Conexión eléctrica	11
3.5 Primer arranque	12
3.6 Ajuste del caudal de agua	14
<b>4. INTERFAZ USUARIO</b>	<b>15</b>
4.1 Presentación general	15
4.2 Ajuste de la fecha y de la hora	17
4.3 Ajuste de los temporizadores Marcha/Parada	18
4.4 Ajuste y visualización del punto de referencia	20
4.5 Apertura y bloqueo automático de la pantalla táctil	21
4.6 Ajuste del modo silencioso	22
<b>5. MANTENIMIENTO E INVIERNO</b>	<b>25</b>
5.1 Mantenimiento	25
5.2 Invierno	25
<b>6. ANEXOS</b>	<b>26</b>
6.1 Esquemas eléctricos	26
6.2 Conexiones con prioridad al calentador de bomba monofásico	28
6.3 Despiece y piezas de recambio	30
6.4 Guía de reparación	34
6.5 Garantía	37
6.6 Final de vida del aparato	37

Leer atentamente y conservar para consultar con posterioridad.

Este documento debe suministrarse al propietario de la piscina y debe ser conservado por éste en un lugar seguro.

# 1. INSTRUCCIONES GENERALES - SEGURIDAD

---

Le agradecemos la compra de esta bomba de calor de piscina Hayward. La bomba de calor Hayward FULL INVERTER ha sido diseñada según normas estrictas de fabricación para satisfacer los más altos niveles de calidad requeridos.

Las bombas de calor Hayward le ofrecerán excepcionales prestaciones a todo lo largo de su temporada de baños, adaptando la potencia, el consumo eléctrico y el nivel sonoro a la necesidad de calentamiento de su piscina gracias a la lógica de control FULL INVERTER.



***Lea atentamente las consignas de este manual antes de utilizar el aparato.***

El presente manual incluye todas las informaciones necesarias referentes a la instalación, la eliminación de los disfuncionamientos y el mantenimiento.

Lea atentamente este manual antes de abrir la unidad o de realizar operaciones de mantenimiento en la misma. En ningún caso, el fabricante del producto será responsable en caso de lesiones de un usuario o de daño de la unidad debido a eventuales errores de instalación, de eliminación de disfuncionamientos o de un mantenimiento inadecuado. Es primordial seguir en todo momento las instrucciones especificadas en este manual.

Tras leer este manual, téngalo a mano para poder utilizarlo con posterioridad.

## **Personal habilitado**

- La instalación, las conexiones eléctricas, el mantenimiento y las reparaciones del aparato deben ser efectuadas por un profesional calificado en conformidad con los textos reglamentarios y las reglas del arte vigentes en el país de instalación del aparato (cf § 3.4)  
Para cualquier intervención en el circuito frigorífico, el profesional debe ser titular de un certificado de aptitud para la manipulación de fluidos frigorígenos.  
Para Francia:
  - Instalación eléctrica de baja tensión según la NF-C 15-100.
  - Legislación sobre el manejo de fluidos frigorígenos Decreto 2007/737 y sus disposiciones de aplicación.

# 1. INSTRUCCIONES - SEGURIDAD (continuación)

## Este producto contiene gas refrigerante R32



*Este aparato contiene R32.*

*Nunca utilizar otro refrigerante que no sea el R32. Cualquier otro cuerpo gaseoso mezclado con el R32 corre el riesgo de provocar presiones anormalmente elevadas que pueden ocasionar una avería o una ruptura de tubos y lesionar personas.*

*Durante las reparaciones u operaciones de mantenimiento, emplear tubos de cobre conformes a la Norma NF EN 12375-1 y a la Directiva Europea de equipos de presión 97/23/CE.*

*Como la bomba de calor está a presión, nunca perforar los tubos ni intentar hacer una soldadura. Hay riesgo de explosión.*

*Nunca exponer el aparato a llamas, chispas ni otras fuentes de encendido. Podría explotar y ocasionar lesiones graves, incluso mortales.*

*Para la detección de fugas del fluido frigorígeno: no utilizar la lámpara haloidea ni cualquier otro detector que emplee una llama abierta. En ningún caso deberán emplearse fuentes potenciales de inflamación.*

Este producto contiene gases de efecto invernadero enmarcados dentro del protocolo de Kyoto. No libere estos gases a la atmósfera.

Valor GWP(1) : 675, Valor basado en el 4.º informe del GIEC.

Grupo de seguridad : A2L.

La cantidad de refrigerante basada en el reglamento n.º 517/2014 (F-Gas) se indica en la placa de características de la unidad.

Cualquier intervención en el circuito frigorífico deberá ser efectuado por un profesional calificado, como indicado anteriormente.

Las inspecciones periódicas de fugas de refrigerante pueden ser requeridas por la legislación europea o local. Póngase en contacto con su distribuidor local para obtener más información.

- Cuidado, los fluidos frigorígenos pueden ser inodoros.
- No perforar ni calentar la tubería, pues existe un riesgo de explosión y de graves quemaduras.
- No emplear ningún medio de aceleración del proceso de deshielo o de limpieza distinto a los recomendados por el fabricante.
- El aparato debe almacenarse en un local libre de fuentes de inflamación que funcionen en continuo (por ejemplo, fuegos abiertos, aparatos de gas o radiador eléctrico en funcionamiento).

(1) Potencial de calentamiento global

# 1. INSTRUCCIONES - SEGURIDAD (continuación)

## Condiciones de instalación

- Esta bomba de calor está destinada exclusivamente a calentar el agua de la piscina, no debiendo ser empleada para otros fines.
- No intente instalar por sí mismo este aparato.
- Si detecta cualquier defecto o situación anormal, no instale la bomba de calor y contacte inmediatamente con su revendedor.
- En caso de almacenamiento, la bomba de calor se debe almacenar en una habitación bien ventilada y con una superficie de más de  $A_{min}(m^2)$  dada por la siguiente fórmula:  $A_{min} = (M/(2,5 \times 0,22759 \times h_0))^2$   
M es la carga de refrigerante en el aparato en kg y  $h_0$  es la altura de almacenamiento. Para almacenar sobre el suelo  $h_0 = 0,6$  m.
- Este producto ha sido diseñado exclusivamente para su uso doméstico y su instalación en exterior. El aire que se escapa del producto debe poder fluir libremente, no debiendo ser empleado a otros fines, como el calentamiento o el enfriamiento de una estancia o un edificio.
- Comprobar el cable de alimentación. Si el cable de alimentación está dañado, deberá ser sustituido por el fabricante, su servicio técnico o por una persona cualificada y autorizada.
- La puesta a tierra y la unión del aparato son obligatorias. El hilo a tierra debe ser más largo que los otros hilos para prevenir riesgos de electrización en caso de arrancamiento del cable. La instalación eléctrica debe contar obligatoriamente con una protección diferencial de 30 mA (cf § 3.4).
- Verificar que el soporte previsto para la unidad está correctamente dimensionado para el peso del aparato.
- **El no seguir cualquiera de estas recomendaciones supone la anulación de la garantía.**

## Consignas para la conservación y el mantenimiento

Las operaciones de mantenimiento deben realizarse 1 vez al año con el fin de garantizar la longevidad y el buen funcionamiento de la bomba de calor.

- El mantenimiento y las diferentes operaciones deben ser realizadas con la frecuencia y en los momentos recomendados que se especifican en el presente manual.
- Utilice solamente piezas de repuesto originales.
- Comprobar el cable de alimentación. Si el cable de alimentación está dañado, deberá ser sustituido por el fabricante, su servicio técnico o por una persona cualificada y autorizada.
- Verificar la conexión a tierra del aparato y su continuidad.

# 1. INSTRUCCIONES - SEGURIDAD (continuación)

- Limpie el evaporador con un cepillo flexible o de un chorro de aire o agua (**Atención no utilizar jamás un limpiador de alta presión**).
- Verifique el buen flujo de los condensados.
- Compruebe la fijación de las conexiones hidráulicas y eléctricas
- Compruebe la estanqueidad hidráulica del condensador.
- **Un profesional autorizado** deberá comprobar la estanqueidad del circuito frigorífico con un detector de fugas.



***Antes de realizar cualquier operación de mantenimiento, la bomba de calor debe estar desconectada de cualquier fuente de corriente eléctrica. Las operaciones de mantenimiento deben ser realizadas únicamente por personal cualificado y capacitado para manipular fluidos frigorígenos.***

## Consignas para el invierno

- Poner la bomba de calor en Modo "OFF".
- Cortar la alimentación de la bomba de calor.
- Vaciar el condensador a través del desagüe para evitar cualquier riesgo de degradación. (riesgo importante de congelación).
- Cerrar la válvula "by-pass" y desatornillar las conexiones de unión entrada/salida.
- Expulse toda el agua estancada residual del condensador ayudándose con una pistola de aire.
- Obture la entrada y la salida de agua a la bomba de calor para evitar la intrusión de cuerpos extraños.
- Cubrir la bomba de calor con una funda de protección para el invierno.



***Cualquier daño ocasionado por un mal mantenimiento invernal conlleva la anulación de la garantía.***

## Condiciones de uso

Este aparato puede ser utilizado por la infancia a partir de 8 años, así como por personas con capacidades físicas, sensoriales o mentales reducidas, o desprovistos de experiencia y conocimiento, si están correctamente vigiladas o si han recibido las instrucciones sobre el uso seguro del dispositivo y conocen los riesgos a los que se exponen. La infancia no debe jugar con el aparato. La limpieza y el mantenimiento por parte del usuario no deberán ser efectuados por la infancia sin vigilancia.



## 2. CARACTERÍSTICAS TÉCNICAS

### 2.1 Datos técnicos de la bomba de calor

Modelos	FULL INVERTER	HP5091DT3HA	HP5111DT3HA	HP5151DT3HA	HP5181DT3HA
Tensión de alimentación	V	220 V-240 V ~ / monofásica / 50 Hz			
Refrigerante	/	R32			
Carga	kg	0,430	0,450	0,60	0,670
Masa en tCO <sub>2</sub> eq	/	0,29	0,30	0,41	0,45
Frecuencia de control de fuga	/	Ninguna exigencia, pero se recomienda una vez al año			
Capacidad de calentamiento Mín--Máx <sup>(a)</sup>	kW	2,46 -- 9,17	2,36 -- 11,45	3,31 -- 15,90	3,2 -- 18,15
Potencia eléctrica absorbida Mín--Máx <sup>(a)</sup>	kW	0,17 -- 1,45	0,17 -- 1,80	0,27 -- 2,84	0,22 -- 3,13
Corriente nominal de servicio Mín--Máx <sup>(a)</sup>	A	1,17 -- 6,42	1,19 -- 7,85	1,37 -- 12,35	1,45 -- 13,58
COP Máx--Mín <sup>(a)</sup>	/	14,37 -- 6,32	13,88 -- 6,35	12,26 -- 5,59	14,34 -- 5,80
Capacidad de calentamiento Mín--Máx <sup>(b)</sup>	kW	1,75 -- 7,05	1,56 -- 8,00	3,05 -- 12,40	2,86 -- 14,11
Potencia eléctrica absorbida Mín--Máx <sup>(b)</sup>	kW	0,27 -- 1,51	0,279 -- 1,74	0,42 -- 2,65	0,43 -- 2,99
COP Máx--Mín <sup>(b)</sup>	/	6,40 -- 4,65	5,60 -- 4,80	7,26 -- 4,68	6,63 -- 4,71
Corriente máxima de servicio (CMS)	A	8,40	9,50	14	15,9
Calibre del fusible	aM	10	12	16	20
Disyuntor curva D	D	10	12	16	20
Intensidad por arranque	A	< CMS			
Conexión hidráulica	mm	50 mm			
Caudal nominal de agua <sup>(a)</sup>	m <sup>3</sup> /h	4,00	5,00	6,70	7,70
Pérdida de carga máxima en el agua	kPa	3,80	4,0	6,3	10
Compresor	/	DC Inverter Panasonic		DC Inverter Mitsubishi	
Tipo	/	Rotativo doble		Rotativo doble	
Cantidad	/	1			
Resistencia de enrollado a 20°C	Ohmio	1,208		0,95	
Ventilador	/	Axial			
Cantidad		1			
Diámetro	mm	405		510	
Cantidad de aletas	/	3			
Motor	/	Inversor CD			
Cantidad	/	1			
Velocidad de rotación	rpm	400 -- 700	500 -- 850	300 -- 750	400 -- 750
Velocidad modo silencio	rpm	400	500	300	400
Nivel de presión acústica a 1 m	dB(A)	50,2	53,9	50,8	54,0
Nivel de presión acústica a 10 m	dB(A)	32,8	34,2	33,8	37,25
Dimensiones netas de la unidad (longitud-ancho-altura)	mm	1003 / 418 / 605		1048 / 437 / 768	1161 / 473 / 862
Masa	kg	44	45	66	70

(a) Aire seco 27°C - Humedad relativa 78% - Temperatura de entrada del agua 26°C.



(b) Aire seco 15°C - Humedad relativa 71% - Temperatura de entrada del agua 26°C.

## 2. CARACTERÍSTICAS TÉCNICAS (continuación)

---

### 2.2 Margen de funcionamiento

Utilizar la bomba de calor dentro de los siguientes márgenes de temperatura y de humedad para garantizar un funcionamiento seguro y eficaz.

	Modo calentamiento 	Modo enfriamiento 
Temperatura exterior	-7°C – +35°C	+7°C – +43°C
Temperatura del agua	+12°C – +32°C	+8°C – +40°C
Humedad relativa	< 80%	< 80%
Margen de reglaje del punto de referencia	+15°C – +32°C	+8°C – +32°C



***Si la temperatura o la humedad no corresponden a estas condiciones, los dispositivos de seguridad pueden activarse y la bomba de calor puede no funcionar.***



***La temperatura máxima de calentamiento está limitada a 32°C para evitar el deterioro de los revestimientos. Hayward no se hace responsable en el caso de un uso por encima de +32°C.***

## 2. CARACTERÍSTICAS TÉCNICAS (continuación)

### 2.3 Dimensiones

Modelos:

HP5091DT3HA / HP5111DT3HA / HP5151DT3HA / HP5181DT3HA

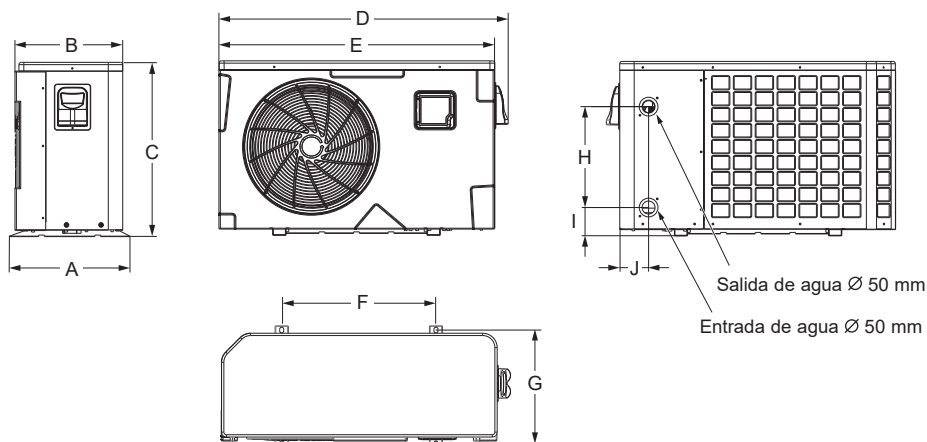

Unidad : mm

Referencia \ Modelo	HP5091DT3HA / HP5111DT3HA	HP5151DT3HA	HP5181DT3HA
<b>A</b>	418	436,5	473
<b>B</b>	374	418	451,5
<b>C</b>	604,5	767,5	862
<b>D</b>	1003	1047,5	1160,5
<b>E</b>	956	1002	1115
<b>F</b>	535	615	790
<b>G</b>	394,5	410	447
<b>H</b>	350	350	466
<b>I</b>	97,7	101,2	97,6
<b>J</b>	99,2	106,5	113,5

## 3. INSTALACIÓN Y CONEXIÓN

### 3.1 Diagrama esquemático

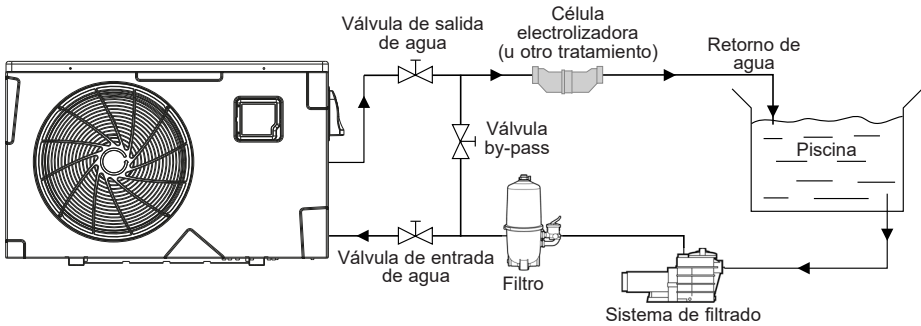

Nota: La bomba de calor se suministra sin ningún equipo de tratamiento o filtración. Los elementos que aparecen en el esquema son las piezas que deberá proporcionar el instalador.

### 3.2 Bomba de calor



**Colocar la bomba de calor en el exterior y fuera de cualquier sala técnica cerrado.**

**Elegir una ubicación preferentemente soleada y protegida de los vientos dominantes.**

**El aparato debe ser perfectamente accesible para los trabajos de instalación y de mantenimiento ulteriores.**

**Colocar en una zona resguarda, las distancias mínimas que a continuación se prescriben deben ser respetadas a fin de evitar cualquier riesgo de recirculación del aire y de una degradación del rendimiento global de la bomba de calor.**

Unidad: mm

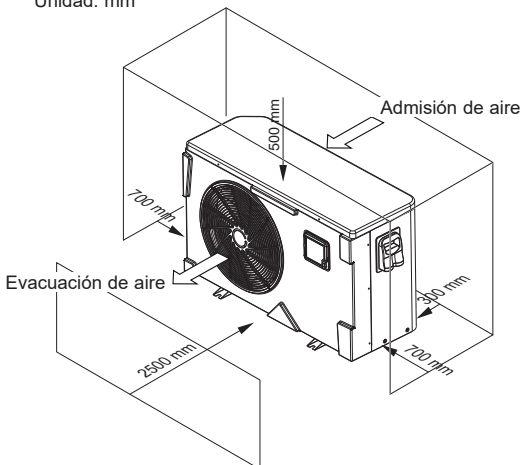

### 3. INSTALACIÓN Y CONEXIÓN (continuación)



**No colocar el aparato directamente en el suelo pues podría provocar perturbaciones.**

**Deberá privilegiarse una colocación en el suelo sobre bloques antivibraciones.**

**No deberá emplearse un soporte mural en condiciones capaces de transmitir las vibraciones.**

**No instalar la bomba de calor sobre un soporte que pueda amplificar las vibraciones de la unidad.**

**No instalar la bomba de calor en un lugar que pueda amplificar su nivel sonoro o en un lugar donde el ruido de la unidad pueda molestar a los vecinos.**

**No emplear adhesivos: estos no son considerados medios de fijación fiables.**

**Preferiblemente instale la bomba de calor sobre una superficie de hormigón plana y aislada o una silla de fijación prevista a tal fin y monte la bomba de calor sobre los silentblocks suministrados (los tornillos y arandelas se suministran).**

**Fijar el aparato respetando el apriete indicado para evitar cualquier riesgo de accidente o daño a los materiales y las personas.**

**Otra posibilidad: instalar la bomba de calor sobre pies de caucho utilizando la tornillería adaptada (no suministrada).**

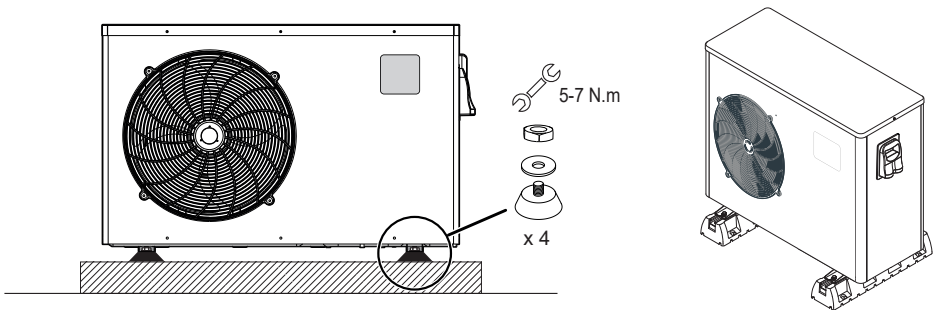

**Distancia máxima de instalación entre la bomba de calor y la piscina 15 metros.**

**Longitud total de ida-vuelta de las canalizaciones hidráulicas 30 metros.**

**Aislar las canalizaciones hidráulicas de superficie y enterradas.**

**La bomba de calor debe instalarse a una distancia mínima de la piscina en cumplimiento de la NF C 15-100 (es decir a 3,5 m de la piscina para Francia) o según las normas de instalación vigentes en el resto de países.**

**No instalar la bomba de calor cerca de una fuente de calor.**

**En caso de instalación en regiones nevadas, se recomienda poner la máquina a resguardo para evitar una acumulación de nieve sobre el evaporador.**

## 3. INSTALACIÓN Y CONEXIÓN (continuación)

---

### 3.3 Conexión hidráulica

La bomba de calor se suministra con dos conexiones de unión de 50 mm de diámetro. Utilice un tubo de PVC para la canalización hidráulica Ø 50 mm. Conecte la entrada de agua de la bomba de calor al conducto proveniente del grupo de filtración, tras esto conecte la salida de agua de la bomba de calor al conducto de agua que va a la piscina (cf esquema de abajo).

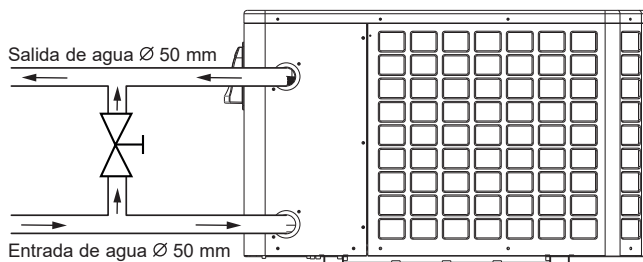

Instale una válvula "by-pass" entre la entrada y la salida de la bomba de calor.



***Si se utiliza un distribuidor automático o un electrolizador, se debe instalar obligatoriamente después de la bomba de calor con el fin de proteger el condensador de titanio de una concentración demasiado grande de producto químico.***



***Se ruega instale la válvula by-pass y las conexiones de unión suministradas al nivel de la entrada y la salida de agua de la unidad, con el fin de simplificar la purga durante el periodo invernal y de facilitar el acceso o el desmontaje para el mantenimiento.***

### 3. INSTALACIÓN Y CONEXIÓN (continuación)

#### 3.4 Conexión eléctrica



**La instalación eléctrica y el cableado de este equipo debe cumplir con la normativa de instalación local en vigor.**

F	NF C15-100	GB	BS7671:1992
D	DIN VDE 0100-702	EW	EVHS-HD 384-7-702
A	ÖVE 8001-4-702	H	MSZ 2364-702/1994/MSZ 10-553 1/1990
E	UNE 20460-7-702 1993, RECBT ITC-BT-31 2002	M	MSA HD 384-7-702.S2
IRL	Wiring Rules + IS HD 384-7-702	PL	PN-IEC 60364-7-702:1999
I	CEI 64-8/7	CZ	CSN 33 2000 7-702
LUX	384-7.702 S2	SK	STN 33 2000-7-702
NL	NEN 1010-7-702	SLO	SIST HD 384-7-702.S2
P	RSIUEE	TR	TS IEC 60364-7-702



**Compruebe que la alimentación eléctrica disponible y la frecuencia de la red corresponden con la corriente de funcionamiento requerida, teniendo en consideración el emplazamiento específico del aparato y la corriente necesaria para alimentar cualquier otro aparato que esté conectado al mismo circuito.**

**HP5091DT3HA / HP5111DT3HA / HP5151DT3HA / HP5181DT3HA  
230V ~ +/- 10 % 50 Hz 1 Fase**

**Observe el esquema de cableado correspondiente en el anexo.  
La caja de conexiones se encuentra en el lado derecho de la unidad.  
Hay tres conexiones destinadas a la alimentación eléctrica y dos para el control del sistema de filtrado (servomecanismo).**

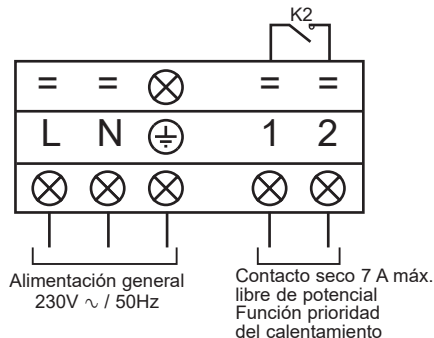

### 3. INSTALACIÓN Y CONEXIÓN (continuación)

---



**No utilizar nunca una toma de corriente para la alimentación. La línea de alimentación eléctrica debe estar dotada, de manera apropiada, de un dispositivo de protección omnipolar de tipo disyuntor curva D, así como de un disyuntor diferencial de protección 30 mA (ver tabla a continuación).**

Modelos		HP5091DT3HA	HP5111DT3HA	HP5151DT3HA	HP5181DT3HA
Alimentación eléctrica	V/Ph/Hz	230V~ 50Hz	230V~ 50Hz	230V~ 50Hz	230V~ 50Hz
Disyuntor curva D	A	8 D	10 D	16 D	20 D
Sección de cable	mm <sup>2</sup>	3G 2,5	3G 2,5	3G 2,5	3G 4



**Use un cable de alimentación de tipo RO2V / R2V o equivalente.**



**Las secciones de cable indicadas se corresponden a una longitud máxima de 25 m. Sin embargo, deben comprobarse y adaptarse en función de las condiciones de instalación.**



**Tenga siempre cuidado de detener la alimentación principal antes de abrir la caja de control eléctrico.**

**Después del corte de la alimentación, esperar 10 minutos antes de acceder a las partes activas internas del equipo (energía almacenada en los condensadores).**

#### 3.5 Primer arranque

Procedimiento de arranque - una vez que se ha terminado la instalación, siga y respete las siguientes etapas:

- 1) Gire los ventiladores con la mano para comprobar que pueden girar libremente y que la hélice está correctamente fijada al árbol del motor.
- 2) Asegúrese de que la unidad está conectada correctamente a la alimentación principal (ver el esquema de cableado en el anexo).
- 3) Active el sistema de filtrado.
- 4) Verifique que todas las válvulas de agua están abiertas y que el agua circula hacia la unidad antes de pasar al modo de calentamiento o enfriamiento.
- 5) Verifique que la acometida de purga de condensados está fijada correctamente y no presenta ninguna obstrucción.
- 6) Activar la alimentación eléctrica destinada a la unidad, después presione



### 3. INSTALACIÓN Y CONEXIÓN (continuación)

---

el botón de Marcha/Parada  sobre el panel de control.

- 7) Cerciórese de que no se visualicen los símbolos de alarma o de bloqueo. Dado el caso, ver la guía de reparación (ver § 6.4).
- 8) Fije el caudal de agua con la ayuda de la válvula by-pass (ver § 3.6 y 2.1), tal y como se prevee respectivamente para cada modelo de manera que obtenga una diferencia de temperatura Entrada/ Salida de 2°C.
- 9) Tras estar funcionando unos cuantos minutos, verifique que el aire sale de la unidad y se enfría (entre 5 y 10°).
- 10) Estando la unidad en servicio, desactive el sistema de filtrado. La unidad debe pararse automáticamente y mostrar el código de error E03.
- 11) Haga funcionar la unidad y la bomba de la piscina durante 24 horas seguidas, hasta que se alcance la temperatura del agua deseada. Cuando la temperatura de entrada del agua alcance el valor de referencia, la unidad se para. Se pone en funcionamiento de nuevo automáticamente (siempre que la bomba de la piscina esté en servicio) si la temperatura desciende menos de 0,5°C por debajo de la temperatura de referencia.

**Controlador del caudal** - La unidad está dotada de un controlador de caudal que activa la bomba de calor mientras el sistema de filtrado de la piscina está en servicio y la desactiva cuando el sistema de filtrado está fuera de servicio. Por falta de agua, el código de alarma E03 aparece en el reguador (Ver § 6.4).

**Temporización** - la unidad integra una temporización de 3 minutos, que tiene por objeto proteger los componentes del circuito de control, eliminar cualquier inestabilidad en el arranque y cualquier interferencia del contactor. Por medio de esta temporización, la unidad arranca de nuevo automáticamente unos 3 minutos después de que se produzca un corte del circuito de control. Incluso un corte de corriente de corta duración activa la temporización de arranque.

### 3. INSTALACIÓN Y CONEXIÓN (continuación)

---

#### 3.6 Ajuste del caudal de agua

Con las válvulas de entrada y salida de agua abiertas, ajustar la válvula "by-pass" de forma que se obtenga una diferencia de 2°C entre la temperatura de entrada y de la salida del agua (ver el esquema eléctrico § 3.1). Puede verificar el ajuste visualizando las temperaturas de entrada/salida directamente sobre el panel de control.



Nota: La apertura de la válvula "by-pass" genera un caudal menor, lo cual conlleva un aumento de  $\Delta T$ .

El cierre de la válvula "by-pass" genera un caudal mayor, lo cual conlleva una disminución de  $\Delta T$ .

# 4. INTERFAZ USUARIO

## 4.1 Presentación general

La bomba de calor está equipada con un panel de control digital con pantalla táctil, el cual ha sido previamente conectado eléctricamente y programado en fábrica para funcionar en modo calentamiento.

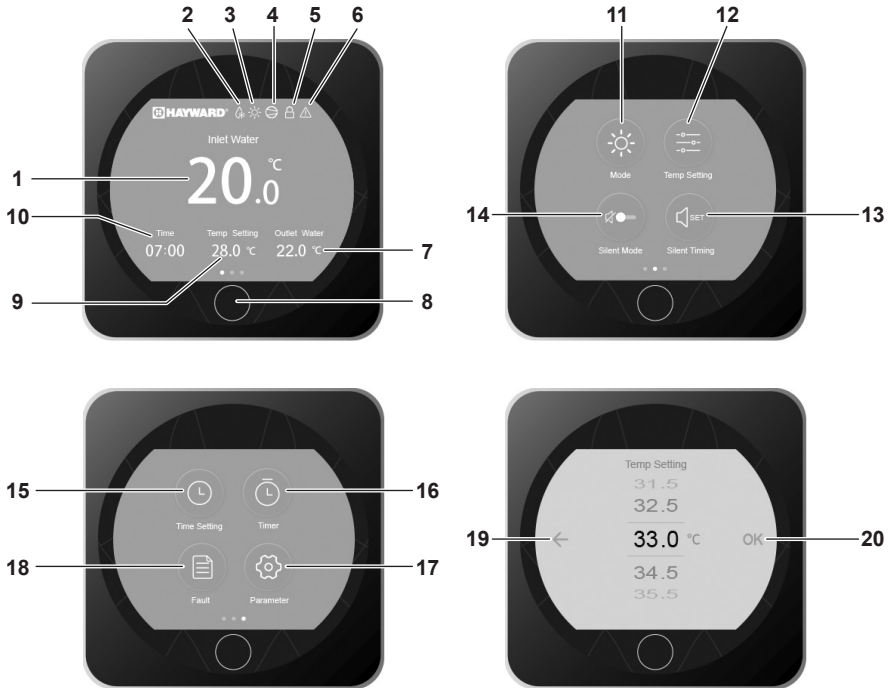

### Leyenda

1	Temperatura de entrada del agua
2	Modo deshielo
3	Modo de funcionamiento
4	Indicador luminoso de marcha del compresor
5	Bloqueo de la pantalla
6	Alarma
7	Temperatura de salida del agua
8	Marcha/Parada/Retorno
9	Temperatura de consigna
10	Tiempo

11	Selección del modo de funcionamiento
12	Regulación del punto de consigna
13	Ajuste del temporizador en modo silencioso
14	Activación del modo silencio
15	Regulación de la fecha y la hora
16	Regulación Temporizadores Marcha/Parada
17	Acceso a los parámetros avanzados
18	Acceso a la lista de defectos
19	Retorno (sin validación)
20	Validación

## 4. INTERFAZ USUARIO (continuación)

### Modo OFF/PARADA

Cuando la bomba de calor está parada (en espera), aparece la inscripción OFF, como se indica en la pantalla.

La pantalla negra indica que la bomba de calor está parada, es posible ajustar los parámetros en este modo.



### Modo ON/MARCHA

Cuando la bomba de calor está en funcionamiento o en regulación (se alcanza el punto de consigna), la pantalla pasa a azul.





Para pasar del modo OFF al modo ON y viceversa, pulsar el botón .

## 4. INTERFAZ USUARIO (continuación)

### 4.2 Ajuste de la fecha y de la hora

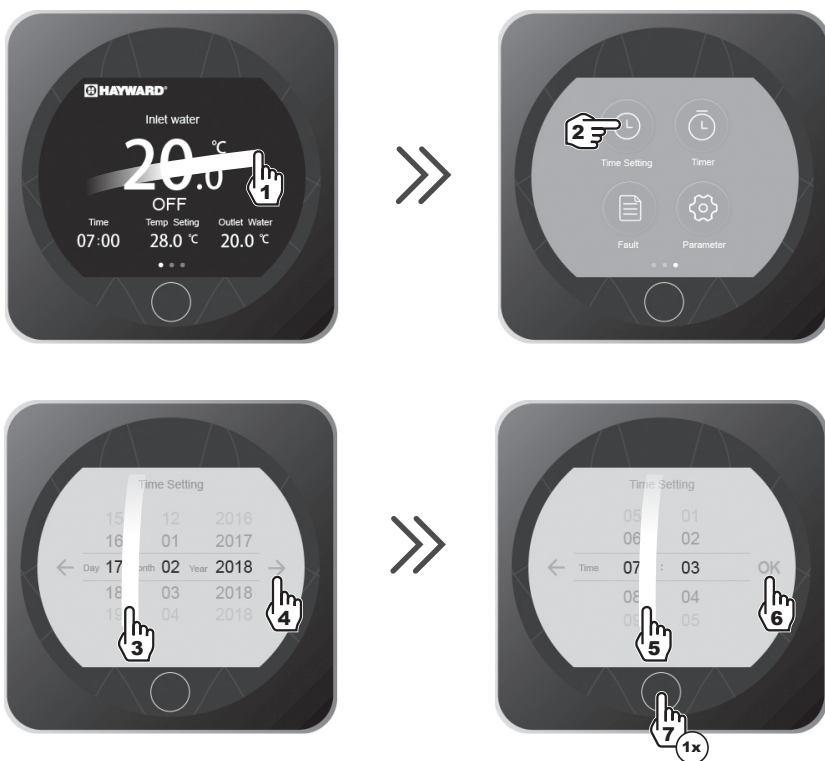
El ajuste de la fecha y de la hora se puede hacer indistintamente en modo ON u OFF.



- Pulsar 1 veces  para volver a la pantalla principal.

## 4. INTERFAZ USUARIO (continuación)

### 4.3 Ajuste de los temporizadores Marcha/Parada

El ajuste de esta función será necesario cuando usted desee hacer funcionar su bomba de calor durante un periodo de tiempo más corto que el determinado por el reloj de filtración. De esta forma podrá programar un arranque retardado y una parada anticipada o simplemente prohibir un periodo horario de funcionamiento (por ejemplo la noche)..

Tiene la posibilidad de programar un temporizador de Marcha y un temporizador de Parada. El paso de ajuste es «de hora en hora».



## 4. INTERFAZ USUARIO (continuación)

---



**Resaltado en azul = Activado**  
**Gris = Desactivado**

- Pulsar 2 veces  para volver a la pantalla principal.

## 4. INTERFAZ USUARIO (continuación)

### 4.4 Ajuste y visualización del punto de referencia

El ajuste del punto de consigna se efectúa indistintamente en modo ON o en modo OFF con una precisión de 0,5°C.



- Pulsar 1 vez  para volver a la pantalla principal.



**Se recomienda no sobrepasar jamás la temperatura de 30°C para evitar la alteración de los liners.**



## 4. INTERFAZ USUARIO (continuación)

### 4.5 Apertura y bloqueo automático de la pantalla táctil

El bloqueo y desbloqueo de la pantalla se pueden hacer indistintamente en modo ON o en modo OFF.



Bloqueo activado



Bloqueo desactivado

## 4. INTERFAZ USUARIO (continuación)

### 4.6 Ajuste del modo silencioso

El modo silencioso permite usar la bomba de calor en modo ahorro y de forma muy silenciosa cuando las necesidades de calentamiento son bajas (para mantener la temperatura de la piscina o en caso de necesitar un funcionamiento ultrasilencioso).

Esta función se puede Activar / Desactivar manualmente o con un temporizador.

#### Activación / Desactivación



Modo silencio desactivado



Modo silencioso activado



- Pulsar 1 vez  para volver a la pantalla principal.

## 4. INTERFAZ USUARIO (continuación)

---

### Ajuste del temporizador del modo SILENCIO



## 4. INTERFAZ USUARIO (continuación)

---



- Pulsar 2 veces  para volver a la pantalla principal.



**El paso de ajuste es «de hora en hora».**

**Una vez que el temporizador esté activado, permanecerá activo los 7 días de la semana.**

## 5. MANTENIMIENTO E INVIERNO

---

### 5.1 Mantenimiento

Estas operaciones de mantenimiento deben realizarse 1 vez al año con el fin de garantizar la longevidad y el buen funcionamiento de la bomba de calor.

- El mantenimiento y las reparaciones del aparato deben ser efectuadas por un profesional calificado en conformidad con los textos reglamentarios y las reglas del arte vigentes en el país de instalación del aparato (cf § 3.4) Para cualquier intervención en el circuito frigorífico, el profesional debe ser titular de un certificado de aptitud para la manipulación de fluidos frigorígenos.
- Comprobar el cable de alimentación. Si el cable de alimentación está dañado, deberá ser sustituido por el fabricante, su servicio técnico o por una persona cualificada y autorizada.
- Verificar la conexión a tierra del aparato y su continuidad.
- Limpie el evaporador con un cepillo flexible o de un chorro de aire o agua (**Atención no utilizar jamás un limpiador de alta presión**).
- Verifique el buen flujo de los condensados.
- Compruebe la fijación de las conexiones hidráulicas y eléctricas
- Compruebe la estanqueidad hidráulica del condensador.
- **Un profesional autorizado** deberá comprobar la estanqueidad del circuito frigorífico con un detector de fugas.



**Antes de realizar cualquier operación de mantenimiento, la bomba de calor debe estar desconectada de cualquier fuente de corriente eléctrica. Las operaciones de mantenimiento deben ser realizadas únicamente por personal cualificado y capacitado para manipular fluidos frigorígenos.**

### 5.2 Invierno

- Poner la bomba de calor en Modo "OFF".
- Cortar la alimentación de la bomba de calor.
- Vaciar el condensador a través del desagüe para evitar cualquier riesgo de degradación. (riesgo importante de congelación).
- Cerrar la válvula "by-pass" y desatornillar las conexiones de unión entrada/salida.
- Expulse toda el agua estancada residual del condensador ayudándose con una pistola de aire.
- Obture la entrada y la salida de agua a la bomba de calor para evitar la intrusión de cuerpos extraños.
- Cubrir la bomba de calor con una funda de protección para el invierno.



**Cualquier daño ocasionado por un mal mantenimiento invernal conlleva la anulación de la garantía.**

# 6. ANEXOS

## 6.1 Esquemas eléctricos

### HP5091DT3HA / HP5111DT3HA

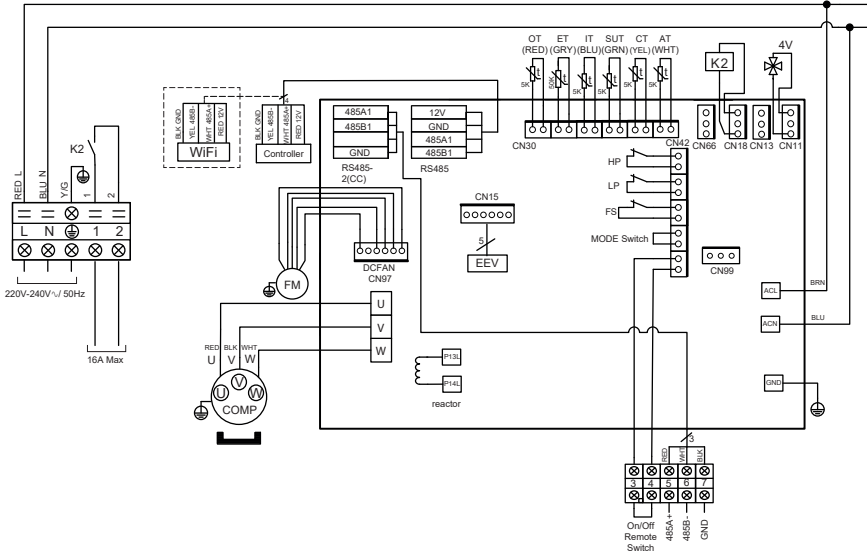

#### LEYENDA

- |   |  |
|---|--|
| <b>AT</b> : Sonda de temperatura de aire            | <b>LP</b> : Presostato baja presión                |
| <b>COMP</b> : Compresor                             | <b>OT</b> : Onda de temperatura de entrada de agua |
| <b>CT</b> : Sonda de temperatura evaporador         | <b>SUT</b> : Sonda de temperatura de aspiración    |
| <b>EEV</b> : Descompresor electrónico               | <b>4V</b> : Válvula 4 vías                         |
| <b>FM</b> : Motor ventilador                        | <b>K2</b> : Contacto seco libre de 16 A máx.       |
| <b>FS</b> : Detector de presencia de agua           | <b>ET</b> : Sonda de temperatura de descarga       |
| <b>HP</b> : Presostato alta presión                 | <b>---</b> : Opción                                |
| <b>IT</b> : Sonda de temperatura de entrada de agua |  |

# 6. ANEXOS (continuación)

## HP5151DT3HA / HP5181DT3HA

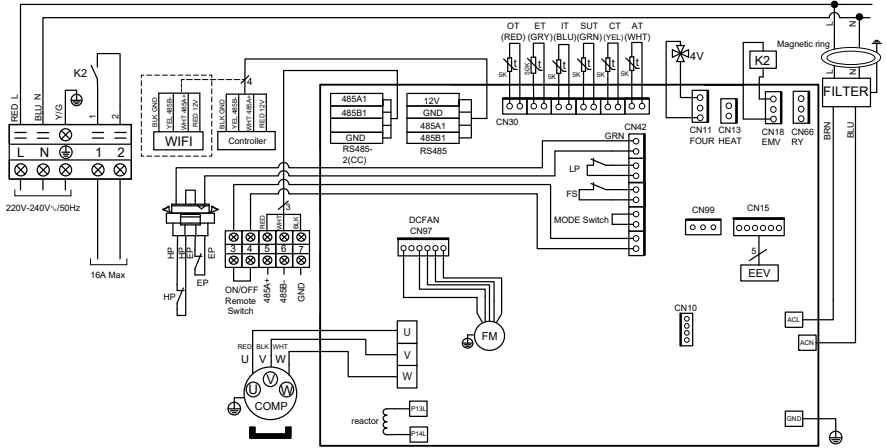

### LEYENDA

- |   |  |
|---|--|
| <b>AT</b> : Sonda de temperatura de aire            | <b>LP</b> : Presostato baja presión                |
| <b>COMP</b> : Compresor                             | <b>OT</b> : Onda de temperatura de entrada de agua |
| <b>CT</b> : Sonda de temperatura evaporador         | <b>SUT</b> : Sonda de temperatura de aspiración    |
| <b>EEV</b> : Descompresor electrónico               | <b>4V</b> : Válvula 4 vías                         |
| <b>FM</b> : Motor ventilador                        | <b>K2</b> : Contacto seco libre de 16 a máx.       |
| <b>FS</b> : Detector de presencia de agua           | <b>ET</b> : Sonda de temperatura de descarga       |
| <b>HP</b> : Presostato alta presión                 | <b>[Dashed Box]</b> : Opción                       |
| <b>IT</b> : Sonda de temperatura de entrada de agua |  |

## 6. ANEXOS (continuación)

### 6.2 Conexiones con prioridad al calentador de bomba monofásico

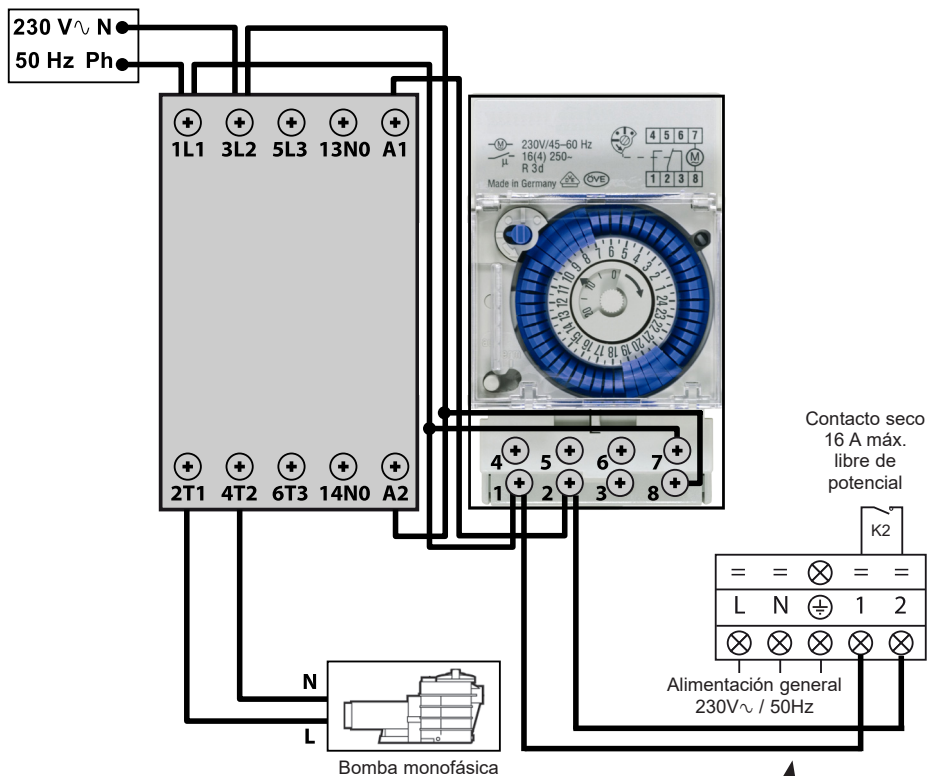

Los bornes 1 et 2 suministran un contacto seco (libre de potencial), sin polaridad de 230 V $\sim$  / 50 Hz.

Conecte los cables a los bornes 1 y 2 respetando el esquema de cableado que se indica a continuación para que la bomba de filtración funcione por ciclos de 2 min cada hora en caso de que la temperatura de la piscina sea inferior al punto de consigna.

 No conecte nunca la alimentación de la bomba de filtración directamente a los bornes 1 y 2.





---

*Página en blanco intencionalmente*

## 6. ANEXOS (continuación)

### 6.3 Despiece y piezas de recambio

HP5091DT3HA / HP5111DT3HA / HP5151DT3HA / HP5181DT3HA

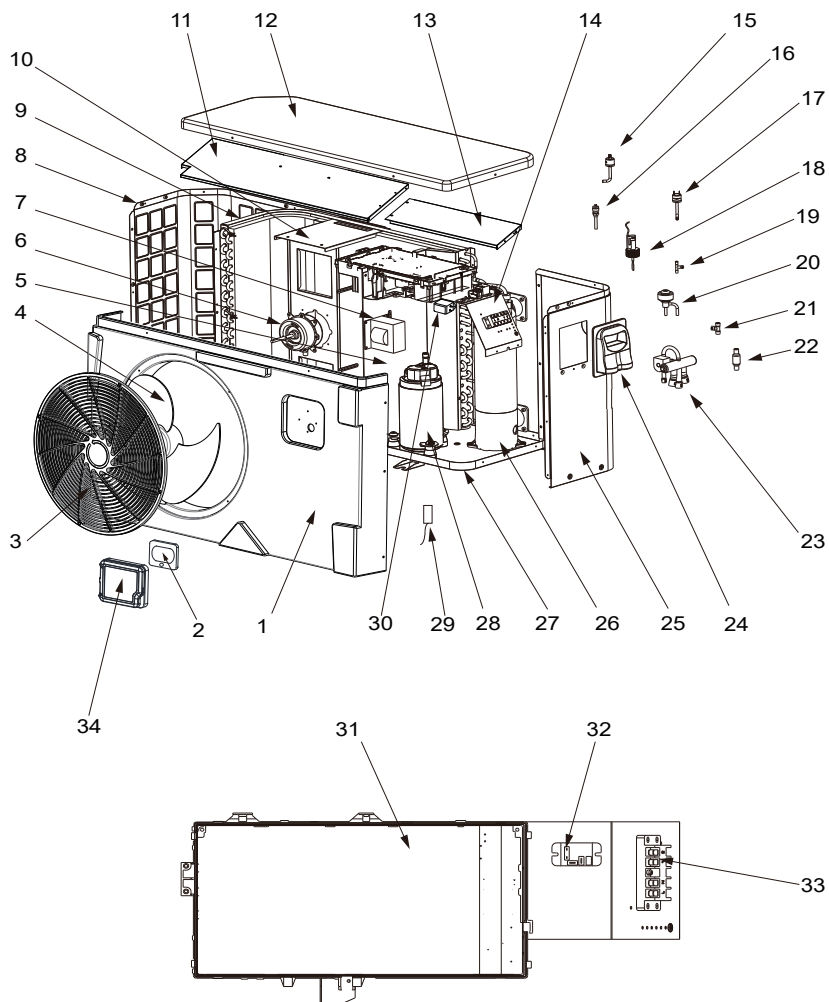

## 6. ANEXOS (continuación)

Rep	Designación	Ref.	HP5091DT3HA	HP5111DT3HA	HP5151DT3HA	HP5181DT3HA
1	Panel delantero	HWX80900843	✓	✓	n/a	n/a
		HWX80900844	n/a	n/a	✓	n/a
		HWX80900850	n/a	n/a	n/a	✓
2	Regulador LED	HWX72200070	✓	✓	✓	✓
3	Rejilla de protección del ventilador	HWX80900375	✓	✓	✓	n/a
		HWX20000220369	n/a	n/a	n/a	✓
4	Hélice ventilador	HWX301030000006	✓	✓	n/a	n/a
		HWX301030000001	n/a	n/a	✓	✓
5	/	/	/	/	/	/
6	Motor ventilador CC	HWX80200018	✓	✓	n/a	n/a
		HWX20000330132	n/a	n/a	✓	✓
7	Bobina 16 A 50 Hz 5 mH	HWX82500020	✓	✓	n/a	n/a
	Bobina 20 A 50 Hz 5.2 mH	HWX82500021	n/a	n/a	✓	✓
8	Panel de la izquierda	HWX80702123	✓	✓	n/a	n/a
		HWX80700244	n/a	n/a	✓	n/a
		HWX80702268	n/a	n/a	n/a	✓
9	Evaporador de aleta	HWX80600042	✓	n/a	n/a	n/a
		HWX80600043	n/a	✓	n/a	n/a
		HWX80600044	n/a	n/a	✓	n/a
		HWX80600078	n/a	n/a	n/a	✓
10	Soporte del motor	HWX80700218	✓	✓	n/a	n/a
		HWX80700248	n/a	n/a	✓	n/a
		HWX80700329	n/a	n/a	n/a	✓
11	/	/	/	/	/	/
12	Panel superior	HWX80900055	✓	✓	n/a	n/a
		HWX301090200806	n/a	n/a	✓	n/a
		HWX80900076	n/a	n/a	n/a	✓
13	/	/	/	/	/	/
14	/	/	/	/	/	/
15	Presostato baja presión NO 0.30 MPa / 0.15 MPa	HWX20000360157	✓	✓	✓	✓
16	Toma de presión 40 mm-1/2"	HWX20000140150	✓	✓	✓	✓
17	Presostato de alta presión NC 3.2 MPa/4.4 MPa	HWX20013605	✓	✓	✓	✓
18	Detector del caudal	HWX83000068	✓	✓	✓	✓
19	Conector en T Ø 6.5-2 x Ø 6.5(T) x 0.75	HWX20001460	✓	✓	✓	✓
20	Descompresor electrónico	HWX81000011	✓	✓	n/a	n/a
		HWX81000013	n/a	n/a	✓	✓
21	Conector en T Ø 9.52-2 x Ø 6.35(T) x 1.0	HWX304030000002	✓	✓	✓	✓
22	Filtro Ø 9.7-Ø 9.7 (Ø19)	HWX20000140178	✓	✓	n/a	n/a
	Filtro Ø 9.7-Ø 9.7 (Ø28)	HWX20041444	n/a	n/a	✓	✓
23	Válvula 4 vías	HWX20041437	✓	✓	✓	✓
24	Trampilla de acceso eléctrico	HWX320922029	✓	✓	✓	✓
		HWX80700580	✓	✓	n/a	n/a
25	Panel derecho	HWX80700878	n/a	n/a	✓	n/a
		HWX80700581	n/a	n/a	n/a	✓
		HWX72300013	✓	n/a	n/a	n/a
26	Condensador de titanio/PVC	HWX72300014	n/a	✓	n/a	n/a
		HWX72300010	n/a	n/a	✓	n/a
		HWX72300024	n/a	n/a	n/a	✓
27	/	/	/	/	/	/
28	Compresor	HWX80100108	✓	✓	n/a	n/a
		HWX80100046	n/a	n/a	✓	✓

## 6. ANEXOS (continuación)

HP5091DT3HA / HP5111DT3HA / HP5151DT3HA / HP5181DT3HA

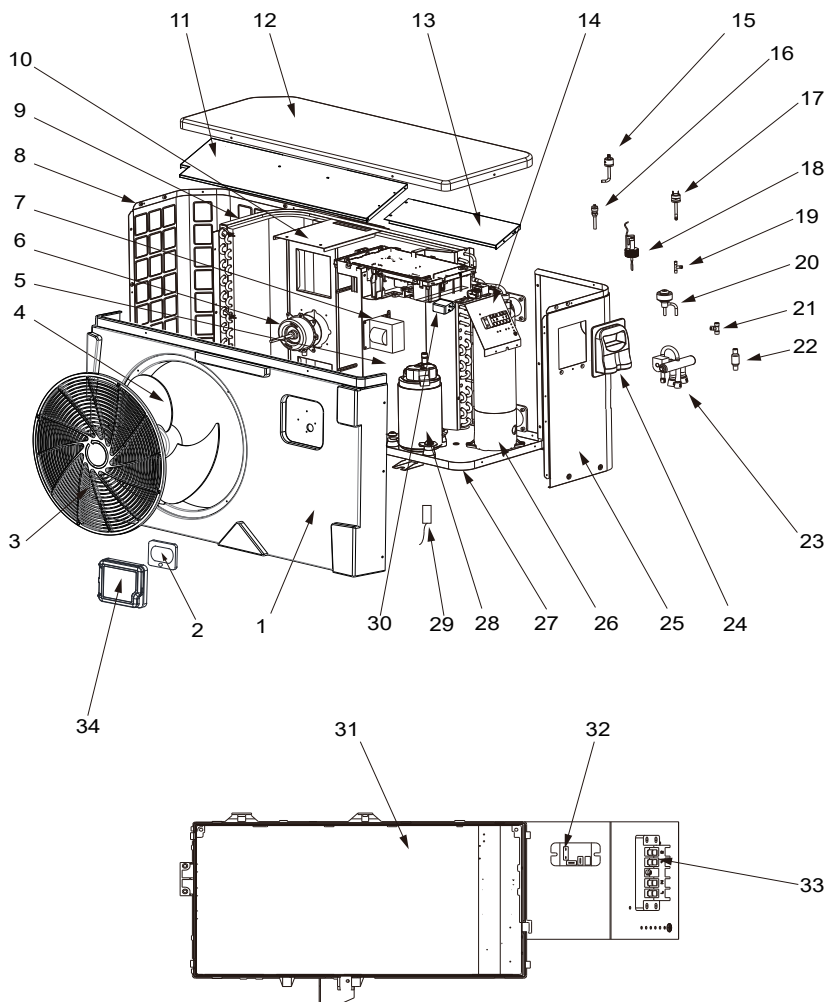

## 6. ANEXOS (continuación)

Rep	Designación	Ref.	HP5091DT3HA	HP5111DT3HA	HP5151DT3HA	HP5181DT3HA
29	Sonda de aspiración compresor 5 k - 560 mm	HWX83000044	✓	✓	n/a	n/a
	Sonda de aspiración compresor 5 k - 760 mm	HWX83000053	n/a	n/a	✓	✓
	Sonda de temperatura de aire 5 k - 350 mm	HWX83000049	✓	✓	✓	✓
	Sonda de salida de agua 5 k - 410 mm	HWX83000050	✓	✓	✓	✓
	Sonda de entrada de agua 5 k - 850 mm	HWX83000052	✓	✓	✓	n/a
	Sonda de entrada de agua 5 k - 980 mm	HWX83000055	n/a	n/a	n/a	✓
	Sonda de descarga compresor 50 k - 660 mm	HWX83000026	✓	✓	✓	✓
	Sonda de descongelación 5 k - 680 mm	HWX83000051	✓	✓	n/a	n/a
	Sonda de descongelación 5 k - 1040 mm	HWX83000045	✓	✓	✓	✓
30	Filtro EMC	HWX20003257	n/a	n/a	✓	✓
31	Tarjeta electrónica Driver	HWX72200168AP3	✓	n/a	n/a	n/a
		HWX72200168AP4	n/a	✓	n/a	n/a
		HWX72200167AP5	n/a	n/a	✓	n/a
		HWX72200167AP6	n/a	n/a	n/a	✓
32	Relé K2	HWX20000360297	✓	✓	✓	✓
33	Borna L-N-GND -5 conexiones 4 mm <sup>2</sup>	HWX40003901	✓	✓	✓	✓
34	Puerta de protección	HWX80900321	✓	✓	✓	✓

## 6. ANEXOS (continuación)

### 6.4 Guía de reparación





**Algunas operaciones deben ser realizadas por un técnico habilitado.**

En caso de defecto en la bomba de calor, aparece el símbolo  en el ángulo superior izquierdo de la pantalla.

Consulte la tabla siguiente.



**Después de resolver el problema y de haberse solucionado automáticamente, desaparece el triángulo.**

- Para borrar la lista de errores, pulsar .
- Pulsar 2 veces  para volver a la pantalla principal.

## 6. ANEXOS (continuación)

Fallo	Códigos de error	Descripción	Solución
Fallo de la sonda de entrada de agua	P01	El sensor está abierto o presenta un cortocircuito.	Verificar la conéctica CN21/RES1 en la tarjeta y el conector prolongación o reemplazar el captador
Fallo de la sonda de salida de agua	P02		Verificar la conéctica N22/RES2 en la tarjeta y el conector prolongación o reemplazar el captador
Fallo de la sonda de temperatura exterior	P04		Verificar la conéctica CN12/PH en la tarjeta y el conector prolongación o reemplazar el captador
Fallo de la sonda de descongelación	P05		Verificar la conéctica CN8/OPT en la tarjeta y el conector prolongación o reemplazar el captador
Fallo de la sonda de aspiración del compresor	P07		Verificar la conéctica CN7/OAT en la tarjeta y el conector prolongación o reemplazar el captador
Fallo de la sonda de recirculación del compresor	P081		Verificar la conéctica CN9/OHT en la tarjeta y el conector prolongación o reemplazar el captador
Protección alta presión	E01	El sensor está abierto o presenta un cortocircuito.	<p>Verificar la conéctica CN30/HP en la tarjeta o sustituir el sensor</p> <p>Comprobar el caudal de agua</p> <p>Comprobar el detector del flujo de agua</p> <p>Comprobar la apertura de las válvulas</p> <p>Comprobar el by-pass</p> <p>Comprobar el estado de suciedad del evaporador</p> <p>Temperatura del agua demasiado caliente</p> <p>En caso de problema de incondensables tras un mantenimiento, vaciar y eliminar la humedad del circuito frigorífico</p> <p>Carga de fluido demasiado importante, retirar fluido en una botella de líquido</p>
Protección baja presión	E02	El sensor está abierto o presenta un cortocircuito.	<p>Comprobar la conexión AI/DI03 en la tarjeta o sustituir el sensor</p> <p>Fuga importante de fluido frigorígeno, buscar la fuga con el detector</p> <p>Caudal de aire demasiado bajo, comprobar la velocidad de rotación del ventilador</p> <p>Comprobar el estado de suciedad del evaporador, limpiar la superficie</p>
Fallo del detector de caudal	E03	El sensor está abierto o presenta un cortocircuito.	<p>Comprobar la conexión AI/DI02 en la tarjeta o sustituir el sensor</p> <p>Falta de agua, comprobar el funcionamiento de la bomba de filtración</p> <p>Comprobar la apertura de las válvulas de parada</p> <p>Comprobar el ajuste del by-pass</p>

## 6. ANEXOS (continuación)

Fallo	Códigos de error	Descripción	Solución
Diferencia de temperatura Entrada/ Salida > 13 °C	E06	Aplicable en modo frío solamente	Falta de agua, comprobar el funcionamiento de la bomba de filtración
			Comprobar la apertura de las válvulas de parada
			Comprobar el ajuste del by-pass
Protección anticongelante Modo frío	E07	Temperatura de salida del agua < a 4 °C	Detener la bomba de calor, vaciar el condensador de riesgo de heladas
Problema de comunicación	E08	No hay comunicación entre la tarjeta electrónica y la interfaz usuario	Verificar las conexiones y la conéctica - ver esquema eléctrico
Protección anticongelante de nivel 1	E19	2° < temperatura del agua < 4° y temperatura del aire < 0°	Detener el funcionamiento de la bomba de calor, vaciar el condensador para evitar las heladas. De forma predeterminada, la bomba de calor activará la bomba de filtración y la bomba de calor para evitar la formación de hielo.
Protección anticongelante de nivel 2	E29	Temperatura del agua < 2° y temperatura del aire < 0°	Detener el funcionamiento de la bomba de calor, vaciar el condensador para evitar las heladas. De forma predeterminada, la bomba de calor activará la bomba de filtración y la bomba de calor para evitar la formación de hielo.
Defecto del motor del ventilador	F031	Motor bloqueado o defecto de conexión	Verificar la rotación libre y la conéctica CN97/DCFan, reemplazar el motor
Defecto del motor del ventilador	F051	Defecto de conexión	Verificar la conéctica DCFAN/CN97, reemplazar el motor
Temperatura exterior demasiado baja	TP	Límite de funcionamiento alcanzado	Parar la bomba de calor



## 6. ANEXOS (continuación)

---

### 6.5 Garantía

#### CONDICIONES DE GARANTÍA

Todos los productos HAYWARD están garantizados contra defectos de fabricación y material durante dos años a partir de la fecha de compra. Toda reclamación de garantía debe ir acompañada de una prueba de compra que justifique la fecha. A tal efecto, asegúrese de conservar su factura.

La garantía de HAYWARD se limita a la reparación o sustitución, a elección de HAYWARD, de los productos defectuosos, siempre que se hayan usado en condiciones normales, conforme a las recomendaciones e instrucciones del manual de uso, que no hayan sido objeto de modificación alguna y se hayan utilizado únicamente con componentes y piezas de HAYWARD. Los daños provocados por congelación y agentes químicos no están cubiertos por la garantía.

Todos los demás gastos (transporte, mano de obra, etc.) quedan excluidos de la garantía.

HAYWARD declina toda responsabilidad derivada de daños directos o indirectos causados por una instalación, una conexión o un uso incorrecto del producto.

Para usar la garantía y solicitar la reparación o sustitución de un artículo, póngase en contacto con su distribuidor. No se aceptarán envíos de material a nuestra fábrica sin nuestra aceptación previa por escrito.

Las piezas de desgaste no están cubiertas por la garantía.

### 6.6 Final de vida del aparato



El símbolo del contenedor tachado relativo al tratamiento y la revalorización de los residuos eléctricos y electrónicos significa que, en ningún caso, estos productos deberán ser desechados en la basura doméstica, con los residuos voluminosos ni en un vertedero.

Al final de su vida, el aparato deberá ser objeto de una recogida selectiva con vistas a su reciclaje o revalorización. En los países de la Unión Europea y en Noruega se ha implementado un circuito específico de recuperación para este tipo de productos.

Contactar con el instalador o el representante local para proceder a la recogida, el desmantelamiento y el reciclaje de este aparato.

El procesamiento de residuos del líquido refrigerante, del aceite y de otras piezas deberá ser efectuado por un profesional cualificado y calificado en conformidad con las legislaciones locales y nacionales vigentes.

Si el producto contiene pilas que portan este símbolo, esto significa que las pilas pueden contener sustancias nocivas o contaminantes. En este caso, deposite las pilas en un punto de recogida de pilas usadas.

*Página en blanco intencionalmente*



# HAYWARD®

## *FULL INVERTER*

BOMBA DE AQUECIMENTO PARA PISCINAS



HP5091DT3HA	HP5111DT3HA	HP5151DT3HA	HP5181DT3HA
-------------	-------------	-------------	-------------

Manual de instalação e de instruções

# RESUMO

---

<b>1. INSTRUÇÕES GERAIS - SEGURANÇA</b>	<b>1</b>
<hr/>	
<b>2. CARACTERÍSTICAS TÉCNICAS</b>	<b>5</b>
2.1 Dados técnicos da bomba de aquecimento	5
2.2 Período de funcionamento	6
2.3 Dimensões	7
<hr/>	
<b>3. INSTALAÇÃO E LIGAÇÃO</b>	<b>8</b>
3.1 Diagrama esquemático	8
3.2 Bomba de aquecimento	8
3.3 Ligação hidráulica	10
3.4 Ligação eléctrica	11
3.5 Primeira colocação em serviço	12
3.6 Ajuste do débito de água	14
<hr/>	
<b>4. INTERFACE DO UTILIZADOR</b>	<b>15</b>
4.1 Apresentação geral	15
4.2 Configuração de data e hora	17
4.3 Ajuste dos Temporizadores Funcionamento/Paragem	18
4.4 Ajuste do ponto de instrução	20
4.5 Bloqueio e libertação do ecrã táctil	21
4.6 Ajustamento do modo SILÊNCIO	22
<hr/>	
<b>5. MANUTENÇÃO E PREPARAÇÃO PARA O INVERNO</b>	<b>25</b>
5.1 Manutenção	25
5.2 Preparação para o Inverno	25
<hr/>	
<b>6. ANEXOS</b>	<b>26</b>
6.1 Esquemas eléctricos	26
6.2 Ligações prioridade aquecimento bomba monofásica	28
6.3 Vistas explodidas e peças sobressalentes	30
6.4 Guia de resolução de avarias	34
6.5 Garantia	37
6.6 Fim de vida do aparelho	37

Ler atentamente e conservar para consulta posterior.

Este documento deve ser entregue ao proprietário da piscina e deve ser conservado por este em local seguro.

# 1. INSTRUÇÕES GERAIS - SEGURANÇA

---

Agradecemos-lhe pela compra desta bomba de calor para piscina Hayward. A bomba de calor Hayward FULL INVERTER foi concebida segundo estritas normas de fabrico para satisfazer os mais elevados níveis de qualidade requeridos.

As bombas de calor Hayward oferecem-lhe desempenhos excecionais ao longo de toda a época de utilização da sua piscina, adaptando a potência, o consumo elétrico e o nível sonoro à sua necessidade de aquecimento, graças à lógica de controlo FULL INVERTER.



***Leia atentamente as instruções deste manual antes de utilizar o aparelho.***

O presente manual inclui todas as informações necessárias sobre a instalação, a eliminação de falhas de funcionamento e a conservação.

Leia atentamente este manual antes de abrir a unidade, ou realizar nesta operações de manutenção. O fabricante deste produto não será em caso algum responsável em caso de ferimento de um utilizador ou de deterioração da unidade consecutivos a eventuais erros aquando da instalação, da eliminação de falhas ou de uma manutenção inútil. É fundamental seguir em todas as ocasiões as instruções especificadas neste manual.

Depois de ter lido este manual, guarde-o para utilização posterior.

## **Pessoal habilitado**

- A instalação, as ligações elétricas, a manutenção e as reparações do aparelho devem ser efetuadas por um profissional autorizado conforme os textos regulamentares e as regras da arte em vigor no país onde o aparelho é instalado (cf § 3.4). Para qualquer intervenção no circuito frigorífico, o profissional deve ser titular de um atestado de capacidade para o manuseamento de fluidos refrigerantes..

Para França:

- Instalação elétrica de baixa tensão conforme a NF-C 15-100.
- Legislação sobre o manuseamento dos fluidos refrigerantes: Decreto 2007/737 e suas portarias de aplicação.

# 1. INSTRUÇÕES GERAIS - SEGURANÇA (continuação)

## Este produto contém gás refrigerante R32



*Este aparelho contém R32.*

*Jamais utilizar um refrigerante diferente do R32. A mistura de qualquer outro elemento gasoso com o R32 pode provocar pressões anormalmente elevadas, suscetíveis de provocar uma avaria ou a rutura de tubos e possíveis ferimentos de pessoas*

*Aquando de reparações ou operações de manutenção, utilizar tubos de cobre conformes à Norma NF EN 12375-1 e à Diretiva Europeia dos equipamentos sob pressão 97/23/CE.*

*A bomba de calor está sob pressão, portanto jamais perfurar os tubos nem tentar efetuar uma brasagem. Há um risco de explosão.*

*Nunca expor o aparelho a chamas, faíscas ou qualquer outra fonte de ignição. Este poderia explodir e causar ferimentos graves ou mesmo mortais.*

*Para a deteção de fugas de fluido refrigerante: não utilizar lâmpada halóide nem qualquer outro detetor que utilize uma chama aberta. Em nenhuma circunstância devem ser utilizadas fontes potenciais de inflamação.*

Este produto contém gases com efeito de estufa fluorados que estão enquadrados pelo protocolo de Quioto.

Não libertar estes gases na atmosfera.

Valor GWP(1) : 675, valor baseado no 4.º relatório do GIEC

Grupo de segurança : A2L.

A quantidade de refrigerante baseada na regulamentação F-Gás n.º 517/2014 está indicada na placa de identificação da unidade.

Toda a intervenção sobre o circuito frigorífico deve ser efetuada por um profissional autorizado como especificado anteriormente.

Podem ser requeridas inspeções periódicas em função da legislação europeia ou local. Queira contactar o seu distribuidor local para mais informações.

- Atenção, os fluidos refrigerantes podem ser inodoros.
- Não perfurar ou aquecer a tubagem, risco de explosão e de queimaduras graves.
- Não utilizar meios de aceleração do processo de degelo ou de limpeza que não sejam os recomendados pelo fabricante.
- O aparelho deve ser armazenado num local que não contenha fontes de inflamação funcionando em permanência (por exemplo: chamas abertas, aparelho de gás ou radiador elétrico em funcionamento).

(1) Potencial de aquecimento global

# 1. INSTRUÇÕES GERAIS - SEGURANÇA (continuação)

## Condições de instalação

- Esta bomba de calor é exclusivamente destinada a aquecer a água da piscina, não utilizar este material para outros fins.
- Não tente instalar si mesmo este aparelho.
- Se detetar qualquer defeito ou situação anormal, não instale a bomba de calor e contate imediatamente o seu revendedor.
- Em caso de armazenamento da bomba de calor, esta deve ser armazenada num local corretamente ventilado que tenha uma superfície no solo superior a  $A_{mín}(m^2)$ , estabelecida pela seguinte fórmula:  $A_{mín} = (M / (2,5 \times 0,22759 \times h_0))^2$   
M sendo a carga de refrigerante no aparelho em kg e  $h_0$  a altura de armazenamento. Para um armazenamento no solo  $h_0 = 0,6$  m.
- Este produto foi exclusivamente concebido para um uso doméstico e uma instalação no exterior. O ar que escapa do produto deve poder escoar-se livremente e não deve ser utilizado para outros fins como o aquecimento ou o arrefecimento de uma sala ou de um edifício.
- Verificar o cabo de alimentação. Se o cabo de alimentação estiver danificado, deve ser substituído pelo fabricante, pelo seu serviço pós-venda ou por uma pessoa qualificada e habilitada.
- A ligação do aparelho à terra e a sua continuidade são obrigatórias. O fio de terra deve ser mais longo do que os outros fios para evitar riscos de choque elétrico em caso de arrancamento do cabo. A instalação elétrica deve obrigatoriamente estar equipada com uma proteção diferencial de 30 mA (cf § 3.4).
- Verificar que o suporte previsto para a unidade foi adequadamente dimensionado para o peso do aparelho.
- **Qualquer recomendação não cumprida anula a garantia.**

## Instruções para a conservação - manutenção

As operações de manutenção devem ser realizadas 1 vez por ano a fim de garantir a longevidade e o bom funcionamento da bomba de aquecimento.

- A manutenção e as diferentes operações devem ser realizadas com a frequência e nos momentos recomendados, como especificado no presente manual.
- Utilize apenas peças sobressalentes de origem.
- Verificar o cabo de alimentação. Se o cabo de alimentação estiver danificado, deve ser substituído pelo fabricante, pelo seu serviço pós-venda ou por uma pessoa qualificada e habilitada.
- Verificar a ligação do aparelho à terra e a sua continuidade.

# 1. INSTRUÇÕES GERAIS - SEGURANÇA (continuação)

- Limpar o evaporador com a ajuda de uma escova macia ou jacto de ar ou água (**Atenção, nunca utilizar um aspersor de alta pressão**).
- Verificar o bom escoamento dos condensados.
- Verificar o aperto das ligações hidráulicas e eléctricas
- Verificar a estanqueidade hidráulica do condensador.
- **Solicitar a um profissional** com formação que verifique a impermeabilidade do circuito frigorífico através do detetor de fugas.



***Antes de qualquer operação de manutenção a bomba de aquecimento deve ser desligada de qualquer fonte de corrente eléctrica. As operações de manutenção devem ser realizadas unicamente por pessoal qualificado e habilitado para manipular fluidos de refrigeração..***

## Instruções para o Inverno

- Colocar a bomba de aquecimento em Modo “OFF”.
- Cortar a alimentação da bomba de aquecimento.
- Esvaziar o condensador com a ajuda do dreno para evitar qualquer risco de degradação. (risco importante de congelação).
- Fechar a válvula de “by-pass” e desapertar as uniões de entrada/saída.
- Expulsar ao máximo a água residual do condensador com a ajuda de uma pistola de ar.
- Obturar a entrada e a saída de água na bomba de aquecimento para evitar a entrada de corpos estranhos.
- Cobrir a bomba de aquecimento com a capa de Inverno prevista para este efeito.



***Qualquer dano ocasionado por deficiente preparação para o Inverno implica a anulação da garantia..***

## Condições de utilização

Este aparelho pode ser utilizado por crianças com pelo menos 8 anos de idade assim como por pessoas com capacidades físicas, sensoriais ou mentais reduzidas, ou sem experiência ou conhecimentos, se forem corretamente supervisionadas ou se tiverem recebido instruções relativas à utilização do aparelho com toda a segurança e os riscos incorridos tiverem sido compreendidos.

As crianças não devem brincar com o aparelho.

A limpeza e a conservação pelo utilizador não devem ser efetuadas por crianças sem vigilância.



## 2. CARACTERÍSTICAS TÉCNICAS

### 2.1 Dados técnicos da bomba de aquecimento

Modelos	FULL INVERTER	HP5091DT3HA	HP5111DT3HA	HP5151DT3HA	HP5181DT3HA
Tensão de alimentação	V	220V-240V ~/ 1fase / 50Hz			
Refrigerante	/	R32			
Carga	kg	0,430	0,450	0,60	0,670
Massa em tCO <sub>2</sub> eq	/	0,29	0,30	0,41	0,45
Frequência de controlo de fuga	/	Nenhuma exigência mas é recomendado que esta seja anual			
Capacidade de aquecimento Mín--Máx <sup>(a)</sup>	kW	2,46 -- 9,17	2,36 -- 11,45	3,31 -- 15,90	3,2 -- 18,15
Potência elétrica absorvida Mín--Máx <sup>(a)</sup>	kW	0,17 -- 1,45	0,17 -- 1,80	0,27 -- 2,84	0,22 -- 3,13
Corrente nominal de serviço Mín--Máx <sup>(a)</sup>	A	1,17 -- 6,42	1,19 -- 7,85	1,37 -- 12,35	1,45 -- 13,58
COP (coeficiente de desempenho) Máx--Mín <sup>(a)</sup>	/	14,37 -- 6,32	13,88 -- 6,35	12,26 -- 5,59	14,34 -- 5,80
Capacidade de aquecimento Mín--Máx <sup>(b)</sup>	kW	1,75 -- 7,05	1,56 -- 8,00	3,05 -- 12,40	2,86 -- 14,11
Potência elétrica absorvida Mín--Máx <sup>(b)</sup>	kW	0,27 -- 1,51	0,279 -- 1,74	0,42 -- 2,65	0,43 -- 2,99
COP (coeficiente de desempenho) Máx--Mín <sup>(b)</sup>	/	6,40 -- 4,65	5,60 -- 4,80	7,26 -- 4,68	6,63 -- 4,71
Corrente máxima de serviço (CMS)	A	8,40	9,50	14	15,9
Calibre do fusível	aM	10	12	16	20
Disjuntor curva D	D	10	12	16	20
Corrente de arranque	A	< CMS			
Ligação hidráulica	mm	50 mm			
Caudal de água nominal <sup>(a)</sup>	m <sup>3</sup> /h	4,00	5,00	6,70	7,70
Perda de carga na água máx	kPa	3,80	4,0	6,3	10
Compressor	/	DC Inverter Panasonic		DC Inverter Mitsubishi	
Tipo	/	Duplo Rotativo		Duplo Rotativo	
Quantidade	/	1			
Resistência de enrolamento a 20°C	Ohm	1,208		0,95	
Ventilador	/	Axial			
Quantidade	/	1			
Diâmetro	mm	405		510	
Número de pás	/	3			
Motor	/	DC Inverter			
Quantidade	/	1			
Velocidade de rotação	Rpm	400 -- 700	500 -- 850	300 -- 750	400 -- 750
Velocidade Modo Silêncio	Rpm	400	500	300	400
Nível de pressão acústica a 1 m	dB(A)	50,2	53,9	50,8	54,0
Nível de pressão acústica a 10 m	dB(A)	32,8	34,2	33,8	37,25
Dimensões (sem embalagem) da unidade (C-L-A)	mm	1003 / 418 / 605		1048 / 437 / 768	
Peso	kg	44	45	66	70

(a) Ar seco 27°C - Humidade relativa 78% - Temperatura de entrada da água 26°C.



(b) Ar seco 15°C - Humidade relativa 71% - Temperatura de entrada da água 26°C

## 2. CARACTERÍSTICAS TÉCNICAS (continuação)

---

### 2.2 Período de funcionamento

Utilizar a bomba de aquecimento nos seguintes intervalos de temperatura e humidade para assegurar um funcionamento seguro e eficaz.

	Modo de aquecimento 	Modo de Refrigeração 
Temperatura exterior	-7°C – +35°C	+7°C – +43°C
Temperatura da água	+12°C – +32°C	+8°C – +40°C
Humidade relativa	< 80%	< 80%
Intervalo de Ajuste do ponto de afinação	+15°C – +32°C	+8°C – +32°C



***Se a temperatura e a humidade não corresponderem a estas condições, podem disparar os dispositivos de segurança e a bomba de aquecimento pode deixar de funcionar.***



***A temperatura máxima de aquecimento é limitada à 32°C a fim de evitar a deterioração dos liners. Hayward declina qualquer responsabilidades em caso de utilização que ultrapassa os +32°C.***

## 2. CARACTERÍSTICAS TÉCNICAS (continuação)

### 2.3 Dimensões

Modelos:

HP5091DT3HA / HP5111DT3HA / HP5151DT3HA / HP5181DT3HA

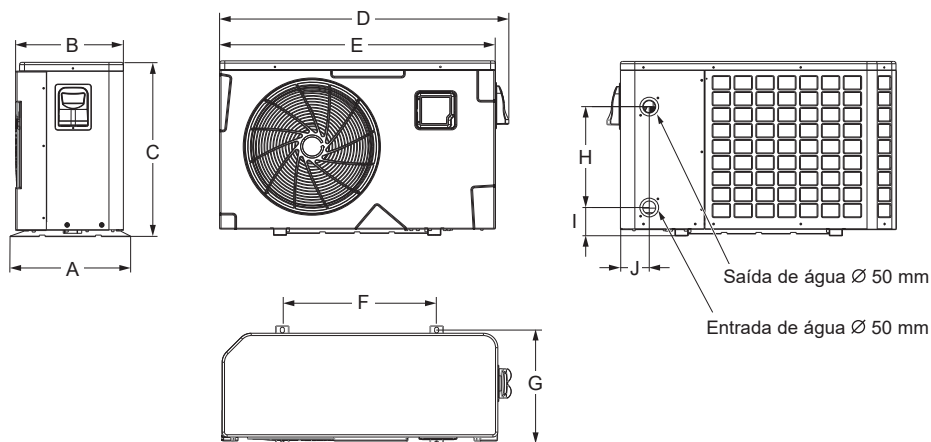

Unidade : mm

Referência \ Tipo	HP5091DT3HA / HP5111DT3HA	HP5151DT3HA	HP5181DT3HA
A	418	436,5	473
B	374	418	451,5
C	604,5	767,5	862
D	1003	1047,5	1160,5
E	956	1002	1115
F	535	615	790
G	394,5	410	447
H	350	350	466
I	97,7	101,2	97,6
J	99,2	106,5	113,5

## 3. INSTALAÇÃO E LIGAÇÃO

### 3.1 Diagrama esquemático

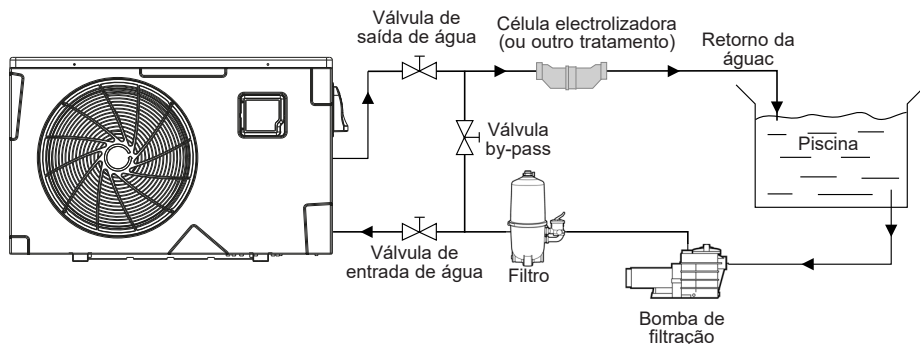

Nota: A bomba de aquecimento é fornecida sem qualquer equipamento de tratamento ou filtração. Os elementos presentes no esquema são peças a fornecer pelo instalador.

### 3.2 Bomba de aquecimento



**Colocar a bomba de aquecimento no exterior e fora de qualquer local técnico fechado.**

**Escolher uma localização de preferência ensolarada e ao abrigo de ventos dominantes.**

**O aparelho deve estar perfeitamente acessível para os trabalhos de instalação e de manutenção ulteriores.**

**Colocada sob abrigo, devem ser respeitadas as distâncias mínimas prescritas abaixo a fim de evitar qualquer risco de recirculação de ar e de degradação dos desempenhos globais da bomba de aquecimento.**

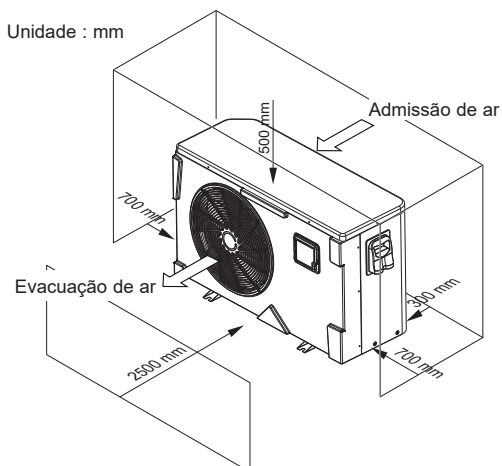

### 3. INSTALAÇÃO E LIGAÇÃO (continuação)



**Não colocar o aparelho diretamente no solo porque isto pode provocar perturbações.**

**A posição no solo sobre blocos anti-vibrações deve ser privilegiada. Um suporte de parede não deve ser utilizado em condições suscetíveis de transmitir vibrações.**

**Não instalar a bomba de calor sobre um suporte suscetível de amplificar as vibrações da unidade.**

**Não instalar a bomba de calor num lugar suscetível de amplificar o seu nível sonoro ou num lugar onde o ruído da unidade possa incomodar a vizinhança.**

**Não utilizar adesivos: estes não são considerados como meios de fixação fiáveis.**

**Instalar de preferência a bomba de calor sobre uma laje de betão plana e dessolidarizada ou uma caixa de fixação prevista para este efeito e montar a bomba de aquecimento sobre os blocos amortecedores fornecidos (parafusos e anilhas fornecidos).**

**Fixar o aparelho respeitando o aperto indicado para evitar qualquer risco de acidente ou danos para os materiais e as pessoas.**

**Outra possibilidade: instalar a bomba de calor no solo sobre suportes em borracha, utilizando um conjunto de parafusos adaptado (não fornecido).**

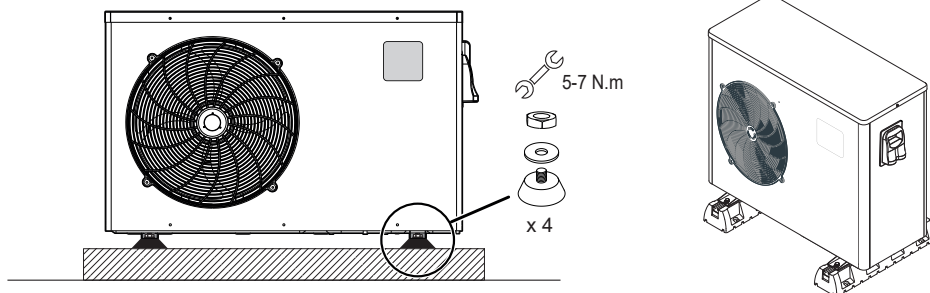

**Distância máxima de instalação entre a bomba de aquecimento e a piscina 15 metros.**

**Comprimento total ida e volta das canalizações hidráulicas 30 metros. Isolar as canalizações hidráulicas de superfície e enterradas.**

**A bomba de calor deve ser instalada a uma distância mínima da piscina de acordo com a norma NF C 15-100 (ou seja, a 3,5 m da massa de água, em França) ou com as normas de instalação em vigor noutros países.**

**Não instalar a bomba de calor junto a fontes de calor.**

**Em caso de instalação em regiões com ocorrência de neve, recomenda-se manter a máquina abrigada para evitar a acumulação de neve no evaporador.**

## 3. INSTALAÇÃO E LIGAÇÃO (continuação)

---

### 3.3 Ligação hidráulica

A bomba de aquecimento é fornecida com duas uniões de 50 mm de diâmetro. Utilizar tubo PVC para canalização hidráulica Ø 50 mm. Ligar a entrada de água da bomba de aquecimento à conduta proveniente do grupo de filtração e, em seguida, ligar a saída de água da bomba de aquecimento à conduta de água que segue para a bacia (consultar esquema abaixo).

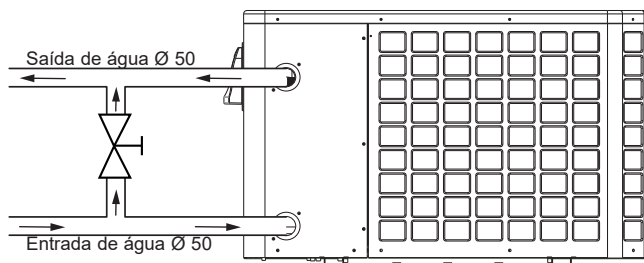

Instalar uma válvula dita de "by-pass" entre a entrada e a saída da bomba de aquecimento.



***Se for utilizado um distribuidor automático, deve obrigatoriamente ser instalado após a bomba de aquecimento a fim de proteger o condensador Titane contra uma concentração demasiado elevada de produto químico.***



***Tenha o cuidado de instalar a bomba de by-pass e as uniões fornecidas ao nível de entrada e saída de água da unidade, a fim de simplificar a purga durante o período de Inverno, facilitar o acesso ou a respectiva desmontagem para manutenção.***

### 3. INSTALAÇÃO E LIGAÇÃO (continuação)

#### 3.4 Ligação eléctrica



**A instalação eléctrica e a cablagem deste equipamento devem estar em conformidade com a regras de instalação locais em vigor.**

F	NF C15-100	GB	BS7671:1992
D	DIN VDE 0100-702	EW	EVHS-HD 384-7-702
A	ÖVE 8001-4-702	H	MSZ 2364-702/1994/MSZ 10-553 1/1990
E	UNE 20460-7-702 1993, RECBT ITC-BT-31 2002	M	MSA HD 384-7-702.S2
IRL	Regras de cablagem + IS HD 384-7-702	PL	PN-IEC 60364-7-702:1999
I	CEI 64-8/7	CZ	CSN 33 2000 7-702
LUX	384-7.702 S2	SK	STN 33 2000-7-702
NL	NEN 1010-7-702	SLO	SIST HD 384-7-702.S2
P	RSIUEE	TR	TS IEC 60364-7-702



**Verifique que a alimentação eléctrica disponível e a frequência da rede correspondem à corrente de funcionamento requerida, tendo em conta a localização específica do equipamento, e a corrente necessária para alimentar qualquer outro aparelho ligado ao mesmo circuito.**

**HP5091DT3HA / HP5111DT3HA / HP5151DT3HA / HP5181DT3HA  
230V ~ +/- 10 % 50 Hz 1 Fase**

**Observe o esquema de cablagem correspondente em anexo.  
A caixa de ligações encontra-se do lado direito da unidade. Três ligações destinam-se à alimentação eléctrica, e duas ao comando da bomba de filtração (Servocomando).**

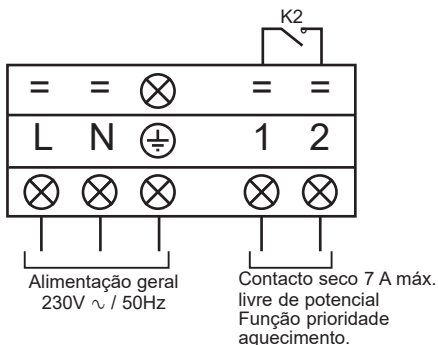

### 3. INSTALAÇÃO E LIGAÇÃO (continuação)

---



**Nunca utilizar uma tomada de corrente para a alimentação. A linha de alimentação eléctrica deve ser dotada, de maneira apropriada, de um dispositivo de proteção omnipolar do tipo disjuntor curva D, assim como de um disjuntor diferencial de proteção 30 mA (ver tabela abaixo).**

Modelos		HP5091DT3HA	HP5111DT3HA	HP5151DT3HA	HP5181DT3HA
Alimentação eléctrica	V/Ph/Hz	230V~ 50Hz	230V~ 50Hz	230V~ 50Hz	230V~ 50Hz
Disjuntor curvo D	A	8 D	10 D	16 D	20 D
Secção de cabo	mm <sup>2</sup>	3G 2,5	3G 2,5	3G 2,5	3G 4



**Utilizar o cabo de alimentação do tipo RO2V / R2V ou equivalente.**



**As secções de cabo são fornecidas para um comprimento máximo de 25 m. Devem no entanto ser verificadas e adaptadas em função das condições de instalação.**



**Tenha sempre o cuidado de interromper a alimentação principal antes de abrir a caixa de comando eléctrico.**

**Após o seccionamento da alimentação, aguardar 10 minutos antes de aceder às partes ativas internas do equipamento (energia armazenada nos condensadores).**

#### 3.5 Primeira colocação em serviço

Procedimento de arranque - uma vez a instalação terminada, seguir e respeitar as etapas seguintes:

- 1) Faça girar os ventiladores com a mão a fim de verificar que ele pode girar livremente com a mão, e que a hélice está fixada correctamente sobre o eixo do motor.
- 2) Assegure-se que a unidade está correctamente ligada à alimentação principal (ver esquema de cablagem em anexo).
- 3) Active a bomba de filtração.
- 4) Verifique que todas as válvulas de água estão abertas, e que a água flui para a unidade antes de passar ao modo de aquecimento ou refrigeração.
- 5) Verifique que o tubo de purga de condensados está correctamente fixado e não apresenta nenhuma obstrução.
- 6) Active a alimentação eléctrica destinada à unidade, depois prima a tecla Marche/Arrêt (Marcha/Paragem)  no painel de comando.



### 3. INSTALAÇÃO E LIGAÇÃO (continuação)

---

- 7) Certifique-se de que os símbolos de alarme ou de bloqueio não são visualizados. Se for o caso, consultar o guia de resolução de problemas (consulte a secção 6.4).
- 8) Fixe o débito de água com a ajuda da válvula de by-pass (ver § 3.6 e 2.1), conforme previsto respectivamente para cada modelo, de modo a obter uma diferença de temperatura Entrada/Sáida de 2°C.
- 9) Após um funcionamento de alguns minutos, verifique que o ar que sai da unidade é refrigerado (entre 5 e 10°).
- 10) Com a unidade em serviço, desactive a bomba de filtração. A unidade deve parar automaticamente e apresentar o código de erro E03.
- 11) Faça funcionar a unidade e a bomba da piscina 24 horas sobre 24, até que seja atingida a temperatura da água pretendida. Quando a temperatura de entrada de água atingir o valor de afinação, a unidade pára. Volta então a arrancar automaticamente (desde que a bomba da piscina esteja em serviço) se a temperatura da piscina for inferior em pelo menos 0,5°C à temperatura regulada.

**Controlador de débito** - A unidade é dotada de um controlador de débito que activa a bomba de calor quando a bomba de filtração da piscina está em serviço, e desactiva-a quando a bomba de filtração está fora de serviço. Por falta de água, aparece no regulador o código de alarme E03 (Ver § 6.4).

**Temporização** - a unidade integra uma temporização de 3 minutos, a fim de proteger os componentes do circuito de comando, eliminar qualquer instabilidade em termos de re-arranque e qualquer interferência ao nível do contactor. Graças a esta temporização, a unidade voltar a arrancar automaticamente cerca de 3 minutos após qualquer corte do circuito de comando. Mesmo um corte de corrente de curta duração activa a temporização de arranque.

### 3. INSTALAÇÃO E LIGAÇÃO (continuação)

---

#### 3.6 Ajuste do débito de água

Com as válvulas de entrada e saída de água abertas, ajustar a válvula de “by-pass” de modo a obter uma diferença de 2°C entre a temperatura de entrada e saída de água (ver esquema de princípio § 3.1). Pode verificar o Ajuste visualizando as temperaturas de entrada/saída directamente no painel de comando.



Nota: A abertura da válvula de “by-pass” provoca um débito menor, logo um aumento da  $\Delta T$ .  
O fecho da válvula de “by-pass” provoca um débito maior, logo uma diminuição da  $\Delta T$ .

## 4. INTERFACE DO UTILIZADOR

### 4.1 Apresentação geral

A bomba de aquecimento está equipada com um painel de comando digital com ecrã táctil, ligado electricamente e pré-regulado de fábrica em modo de aquecimento.

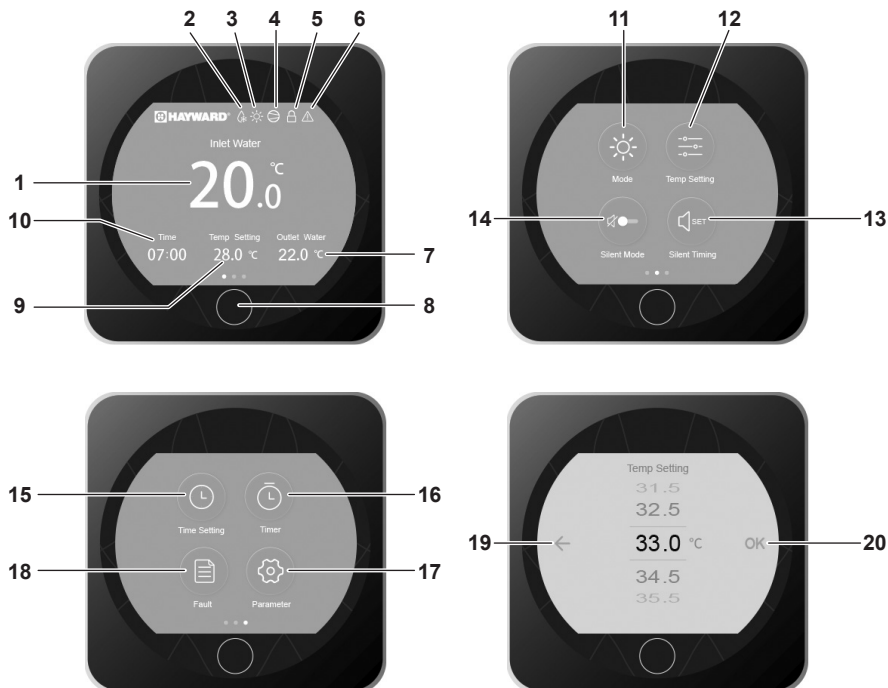

### Legenda

1	Temperatura de entrada de água
2	Descongelamento em curso
3	Modo de funcionamento
4	Indicador luminoso de funcionamento do compressor
5	Bloqueio do ecrã
6	Alarme
7	Saída de água
8	Funcionamento/Paragem/Retorno
9	Temperatura de instrução
10	Hora

11	Seleção do modo de funcionamento
12	Ajuste do ponto de instrução
13	Configurar temporizador do modo silêncio
14	Ativação do modo silêncio
15	Ajuste data e hora
16	Ajuste dos Temporizadores Funcionamento/Paragem
17	Acesso aos parâmetros avançados
18	Acesso à lista de defeitos
19	Retorno (sem validação)
20	Validação

## 4. INTERFACE DO UTILIZADOR (continuação)

### Modo OFF/PARAGEM

Quando a bomba de calor está parada (em modo de espera), a inscrição OFF aparece como indicado no ecrã.

O ecrã preto indica que a bomba de calor está parada, o ajuste dos parâmetros é possível neste modo.



### Modo ON/FUNCIÓNAMENTO

Quando a bomba de calor está em funcionamento ou em regulação (a alcançar o ponto de instrução) o ecrã torna-se azul.



Para passar do modo OFF ao modo ON e inversamente, premir o botão .

## 4. INTERFACE DO UTILIZADOR (continuação)

### 4.2 Configuração de data e hora

O ajuste da data e da hora pode ser realizado indiferentemente em modo ON ou OFF.

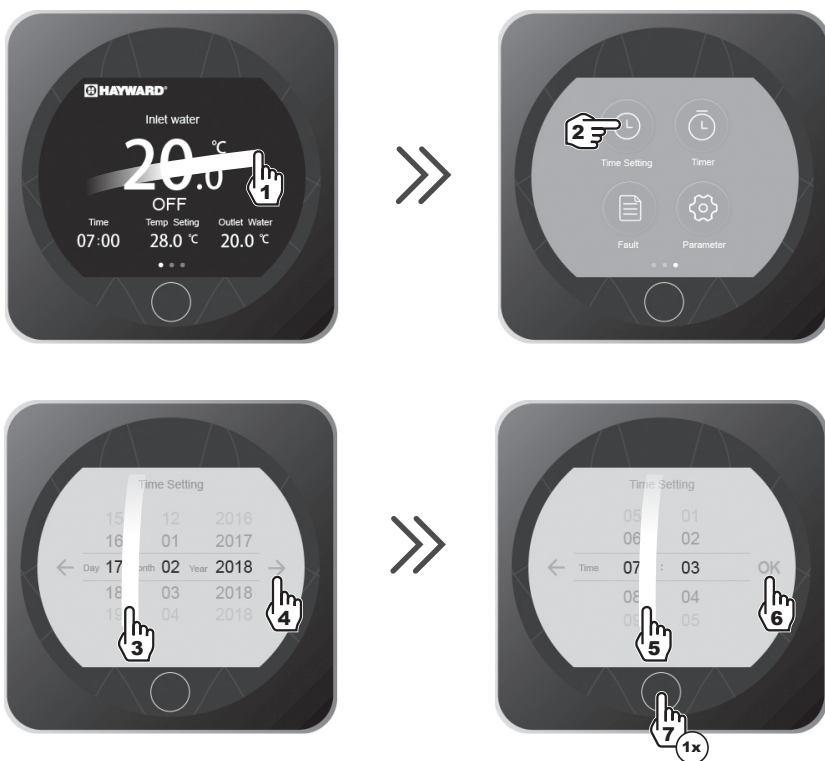

- Premir 1 vezes o botão  para voltar ao ecrã principal.

## 4. INTERFACE DO UTILIZADOR (continuação)

### 4.3 Ajuste dos Temporizadores Funcionamento/Paragem

O ajuste desta função é necessária caso pretenda fazer funcionar a bomba de aquecimento por um período mais curto que o definido pelo relógio de filtração. Pode assim programar um arranque diferido e um arranque antecipado ou simplesmente impedir um intervalo horário de funcionamento (por exemplo a noite).

É possível programar um temporizador de Arranque e um temporizador de Paragem. O ciclo de configuração é «de hora a hora».



## 4. INTERFACE DO UTILIZADOR (continuação)

---



**Azulado = Activado**  
**Acinzentado = Desactivado**

- Premir 2 vezes o botão  para voltar ao ecrã principal.

## 4. INTERFACE DO UTILIZADOR (continuação)

### 4.4 Ajuste do ponto de instrução

O ajuste do ponto de instrução realiza-se indiferentemente em modo ON ou em modo OFF com uma precisão de 0,5°C.



- Premir 1 vez o botão  para voltar ao ecrã principal.



**É recomendável nunca ultrapassar a temperatura de 30°C para evitar a alteração das juntas.**



## 4. INTERFACE DO UTILIZADOR (continuação)

### 4.5 Bloqueio e libertação do ecrã táctil

O bloqueio e o desbloqueio do ecrã pode ser efetuado indiferentemente em modo ON ou em modo OFF.



Bloqueio ativado



Bloqueio desativado

## 4. INTERFACE DO UTILIZADOR (continuação)

### 4.6 Ajustamento do modo SILÊNCIO

O modo silêncio permite utilizar a bomba de calor em modo económico e muito silencioso quando as necessidades de aquecimento são baixas (manter a temperatura da piscina ou assegurar o funcionamento ultra silencioso).

Esta função pode ser Activada/Desactivada manualmente ou usando um temporizador.

#### Ativação / Desativação



Modo silêncio desativado



Modo silêncio activado

- Premir 1 vez o botão  para voltar ao ecrã principal.

## 4. INTERFACE DO UTILIZADOR (continuação)

### Ajuste do Temporizador do modo SILÊNCIO



## 4. INTERFACE DO UTILIZADOR (continuação)



- Premir 2 vezes o botão  para voltar ao ecrã principal.



**O ciclo de configuração é «de hora a hora».**  
**Depois de o activar, o temporizador fica activo 24 horas por dia.**

## 5. MANUTENÇÃO E PREPARAÇÃO PARA O INVERNO

---

### 5.1 Manutenção

Estas operações de manutenção devem ser realizadas 1 vez por ano a fim de garantir a longevidade e o bom funcionamento da bomba de aquecimento.

- A manutenção e as reparações do aparelho devem ser efectuada por um profissional autorizado conforme os textos regulamentares e as regras da arte em vigor no país onde o aparelho é instalado (cf § 3.4). Para qualquer intervenção no circuito frigorífico, o profissional deve ser titular de um atestado de capacidade para o manuseamento de fluidos refrigerantes.
- Verificar o cabo de alimentação. Se o cabo de alimentação estiver danificado, deve ser substituído pelo fabricante, pelo seu serviço pós-venda ou por uma pessoa qualificada e habilitada.
- Verificar a ligação do aparelho à terra e a sua continuidade.
- Limpar o evaporador com a ajuda de uma escova macia ou jacto de ar ou água (**Atenção, nunca utilizar um aspersor de alta pressão**).
- Verificar o bom escoamento dos condensados.
- Verificar o aperto das ligações hidráulicas e eléctricas
- Verificar a estanqueidade hidráulica do condensador.
- **Solicitar a um profissional** com formação que verifique a impermeabilidade do circuito frigorífico através do detetor de fugas.



***Antes de qualquer operação de manutenção a bomba de aquecimento deve ser desligada de qualquer fonte de corrente eléctrica. As operações de manutenção devem ser realizadas unicamente por pessoal qualificado e habilitado para manipular fluidos de refrigeração.***

### 5.2 Preparação para o Inverno

- Colocar a bomba de aquecimento em Modo “OFF”.
- Cortar a alimentação da bomba de aquecimento.
- Esvaziar o condensador com a ajuda do dreno para evitar qualquer risco de degradação. (risco importante de congelação).
- Fechar a válvula de “by-pass” e desapertar as uniões de entrada/saída.
- Expulsar ao máximo a água residual do condensador com a ajuda de uma pistola de ar.
- Obturar a entrada e a saída de água na bomba de aquecimento para evitar a entrada de corpos estranhos.
- Cobrir a bomba de aquecimento com a capa de Inverno prevista para este efeito.



***Qualquer dano ocasionado por deficiente preparação para o Inverno implica a anulação da garantia.***



# 6. ANEXOS (continuação)

## HP5151DT3HA / HP5181DT3HA

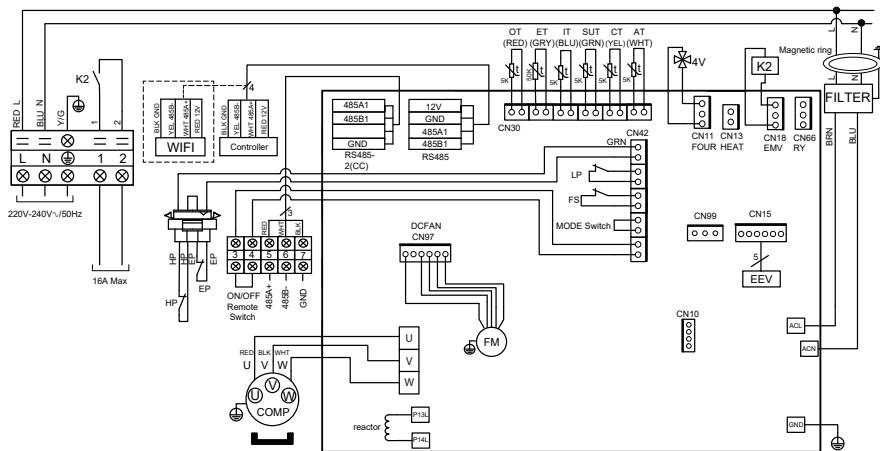

### LEGENDA

- |  |   |
|--|---|
| <b>AT</b> : SONDA DE TEMPERATURA DO AR           | <b>LP</b> : PRESSÓSTATO BAIXA PRESSÃO                 |
| <b>COMP</b> : COMPRESSOR                         | <b>OT</b> : SONDA DE TEMPERATURA SAÍDA DE ÁGUA        |
| <b>CT</b> : SONDA TEMPERATURA EVAPORADOR         | <b>SUT</b> : SONDA DE TEMPERATURA DE ASPIRAÇÃO        |
| <b>EEV</b> : REGULADOR ELECTRÓNICO               | <b>4V</b> : VÁLVULA DE 4 VIAS                         |
| <b>FM</b> : MOTOR VENTILADOR                     | <b>K2</b> : CONTACTO SECO LIVRE DE POTENCIAL 16 A MAX |
| <b>FS</b> : DETECTOR PRESENÇA DE ÁGUA            | <b>ET</b> : SONDA DE TEMPERATURA DE DESCARGA          |
| <b>HP</b> : PRESSÓSTATO ALTA PRESSÃO             | <b>---</b> : OPÇÃO                                    |
| <b>IT</b> : SONDA DE TEMPERATURA ENTRADA DE ÁGUA |   |

## 6. ANEXOS (continuação)

### 6.2 Ligações prioridade aquecimento bomba monofásica

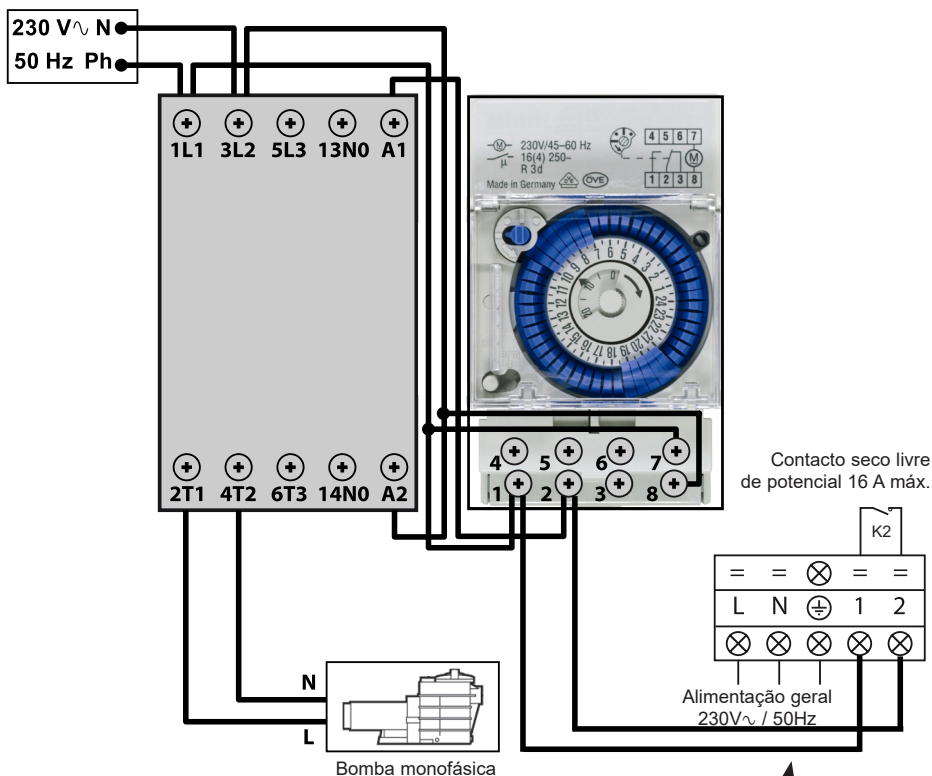

Os terminais 1 e 2 emitem um contacto seco livre de potencial, sem polaridade de 230 V ~ / 50 Hz.

Cablar os terminais 1 e 2 respeitando a cablagem indicada acima, a fim de controlar o funcionamento da bomba de filtração por ciclo de 2 minutos todas as horas se a temperatura da bacia for inferior ao ponto recomendado.

 Nunca conecte a alimentação da bomba de filtração directamente sobre os terminais 1 e 2.





---

*Página deixada em branco intencionalmente*

## 6. ANEXOS (continuação)

### 6.3 Vistas explodidas e peças sobressalentes

HP5091DT3HA / HP5111DT3HA / HP5151DT3HA / HP5181DT3HA

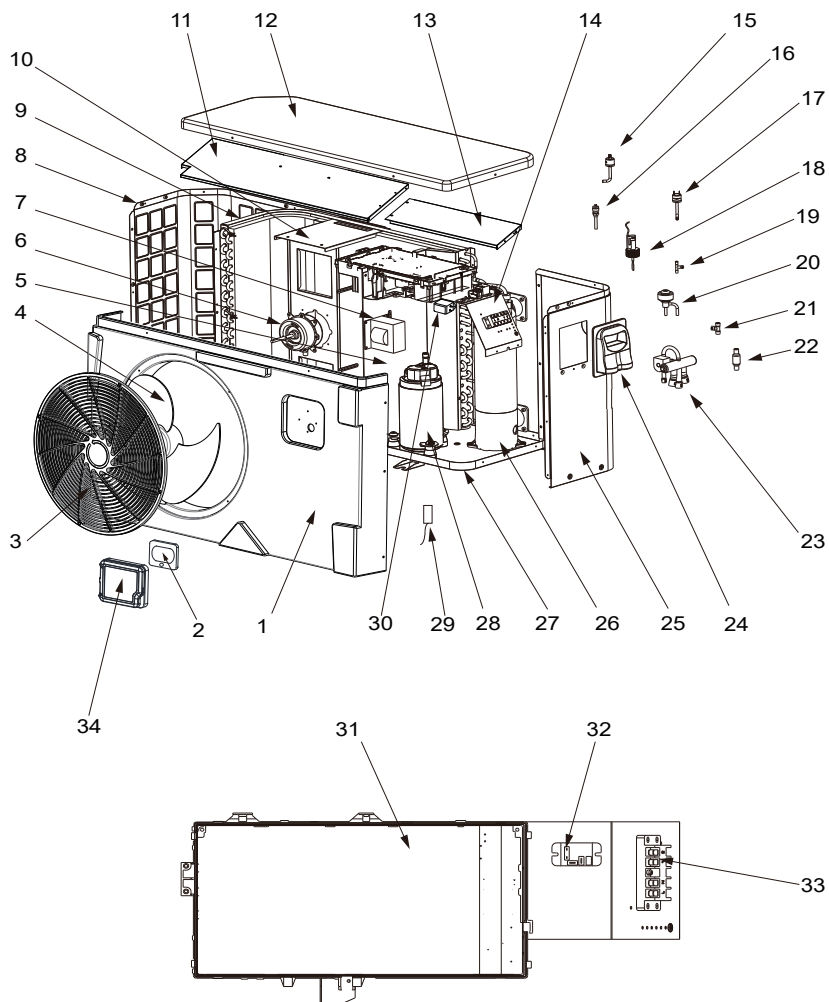

## 6. ANEXOS (continuação)

Rep	Designação	Ref.	HP5091DT3HA	HP5111DT3HA	HP5151DT3HA	HP5181DT3HA
1	Painel dianteiro	HWX80900843	✓	✓	n/a	n/a
		HWX80900844	n/a	n/a	✓	n/a
		HWX80900850	n/a	n/a	n/a	✓
2	Controlador LED	HWX72200070	✓	✓	✓	✓
3	Grelha de protecção do ventilador	HWX80900375	✓	✓	✓	n/a
		HWX20000220369	n/a	n/a	n/a	✓
4	Hélice ventilador	HWX301030000006	✓	✓	n/a	n/a
		HWX301030000001	n/a	n/a	✓	✓
5	/	/	/	/	/	/
6	Motor do ventilador DC	HWX80200018	✓	✓	n/a	n/a
		HWX20000330132	n/a	n/a	✓	✓
7	Bobina 16 A 50 Hz 5 mH	HWX82500020	✓	✓	n/a	n/a
	Bobina 20 A 50 Hz 5.2 mH	HWX82500021	n/a	n/a	✓	✓
8	Painel esquerdo	HWX80702123	✓	✓	n/a	n/a
		HWX80700244	n/a	n/a	✓	n/a
		HWX80702268	n/a	n/a	n/a	✓
9	Evaporador de alheta	HWX80600042	✓	n/a	n/a	n/a
		HWX80600043	n/a	✓	n/a	n/a
		HWX80600044	n/a	n/a	✓	n/a
		HWX80600078	n/a	n/a	n/a	✓
10	Suporte do motor	HWX80700218	✓	✓	n/a	n/a
		HWX80700248	n/a	n/a	✓	n/a
		HWX80700329	n/a	n/a	n/a	✓
11	/	/	/	/	/	/
12	Painel superior	HWX80900055	✓	✓	n/a	n/a
		HWX301090200806	n/a	n/a	✓	n/a
		HWX80900076	n/a	n/a	n/a	✓
13	/	/	/	/	/	/
14	/	/	/	/	/	/
15	Pressóstato de baixa pressão NO 0.30 MPa / 0.15 MPa	HWX20000360157	✓	✓	✓	✓
16	Tomada de pressão 40 mm-1/2"	HWX20000140150	✓	✓	✓	✓
17	Pressóstato de alta pressão NC 3.2 MPa/4.4 MPa	HWX20013605	✓	✓	✓	✓
18	Detector de débito de água	HWX83000068	✓	✓	✓	✓
19	Conector T Ø 6.5-2 x Ø 6.5(T) x 0.75	HWX20001460	✓	✓	✓	✓
20	Regulador electrónico	HWX81000011	✓	✓	n/a	n/a
		HWX81000013	n/a	n/a	✓	✓
21	Conector T Ø 9.52-2 x Ø 6.35(T) x 1.0	HWX304030000002	✓	✓	✓	✓
22	Filtro Ø 9.7-Ø 9.7 (Ø19)	HWX20000140178	✓	✓	n/a	n/a
	Filtro Ø 9.7-Ø 9.7 (Ø28)	HWX20041444	n/a	n/a	✓	✓
23	Válvula de 4 vias	HWX20041437	✓	✓	✓	✓
24	Alçapão de acesso eléctrico	HWX320922029	✓	✓	✓	✓
		HWX80700580	✓	✓	n/a	n/a
25	Painel direito	HWX80700878	n/a	n/a	✓	n/a
		HWX80700581	n/a	n/a	n/a	✓
		HWX72300013	✓	n/a	n/a	n/a
26	Condensador Titânio/PVC	HWX72300014	n/a	✓	n/a	n/a
		HWX72300010	n/a	n/a	✓	n/a
		HWX72300024	n/a	n/a	n/a	✓
27	/	/	/	/	/	/
28	Compressor	HWX80100108	✓	✓	n/a	n/a
		HWX80100046	n/a	n/a	✓	✓

## 6. ANEXOS (continuação)

HP5091DT3HA / HP5111DT3HA / HP5151DT3HA / HP5181DT3HA

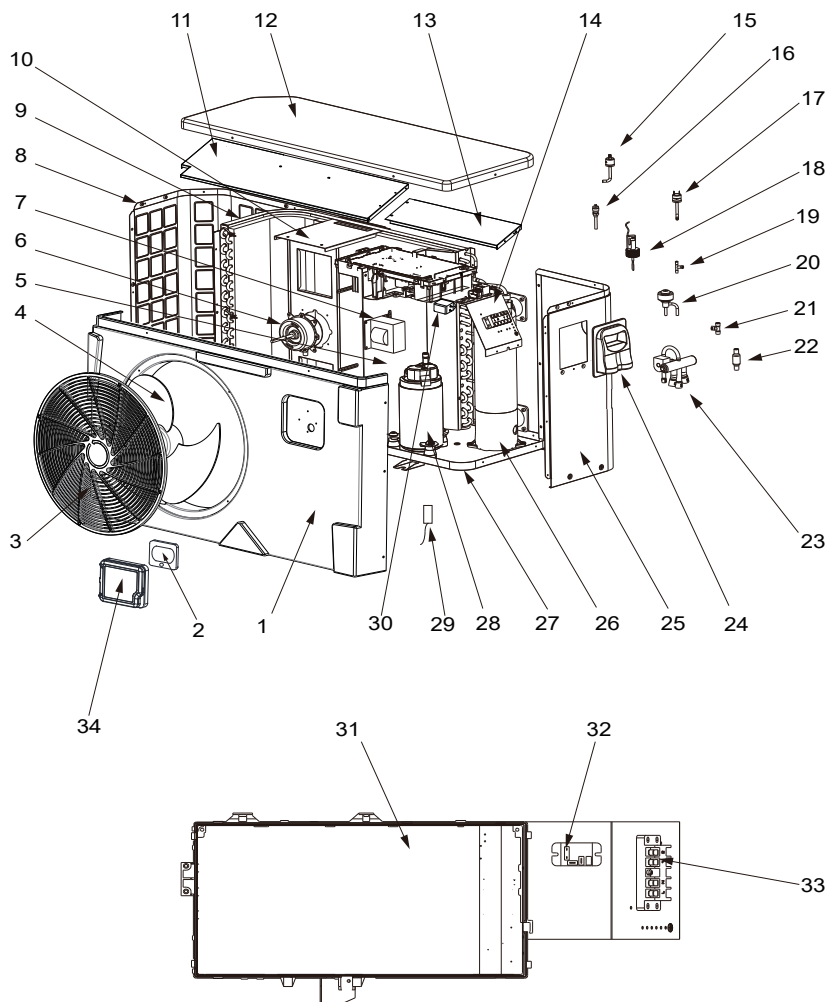

## 6. ANEXOS (continuação)

Rep	Designação	Ref.	HP5091DT3HA	HP5111DT3HA	HP5151DT3HA	HP5181DT3HA
29	Sonda de aspiração compressor 5 k - 560 mm	HWX83000044	✓	✓	n/a	n/a
	Sonda de aspiração compressor 5 k - 760 mm	HWX83000053	n/a	n/a	✓	✓
	Sonda temperatura de ar 5 k - 350 mm	HWX83000049	✓	✓	✓	✓
	Sonda de saída de água 5 k - 410 mm	HWX83000050	✓	✓	✓	✓
	Sonda de entrada de água 5 k - 850 mm	HWX83000052	✓	✓	✓	n/a
	Sonda de entrada de água 5 k - 980 mm	HWX83000055	n/a	n/a	n/a	✓
	Sonda de descarga compressor 50 k - 660 mm	HWX83000026	✓	✓	✓	✓
	Sonda descongelação 5 k - 680 mm	HWX83000051	✓	✓	n/a	n/a
Sonda descongelação 5 k - 1040 mm	HWX83000045	✓	✓	✓	✓	
30	Filtro EMC	HWX20003257	n/a	n/a	✓	✓
31	Placa eletrónica Driver	HWX72200168AP3	✓	n/a	n/a	n/a
		HWX72200168AP4	n/a	✓	n/a	n/a
		HWX72200167AP5	n/a	n/a	✓	n/a
		HWX72200167AP6	n/a	n/a	n/a	✓
32	Relés K2	HWX20000360297	✓	✓	✓	✓
33	Terminal L-N-GND -5 ligações 4 mm <sup>2</sup>	HWX40003901	✓	✓	✓	✓
34	Porta de protecção	HWX80900321	✓	✓	✓	✓

## 6. ANEXOS (continuação)

### 6.4 Guia de resolução de avarias





**Certas operações devem ser realizadas por um técnico habilitado.**

Em caso de defeito da bomba de calor, o símbolo  aparece no ângulo superior esquerdo do ecrã.

Em caso de falha, as indicações seguintes aparecem no ecrã:



**Após resolução do problema, o erro é reconhecido automaticamente, o triângulo desaparece.**

- Para apagar a lista de erros, premir .
- Premir 2 vezes o botão  para voltar ao ecrã principal.

## 6. ANEXOS (continuação)

Avaria	Códigos de erro	Descrição	Solução
Avaria sonda de entrada de água	P01	O sensor está aberto ou apresenta curto-circuito.	Verificar os conetores CN21/RES1 na placa e o conetor de extensão ou substituir o sensor
Avaria sonda de saída de água	P02		Verificar os conetores N22/RES2 na placa e o conetor de extensão ou substituir o sensor
Avaria sonda temperatura exterior	P04		Verificar os conetores CN12/PH na placa e o conetor de extensão ou substituir o sensor
Avaria sonda descongelação	P05		Verificar os conetores CN8/OPT na placa e o conetor de extensão ou substituir o sensor
Defeito sonda de aspiração compressor	P07		Verificar os conetores CN7/OAT na placa e o conetor de extensão ou substituir o sensor
Defeito sonda de descarga compressor	P081		Verificar os conetores CN9/OHT na placa e o conetor de extensão ou substituir o sensor
Protecção de alta pressão	E01	O sensor está aberto ou apresenta curto-circuito.	Verificar os conetores CN30/HP no mapa ou substituir o sensor
			Verificar o caudal de água
			Verificar o detector de caudal de água
			Verificar a abertura das válvulas
			Verificar o by-pass
			Verificar a sujidade do evaporador
			Temperatura da água muito elevada
			Problema de gás não condensável após manutenção, fechar e retirar o vácuo do circuito frigorífico
		Carga de fluido muito elevada, retirar fluido com uma garrafa	
Protecção de baixa pressão	E02	O sensor está aberto ou apresenta curto-circuito.	Verificar a ligação AI/DI03 no mapa ou substituir o sensor
			Fuga grave de fluido de refrigeração, procurar uma fuga com o detector
			Fluxo de ar muito fraco, verificar a velocidade de rotação do ventilador
			Verificar a sujidade do evaporador, limpar a superfície
Avaria detector de débito	E03	O sensor está aberto ou apresenta curto-circuito.	Verificar a ligação AI/DI02 no mapa ou substituir o sensor
			Falta de água, verificar o funcionamento da bomba de filtração
			Verificar a abertura das válvulas de paragem
			Verificar a configuração do by-pass

## 6. ANEXOS (continuação)

Avaria	Códigos de erro	Descrição	Solução
Diferença de temperatura entrada/saída > 13 °C	E06	Aplicável apenas no modo Frio	Falta de água, verificar o funcionamento da bomba de filtração
			Verificar a abertura das válvulas de paragem
			Verificar a configuração do by-pass
Protecção Antigelo	E07	Temperatura de saída da água < 4 °C	Parar a bomba de calor, esvaziar o condensador, risco de congelamento
Problema de comunicação	E08	Não há nenhuma comunicação entre a placa eletrónica e a interface do utilizador	Verificar as ligações e os conetores - ver esquema elétrico
Protecção antigelo de nível 1	E19	2 °C < Temperatura da água < 4 °C e Temperatura do ar < 0 °C	Interromper o funcionamento da bomba de calor, esvaziar o condensador para evitar o congelamento. Por defeito, a bomba de calor inicia a bomba de filtração e a bomba de calor para evitar a entrada de gelo.
Protecção antigelo de nível 2	E29	Temperatura da água < 2 °C e Temperatura do ar < 0 °C	Interromper o funcionamento da bomba de calor, esvaziar o condensador para evitar o congelamento. Por defeito, a bomba de calor inicia a bomba de filtração e a bomba de calor para evitar a entrada de gelo.
Defeito do motor ventilador	F031	Motor bloqueado ou defeito de ligação	Verificar a sua livre rotação; verificar os conetores CN97/DCFan; substituir o motor
Defeito do motor ventilador	F051	Defeito de ligação	Verificar os conetores DCFAN/CN97; substituir o motor
Temperatura exterior demasiado baixa	TP	Limite de funcionamento atingido	Parar a bomba de calor



## 6. ANEXOS (continuação)

---

### 6.5 Garantia

#### CONDIÇÕES DE GARANTIA

Todos os produtos HAYWARD são garantidos contra todos os defeitos de fabrico ou de matéria-prima durante um período de dois anos a contar da data de aquisição. Qualquer reclamação de garantia deverá ser acompanhada de uma prova de compra contendo a data. Recomendamos, assim, que conserve a sua factura.

A garantia HAYWARD é limitada à reparação ou substituição, por opção da HAYWARD, dos produtos defeituosos desde que tenham sido submetidos a uma utilização normal, em conformidade com as prescrições mencionadas no respectivo manual de utilização, que o produto não tenha sido modificado de nenhuma forma e tenha sido utilizado unicamente com componentes e peças da HAYWARD. Os danos devidos ao gelo e aos ataques de agentes químicos não são garantidos. Todas as outras despesas (transporte, mão-de-obra...) estão excluídas da garantia.

A HAYWARD não poderá ser considerada responsável por qualquer dano directo ou indirecto proveniente da instalação, da ligação ou do funcionamento incorrecto do produto.

Para fazer aplicar uma garantia ou solicitar a reparação ou substituição de um artigo, dirija-se ao seu revendedor. Não será aceite qualquer devolução de material à nossa fábrica sem o nosso acordo prévio por escrito. As peças de desgaste não se encontram cobertas pela garantia.

### 6.6 Fim de vida do aparelho



O símbolo da lixeira barrada relativo ao tratamento e à revalorização dos detritos elétricos e eletrónicos significa que em caso algum os produtos devem ser descartados com o lixo doméstico, com os itens volumosos ou num aterro.

Em fim de vida, o aparelho deve ser objeto de uma recolha seletiva com vista à sua reciclagem ou revalorização. Um circuito específico de recuperação para este tipo de produtos foi implementado nos países da União Europeia e na Noruega. Contactar o instalador ou o representante local para proceder à recolha, ao desmantelamento e à reciclagem deste aparelho.

O retratamento do líquido refrigerante, do óleo e das outras peças deve ser realizado por um profissional qualificado autorizado conforme as legislações locais e nacionais em vigor.

Se o produto contiver pilhas marcadas com este símbolo, isto significa que as pilhas podem conter substâncias nocivas ou poluentes. Neste caso, entregue as pilhas num ponto de recolha de pilhas usadas.

*Página deixada em branco intencionalmente*



# **HAYWARD<sup>®</sup>**

## ***FULL INVERTER***

**HEIZPUMPENANLAGE FÜR EIN SCHWIMMBECKEN**



HP5091DT3HA	HP5111DT3HA	HP5151DT3HA	HP5181DT3HA
-------------	-------------	-------------	-------------

**Einbau- & Anleitungshandbuch**

# INHALTSVERZEICHNIS

<b>1. ALLGEMEINE ANWEISUNGEN - SICHERHEIT</b>	<b>1</b>
<b>2. TECHNISCHE EIGENSCHAFTEN</b>	<b>5</b>
2.1 Technische Daten der Wärmepumpe	5
2.2 Betriebsbereich	6
2.3 Maße	7
<b>3. INSTALLATION UND ANSCHLUSS</b>	<b>8</b>
3.1 Schematische Darstellung	8
3.2 Heizpumpenanlage	8
3.3 Hydraulischer Anschluss	10
3.4 Elektrischer Anschluss	11
3.5 Erste Inbetriebnahme	12
3.6 Einstellung des Wasserdurchsatzes	14
<b>4. BENUTZEROBERFLÄCHE</b>	<b>15</b>
4.1 Allgemeine Darstellung	15
4.2 Einstellung Datum und Uhrzeit	17
4.3 Einstellung der Schaltuhren AN/AUS	18
4.4 Sollwerteneinstellung	20
4.5 Sperren und Entsperrern des Touchscreen	21
4.6 Aktivieren und Einstellen des SILENCE-Modus	22
<b>5. WARTUNG UND WINTERZEIT</b>	<b>25</b>
5.1 Wartung	25
5.2 Winterzeit	25
<b>6. ANHANG</b>	<b>26</b>
6.1 Stromtafel	26
6.2 Vorrangige Heizanschlüsse einphasige Pumpe	28
6.3 Explosionszeichnungen und Einzelteile	30
6.4 Anleitung zur Fehlerbehebung	34
6.5 Garantie	37
6.6 Entsorgung des ausgedienten Geräts	37

Aufmerksam lesen und für einen späteren Gebrauch aufzubewahren.

Dieses Dokument ist dem Eigentümer des Schwimmbeckens zu übergeben und muss von diesem an einem sicheren Ort aufbewahrt werden.

# 1. ALLGEMEINE ANWEISUNGEN - SICHERHEIT

---

Für den Erwerb dieser Hayward Schwimmbadwärmepumpe danken wir Ihnen. Die Hayward Wärmepumpe FULL INVERTER wurde gemäß strengen Fertigungsnormen konzipiert, um den geforderten Höchstqualitätsniveaus zu genügen.

Durch die Steuerlogik FULL INVERTER erreichte Anpassung von Leistung, Stromverbrauch und Geräuschpegel an den Heizbedarf Ihres Schwimmbades werden Ihnen die Hayward Wärmepumpen außergewöhnliche Leistungen während Ihrer gesamten Badesaison bieten.



***Vor Benutzung des Geräts lesen Sie dieses Handbuch aufmerksam durch.***

Dieses Handbuch enthält alle benötigten Informationen hinsichtlich Installation, Behebung von Funktionsstörungen und Wartung.

Lesen Sie dieses Handbuch aufmerksam durch, bevor Sie das Gerät öffnen oder Wartungsarbeiten am Gerät durchführen. Der Produkthersteller haftet in keinem Fall für die Verletzung eines Benutzers oder die Beschädigung des Geräts, die aus Fehlern bei der Installation, der Pannenbehebung bzw. aus einer nicht erforderlichen Wartung ergeben. Die in diesem Handbuch enthaltenen Anweisungen müssen jederzeit unbedingt beachtet werden.

Nachdem Sie dieses Handbuch gelesen haben, halten Sie es stets zum Nachschlagen bereit.

## **Zugelassenes Personal**

- Installation, Elektroanschlüsse, Wartung und Reparaturen des Geräts müssen von einer technischen Fachkraft durchgeführt werden, die nach den im Land, in dem das Gerät installiert ist, geltenden Bestimmungen zugelassen ist (s. § 3.4). Fachkräfte, die irgendwelche Arbeiten am Kältekreislauf durchführen, müssen ihre Befähigung zum Umgang mit Kältemitteln nachweisen können.  
Für Frankreich:
  - Elektrische Niederspannungsanlagen gemäß der Norm NF-C 15-100.
  - Gesetzgebung für den Umgang mit Kältemitteln: Dekret 2007/737 und Verfügungen zu dessen Anwendung.

# 1. ALLGEMEINE ANWEISUNGEN (Fortsetzung)

## Dieses Gerät enthält das Kältegas R32



*Dieses Gerät enthält R32.*

*Verwenden Sie niemals ein anderes Kältemittel als R32. Jeder andere gasförmiger Körper, der mit dem R32 gemischt wird, kann unnormale hohe Druckwerte verursachen, die eine Panne oder einen Rohrbruch und Personenverletzungen verursachen können.*

*Bei Reparaturen oder Wartungsmaßnahmen müssen Kupferrohre verwendet werden, die der Norm NF EN 12375-1 und der europäischen Druckgeräterichtlinie 97/23/EG entsprechen.*

*Da die Wärmepumpe unter Druck steht, bohren Sie niemals die Rohrleitungen und versuchen Sie auch nicht diese zu löten. Es besteht Explosionsgefahr.*

*Setzen Sie niemals das Gerät Flammen, Funken oder anderen Entzündungsquellen aus. Das Gerät könnte explodieren und schwere oder sogar tödliche Verletzungen verursachen.*

*Verwenden Sie zur Kältemittel-Lecksuche keine Halogenlampe oder andere, eine nackte Flamme verwendende Vorrichtungen. Auf keinen Fall dürfen Vorrichtungen, die potentielle Zündquellen enthalten, verwendet werden.*

Dieses Produkt enthält gemäß dem Kyoto-Protokoll Gase mit Treibhauseffekt. Setzen Sie diese Gase nicht in die Atmosphäre frei.

Höhe des Valeur GWP<sup>(1)</sup> : 675 Wert basierend auf 4. GIEC-Bericht.

Sicherheitsgruppe: A2L.

Die auf Grundlage der Vorschrift F Gas 517/2014 bestimmte Kältemittelmenge ist auf dem Typenschild des Geräts angegeben.

Jegliche Arbeiten am Kältekreislauf müssen, wie bereits oben gesagt, von einer zugelassenen Fachkraft ausgeführt werden.

Regelmäßige Inspektionen des Austritts von Kühlmittel können gemäß der europäischen Gesetzgebung oder der des jeweiligen Landes verlangt werden.

Für weitere Informationen kontaktieren Sie bitte Ihren Händler vor Ort.

- Achtung, Kältemittel können geruchlos sein.
- Die Rohrleitung nicht durchbohren oder erhitzen. Dies kann zu Explosionen oder schweren Verbrennungen führen.
- Verwenden Sie zur Beschleunigung des Abtauens oder zur Reinigung ausschließlich die vom Hersteller empfohlenen Mittel.
- Ein Raum, in dem das Gerät aufbewahrt wird, darf keine permanent vorhandenen Zündquellen enthalten (zum Beispiel nackte Flammen, betriebene Gasgeräte oder Elektroheizungen).

(1) Globaler Erwärmungsfaktor

# 1. ALLGEMEINE ANWEISUNGEN (Fortsetzung)

## Bedingungen für die Installation

- Diese Heizpumpe ist ausschließlich zum Heizen des Wassers eines Schwimmbeckens bestimmt und darf nicht zu anderen Zwecken verwendet werden.
- Versuchen Sie nicht, dieses Gerät selbst zu installieren.
- Falls Sie irgendwelchen Fehler bzw. unnormale Situation entdecken, installieren Sie nicht die Wärmepumpe und setzen Sie sich sofort mit Ihrem Händler in Verbindung.
- Zur Lagerung muss die Wärmepumpe in einem gut belüfteten Raum mit einer größeren Bodenfläche als durch folgender Formel errechnete  $A_{min}(m^2)$  gelagert werden:  $A_{min} = (M / (2.5 \times 0.22759 \times h_0))^2$   
M ist die Kältemittelfüllung im Gerät in und  $h_0$  ist die Lagerungshöhe. Bei Lagerung auf dem Boden  $h_0 = 0,6$  m.
- Dieses Gerät ist ausschließlich für den Hausgebrauch und eine Installation im Freien bestimmt. Aus dem Gerät entweichende Luft muss ungehindert ausströmen können und darf nicht zu irgendwelchen Zwecken, wie zum Heizen oder Kühlen eines Raums oder eines Gebäudes verwendet werden.
- Das Netzkabel prüfen. Ist das Netzkabel beschädigt, so muss es vom Hersteller, dessen Kundendienst oder einer hierzu befähigten und zugelassenen Person ersetzt werden.
- Das Gerät muss unbedingt durchgängig geerdet werden. Zur Vermeidung der Gefahr eines Stromschlags beim Abreißen des Kabels muss der Erdungsleiter länger sein als die anderen Leiter. Die Elektroinstallation muss unbedingt mit einem 30 mA-Fehlerstrom-Schutzschalter versehen sein (s. § 3.4).
- Prüfen Sie, dass der für das Gerät vorgesehene Träger für das Gerätgewicht korrekt dimensioniert ist.
- **Im Falle einer Nichtbeachtung dieser Anweisungen erlischt der Garantieanspruch.**

## Anweisungen für Instandhaltung und Wartung

Maßregeln zur Wartung müssen ein Mal pro Jahr durchgeführt werden, um die Langlebigkeit und gute Funktionsweise der Heizpumpenanlage zu garantieren.

- Die Wartung und die verschiedenen Betriebsabläufe müssen gemäß den in diesem Handbuch beschriebenen Zeiträumen und Häufigkeiten durchgeführt werden.
- Benutzen Sie ausschließlich Originalersatzteile.
- Das Netzkabel prüfen. Ist das Netzkabel beschädigt, so muss es vom Hersteller, dessen Kundendienst oder einer hierzu befähigten und zugelassenen Person ersetzt werden.
- Den Erdungsanschluss des Geräts und die Durchgängigkeit des Erdungsleiters prüfen.

# 1. ALLGEMEINE ANWEISUNGEN (Fortsetzung)

- Reinigen Sie den Evaporator mit Hilfe einer flexiblen Bürste, einem Luft- oder einem Wasserstrahl. **Achtung: Verwenden Sie niemals einen Hochdruckreiniger.**
- Kontrollieren Sie den korrekten Abfluss des Kondensats.
- Kontrollieren Sie die hydraulischen und elektrischen Anschlüsse.
- Kontrollieren Sie die hydraulische Dichtigkeit des Kondensator.
- Die Dichtheit des Kältekreislaufs mithilfe eines Leckdetektors **durch eine autorisierte Fachkraft** prüfen lassen.



***Vor allen Wartungsmaßnahmen muss die Heizpumpenanlage von jeglicher Stromversorgung getrennt werden. Die Wartungsmaßnahmen müssen von einem qualifizierten Fachmann durchgeführt werden, dem der Umgang mit Kälteflüssigkeiten vertraut ist.***

## Anleitung zum Überwintern

- Stellen Sie die Heizpumpenanlage auf den Modus "OFF".
- Trennen Sie die Heizpumpenanlage von der Stromversorgung.
- Leeren Sie den Kondensator mit Hilfe des Wasserablassers, um jegliche Schadensgefahr zu vermeiden. (großes Frostrisiko).
- Schließen Sie den By-pass-Schieber und lösen Sie die Eingangs- und Ausgangsverbindungsstücke.
- Entfernen Sie so gut es geht das Altwasser im Kondensator mit Hilfe einer Druckluftpistole.
- Verschließen Sie den Wasserein- und -ausgang an der Heizpumpenanlage, um das Eindringen von Fremdkörpern zu verhindern.
- Decken Sie die Heizpumpenanlage mit der für diesen Zweck vorgesehenen Winterschutzhülle ab.



***Jeglicher Schaden, der durch eine schlechte Winterlagerung entsteht, hebt alle Garantieansprüche auf.***

## Benutzungsbedingungen

Mindestens 8 Jahre alte Kindern, Personen mit eingeschränkten körperlichen, sensorischen oder geistigen Fähigkeiten oder Personen mit mangelnder Erfahrung und mangelnden Kenntnissen können dieses Gerät verwenden, soweit sie hierbei hinreichend überwacht werden, oder Anweisungen zur sicheren Verwendung des Geräts erhalten haben und damit verbundene Risiken berücksichtigt wurden. Kinder dürfen nicht mit dem Gerät spielen. Vom Benutzer durchführbare Reinigungs- und Wartungsmaßnahmen dürfen nicht ohne Überwachung von Kindern vorgenommen werden.



## 2. TECHNISCHE EIGENSCHAFTEN

### 2.1 Technische Daten der Wärmepumpe

Modelle	FULL INVERTER	HP5091DT3HA	HP5111DT3HA	HP5151DT3HA	HP5181DT3HA
Versorgungsspannung	V	220V-240V ~ / 1ph / 50Hz			
Kältemittel	/	R32			
Ladung	kg	0.430	0.450	0.60	0.670
Gewicht in t CO <sub>2</sub> -Äquivalent	/	0.29	0.30	0.41	0.45
Lecktest-Häufigkeit	/	Nicht vorgeschrieben aber jährlich empfohlen			
Wärmeleistung Min--Max <sup>(a)</sup>	kW	2.46 -- 9.17	2.36 -- 11.45	3.31 -- 15.90	3.2 -- 18.15
Elektrische Leistungsaufnahme Min--Max <sup>(a)</sup>	kW	0.17 -- 1.45	0.17 -- 1.80	0.27 -- 2.84	0.22 -- 3.13
Nennstrom im Betrieb Min--Max <sup>(a)</sup>	A	1.17 -- 6.42	1.19 -- 7.85	1.37 -- 12.35	1.45 -- 13.58
COP Max--Min <sup>(a)</sup>	/	14.37 -- 6.32	13.88 -- 6.35	12.26 -- 5.59	14.34 -- 5.80
Wärmeleistung Min--Max <sup>(b)</sup>	kW	1.75 -- 7.05	1.56 -- 8.00	3.05 -- 12.40	2.86 -- 14.11
Elektrische Leistungsaufnahme Min--Max <sup>(b)</sup>	kW	0.27 -- 1.51	0.279 -- 1.74	0.42 -- 2.65	0.43 -- 2.99
COP Max--Min <sup>(b)</sup>	/	6.40 -- 4.65	5.60 -- 4.80	7.26 -- 4.68	6.63 -- 4.71
Maximaler Betriebsstrom (MBS)	A	8.40	9.50	14	15.9
Sicherungswert	aM	10	12	16	20
Schutzschalter Typ D	D	10	12	16	20
Anlaufstrom	A	< MBS			
Hydraulikanschluss	mm	50 mm			
Nenn-Wasserdurchsatz <sup>(a)</sup>	m <sup>3</sup> /h	4.00	5.00	6.70	7.70
Max. wasserseitiger Druckverlust	kPa	3.80	4.0	6.3	10
Kompressor	/	DC Inverter Panasonic		DC Inverter Mitsubishi	
Typ	/	Zweistufiger Schraubenkompressor		Zweistufiger Schraubenkompressor	
Anzahl	/	1			
Wicklungswiderstand bei 20°C	Ohm	1.208		0.95	
Gebläse	/	Axial			
Anzahl	/	1			
Durchmesser	mm	405		510	
Schaufelanzahl	/	3			
Motor	/	DC Inverter			
Anzahl	/	1			
Drehzahl	U/Min.	400 --700	500 -- 850	300 --750	400 --750
Drehzahl im Ruhemodus	U/Min.	400	500	300	400
Schalldruckpegel in 1 m Abstand	dB(A)	50.2	53.9	50.8	54.0
Schalldruckpegel in 10 m Abstand	dB(A)	32.8	34.2	33.8	37.25
Nettoabmessungen des Geräts (L-B-H)	mm	1003 / 418 / 605		1048 / 437 / 768	1161 / 473 / 862
Gewicht	kg	44	45	66	70



(a) Trockene Luft 27°C - Relative Feuchte 78% - Wassereinlasstemperatur 26°C.  
 (b) Trockene Luft 15°C - Relative Feuchte 71% - Wassereinlasstemperatur 26°C

## 2. TECHNISCHE EIGENSCHAFTEN (Fortsetzung)

---

### 2.2 Betriebsbereich

Benutzen Sie die Heizpumpenanlage innerhalb der folgenden Temperatur- und Luftfeuchtigkeitsbereichen, um ein sicheres und effizientes Funktionieren zu garantieren.

	Modus Erwärmen 	Modus Abkühlen 
Außentemperatur	-7°C – +35°C	+7°C – +43°C
Wassertemperatur	+12°C – +32°C	+8°C – +40°C
relative Luftfeuchtigkeit	< 80%	< 80%
Einstellbereich des Sollwerts	+15°C – +32°C	+8°C – +32°C



***Wenn Temperatur oder Luftfeuchtigkeit nicht diesen Bedingungen entsprechen, können Sicherheitsmaßnahmen ausgelöst werden. Dann arbeitet die Heizpumpenanlage nicht mehr.***



***Die Höchsttemperatur für die Beheizung beträgt 32 °C, um eine Beschädigung der Verkleidung zu vermeiden. Hayward übernimmt keinerlei Verantwortung bei einer Verwendung über +32 °C.***

## 2. TECHNISCHE EIGENSCHAFTEN (Fortsetzung)

### 2.3 Maße

Modelle:

HP5091DT3HA / HP5111DT3HA / HP5151DT3HA / HP5181DT3HA

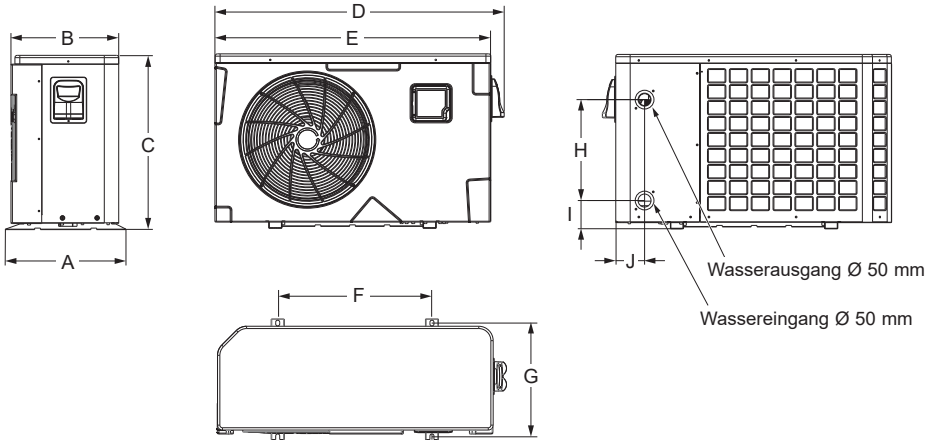

Einheit : mm

Markierung \ Modell	HP5091DT3HA / HP5111DT3HA	HP5151DT3HA	HP5181DT3HA
<b>A</b>	418	436,5	473
<b>B</b>	374	418	451,5
<b>C</b>	604,5	767,5	862
<b>D</b>	1003	1047,5	1160,5
<b>E</b>	956	1002	1115
<b>F</b>	535	615	790
<b>G</b>	394,5	410	447
<b>H</b>	350	350	466
<b>I</b>	97,7	101,2	97,6
<b>J</b>	99,2	106,5	113,5

# 3. INSTALLATION UND ANSCHLUSS

## 3.1 Schematische Darstellung

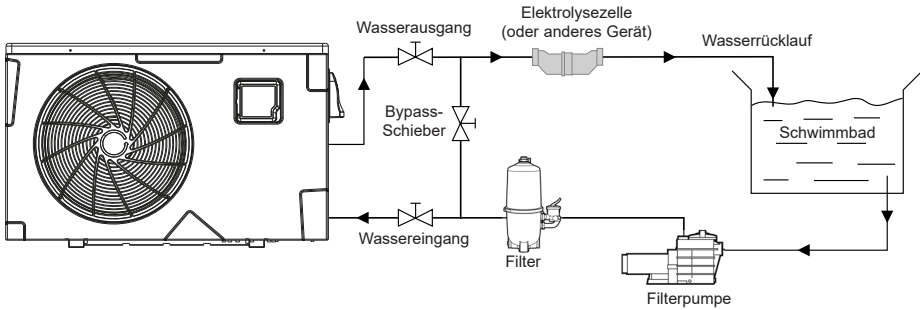

Anmerkung: Die Heizpumpenanlage verfügt über keinerlei Ausstattungs- oder Filtergerät. Die auf der Darstellung gezeigten Elemente werden vom Installateur bereitgestellt.

## 3.2 Heizpumpenanlage



**Stellen Sie die Heizpumpenanlage im Außenraum und außerhalb vollständig geschlossener technischer Orte auf.**  
**Platzieren Sie das Gerät möglichst an einer sonnenbeschienenen und gegen vorherrschende Winde geschützten Stelle.**  
**Das Gerät muss für spätere Installations- und Wartungsarbeiten vollständig zugänglich bleiben.**  
**Geschützt aufgestellt muss der vorgeschriebene Mindestabstand wie unten genannt eingehalten werden, um die Gefahr einer Luftrückführung oder einer Minderung der effektiven Betriebsleistung der Heizpumpenanlage zu vermeiden.**

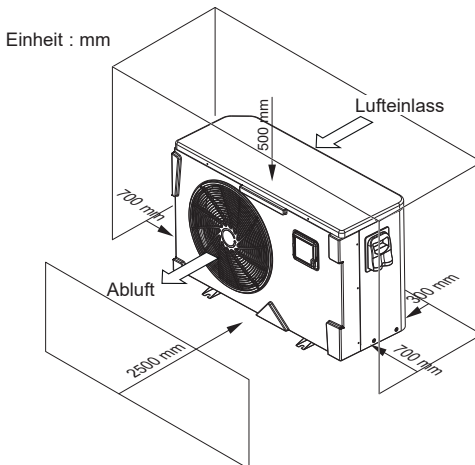

### 3. INSTALLATION UND ANSCHLÜSSE (Fortsetzung)



**Stellen Sie das Gerät nicht direkt auf dem Boden ab, da dies zu Störungen führen kann.**

**Montieren Sie das Gerät zur Aufstellung auf dem Boden möglichst auf Vibrationsdämpfern.**

**Unter Bedingungen, bei denen Vibrationen übertragen werden können, darf das Gerät nicht an einer Wandbefestigung montiert werden.**

**Installieren Sie die Heizpumpe nicht auf einem Träger, der die Vibrationen des Geräts verstärken könnte.**

**Installieren Sie die Heizpumpe nicht an einem Ort, an dem ihr Schallpegel verstärkt oder die Nachbarschaft durch ihre Geräusche gestört werden könnte.**

**Verwenden Sie keine Klebstoffe. Solche gewährleisten keine zuverlässige Befestigung.**

**Installieren Sie das Wärmepumpensystem vorzugsweise auf einer ebenen, separaten Betonbodenplatte.**

**Stellen Sie das Wärmepumpensystem auf die mitgelieferten Silentblöcke (Schrauben und Unterlegscheiben werden mitgeliefert).**

**Befestigen Sie das Gerät mit den vorgeschriebenen Anziehdrehmomenten, um jegliche Gefahr von Unfällen mit Sach- und Personenschäden zu vermeiden.**

**Die Heizpumpe kann auch mit geeigneten Schraubelementen (nicht geliefert) auf Gummiuntersätzen am Boden befestigt werden.**

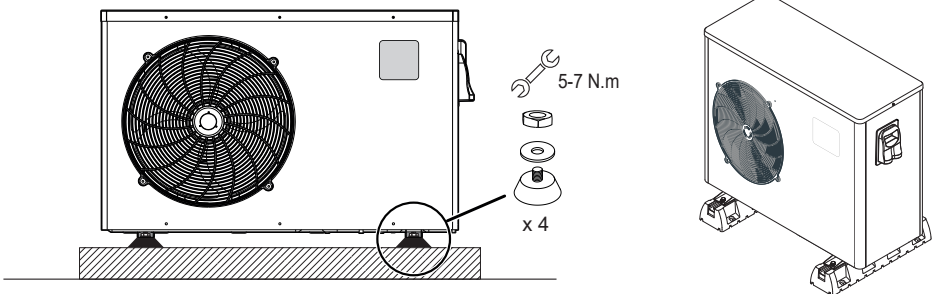

**Maximale Entfernung zwischen Heizpumpenanlage und Schwimmbecken 15 Meter.**

**Gesamtlänge (hin und zurück) der hydraulischen Leitungen 30 Meter. Isolieren Sie sowohl die sichtbaren als auch die verdeckten hydraulischen Leitungen.**

**Die Wärmepumpe ist mit einem Mindestabstand vom Becken gemäß NF C 15-100 (d. h. für Frankreich 3,5 m entfernt von der Wasseroberfläche) oder gemäß den in den jeweiligen Ländern geltenden Installationsstandards zu installieren.**

**Die Wärmepumpe nicht in der Nähe einer Wärmequelle installieren.**

**Bei einer Installation in schneereichen Gebieten wird eine Abdeckung der Maschine empfohlen, um eine Schneeanhäufung auf dem Verdampfer zu verhindern.**

## 3. INSTALLATION UND ANSCHLUSS (Fortsetzung)

---

### 3.3 Hydraulischer Anschluss

Die Heizpumpenanlage wird mit zwei Verbindungsstücken mit einem Durchmesser von 50 mm geliefert. Verwenden Sie PVC-Rohre mit 50 mm Durchmesser für das hydraulische Leitungsnetz. Schließen sie die den Wassereinlass der Heizpumpenanlage an die Leitung der Filtergruppe an. Schließen Sie dann den Wasserausgang der Heizpumpenanlage an die Wasserleitung des Beckens an (s. Darstellung weiter unten).

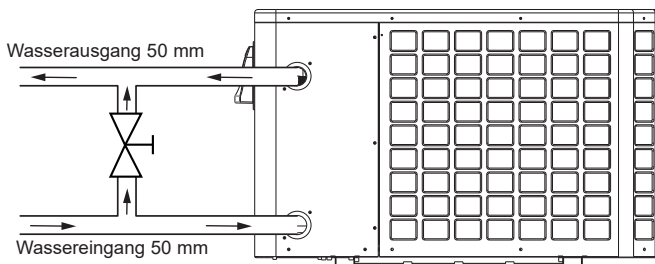

Installieren Sie einen Schieber, den so genannten "By-pass", zwischen den Eingang und den Ausgang der Heizpumpenanlage.



***Wird ein automatischer Verteiler oder ein Elektrolyseur verwendet, muss dieser unbedingt nach der Heizpumpenanlage eingebaut werden, um so den Titan-Kondensator gegen eine zu hohe Konzentration chemischer Produkte zu schützen.***



***Achten Sie darauf, den By-pass-Schieber und die Verbindungsstücke am Ein- und Auslass der Anlage einzubauen, um den problemlosen Ablass der Anlage während der Wintermonate und einen einfacheren Zugang oder einen Abbau bei Wartungsarbeiten zu erleichtern.***

# 3. INSTALLATION UND ANSCHLÜSSE (Fortsetzung)

## 3.4 Elektrischer Anschluss



**Die Elektroinstallation und die Verkabelung dieses Gerätes müssen den geltenden Installationsvorschriften vor Ort entsprechen.**

F	NF C15-100	GB	BS7671:1992
D	DIN VDE 0100-702	EW	EVHS-HD 384-7-702
A	ÖVE 8001-4-702	H	MSZ 2364-702/1994/MSZ 10-553 1/1990
E	UNE 20460-7-702 1993, RECBT ITC-BT-31 2002	M	MSA HD 384-7-702.S2
IRL	Wiring Rules (Richtlinien elektrischer Leitungen, Anm. d. Übers.) + IS HD 384-7-702	PL	PN-IEC 60364-7-702:1999
I	CEI 64-8/7	CZ	CSN 33 2000 7-702
LUX	384-7.702 S2	SK	STN 33 2000-7-702
NL	NEN 1010-7-702	SLO	SIST HD 384-7-702.S2
P	RSIUEE	TR	TS IEC 60364-7-702



**Prüfen Sie, ob die verfügbare Stromversorgung und die Netzfrequenz den den erforderlichen Betriebsstrom entsprechen. Dabei müssen der jeweilige Standort des Gerätes und der erforderliche Strombedarf aller anderen, am gleichen Schaltkreis angeschlossener Geräte berücksichtigt werden.**

**HP5091DT3HA / HP5111DT3HA / HP5151DT3HA / HP5181DT3HA  
230V ~ +/- 10 % 50 Hz 1 Phase**

**Beachten Sie die schematische Darstellung der Verkabelung im Anhang. Die Anschlussbox befindet sich auf der rechten Seite der Anlage. Es gibt drei Anschlüsse für die Stromversorgung und zwei für die Steuerung der Filterpumpe (Nachlaufsteuerung).**

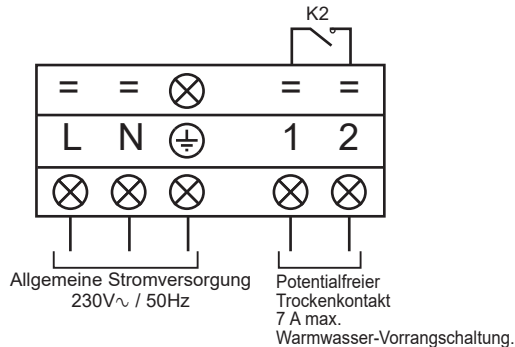

### 3. INSTALLATION UND ANSCHLUSS (Fortsetzung)



**Schließen Sie das Gerät auf keinen Fall an einer Netzsteckdose an. Die Stromversorgungsleitung muss mit einem allpoligen Schutzgerät vom Typ D-Kurven-Schutzschalter sowie einem 30-mA-Differentialschutz-Schutzschalter ausgestattet sein (siehe nachfolgende Tafel).**

Modelle		HP5091DT3HA	HP5111DT3HA	HP5151DT3HA	HP5181DT3HA
Stromversorgung	V/Ph/Hz	230V~ 50Hz	230V~ 50Hz	230V~ 50Hz	230V~ 50Hz
Leistungsschalter Kurve D	A	8 D	10 D	16 D	20 D
Leitungsquerschnitt	mm <sup>2</sup>	3G 2,5	3G 2,5	3G 2,5	3G 4



**Ein Netzkabel vom Typ RO2V / R2V oder vergleichbar.**



**Die Leitungsquerschnitte werden für maximal 25 m Länge angegeben. Sie müssen gleichwohl überprüft und auf die Installationsbedingungen angepasst werden.**



**Achten Sie stets darauf, dass die Hauptstromversorgung abgeschaltet ist, bevor Sie den elektrischen Steuerkasten öffnen. Nach Trennen des Geräts von der Stromversorgung ist vor dem Zugang zu aktiven Teilen in seinem Innern 10 Minuten zu warten (es kann in Kondensatoren gespeicherte Energie enthalten).**

#### 3.5 Erste Inbetriebnahme

Verfahren zur Inbetriebnahme - Nachdem Sie die Installation beendet haben, gehen Sie wie folgt vor:

- 1) Drehen Sie die Ventilatoren von Hand, um zu überprüfen, dass sie sich frei von Hand bewegen lassen und dass der Propeller korrekt auf der Antriebswelle befestigt ist.
- 2) Vergewissern Sie sich, dass die Einheit korrekt an die Hauptstromversorgung angeschlossen ist (siehe Schaltplan im Anhang).
- 3) Starten Sie die Filterpumpe.
- 4) Vergewissern Sie sich, dass alle Wasserein- und auslässe offen sind und dass das Wasser in die Anlage, bevor es erwärmt oder abgekühlt wird.
- 5) Vergewissern Sie sich, dass das Ablassrohr für das Kondensat ordnungsgemäß befestigt und frei von Blockaden ist.
- 6) Aktivieren Sie die Stromversorgung für die Anlage und drücken Sie dann den Start/Stop-Knopf  auf der Bedientafel.



### **3. INSTALLATION UND ANSCHLUSS (Fortsetzung)**

---

- 7) Prüfen Sie, dass die Alarm- bzw. Sperrsymbole nicht aufleuchten. Siehe gegebenenfalls die Anleitung zur Pannenbehebung (siehe § 6.4).
- 8) Arretieren Sie den Wasserdurchsatz mit dem By-pass-Schieber (s. § 3.6 und 2.1), wie für das jeweilige Modell vorgeschrieben, so dass eine Temperaturdifferenz zwischen Wasserein- und -ausgang von 2°C beibehalten wird.
- 9) Nachdem die Anlage einige Minuten in Betrieb ist, vergewissern Sie sich, dass die Luft, die aus der Anlage ausströmt, sich abgekühlt hat (um 5 bis 10°).
- 10) Ist die Anlage in Betrieb, schalten Sie die Filterpumpe ab. Die Anlage sollte sich automatisch abschalten und den Fehlercode E03 anzeigen.
- 11) Lassen sie die Anlage und die Schwimmbadpumpe 24 Stunden am Tag laufen, bis die gewünschte Wassertemperatur im Pool erreicht ist. Sobald das Eingangswasser die gewünschte Temperatur erreicht hat, schaltet sich die Anlage ab. Sie wird sich dann wieder automatisch einschalten (sofern die Schwimmbadpumpe in Betrieb ist), wenn die Temperatur des Schwimmbadwassers um mehr als 0,5°C von der eingestellten Temperatur abweicht.

**Wasserdurchsatzregler** - Die Anlage ist mit einem Regler für den Wasserdurchsatz ausgestattet, der diese einschaltet, wenn die Pumpe des Schwimmbadfilters in Betrieb ist und der diese ausschaltet, wenn die Filterpumpe außer Betrieb ist. Fehlt Wasser, so erscheint der Alarm-Code E03 auf dem Regler (siehe § 6.4).

**Zeitliche Verzögerung** - Die Anlage enthält eine zeitliche Verzögerung von 3 Minuten, welche die Komponenten des Steuerschaltkreises schützt und jegliche Instabilität bezüglich eines Neustarts sowie jegliche Störung im Bereich des Kontaktgebers verhindert. Aufgrund dieser zeitlichen Verzögerung startet die Anlage ca. 3 Minuten nach jeder Unterbrechung des Steuerschaltkreises automatisch neu. Selbst eine kurze Stromunterbrechung aktiviert diese zeitliche Verzögerung.

## 3. INSTALLATION UND ANSCHLUSS (Fortsetzung)

---

### 3.6 Einstellung des Wasserdurchsatzes

Stellen Sie den so genannten By-pass-Schieber bei geöffneten Wassereinlass- und -auslassschiebern so ein, dass ein Unterschied von 2°C zwischen der Wassereingangstemp. und der Wasserausgangstemp. erreicht wird (siehe Schematische Darstellung § 3.1). Sie können die Einstellung der Eingangs- und Ausgangstemperaturen direkt auf der Bedientafel kontrollieren.



Temperatur des Wassereinlasses

Temperatur des Wasserauslasses

Anmerkung: Das Öffnen des By-pass-Schiebers führt zu einem geringeren Durchsatz oder zu einer Zunahme des  $\Delta T$ .  
Das Schließen des By-pass-Schiebers führt zu einem höheren Durchsatz oder zu einer Verringerung des  $\Delta T$ .

# 4. BENUTZEROBERFLÄCHE

## 4.1 Allgemeine Darstellung

Die Heizpumpenanlage ist mit einem digitalen Touchscreen-Bedienfeld ausgestattet, elektronisch angeschlossen und werksseitig auf Heizmodus voreingestellt.

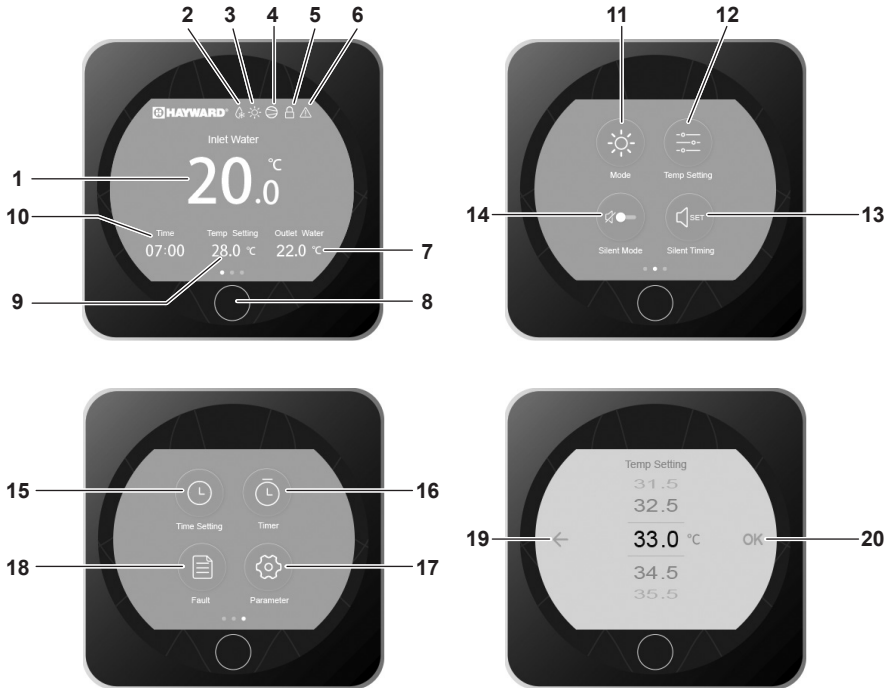

### Zeichenerklärung

1	Temperatur Wassereingang
2	Abtauenmodus
3	Betriebsmodus
4	Betriebsanzeige des Kompressors
5	Bildschirm Sperre
6	Alarm
7	Wasserauslass
8	An/Aus/Zurück
9	Solltemperatur
10	Uhrzeit

11	Auswahl der Betriebsart
12	Sollwerteeinstellung
13	Einstellung Timer Ruhemodus
14	Aktivierung des Ruhemodus
15	Datum- und Uhrzeiteinstellung
16	Einstellung der An/Aus Schaltuhren
17	Zugriff erweiterte Parameter
18	Zugriff Fehlerliste
19	Zurück (ohne Bestätigung)
20	Bestätigung

## 4. BENUTZEROBERFLÄCHE (Fortsetzung)

---

### Modus OFF/AUS

Wenn die Wärmepumpe still steht (Ruhemodus), wird OFF auf dem Bildschirm angezeigt. Ein schwarzer Bildschirm bedeutet, dass die Wärmepumpe still steht, in diesem Modus können die Parameter eingestellt werden.



### Modus ON/AN

Wenn die Wärmepumpe läuft oder sich im Regelmodus befindet (Erreichen des Sollwerts), färbt sich der Bildschirm blau.





Um vom Modus OFF auf Modus ON und umgekehrt umzuschalten, drücken Sie auf den Knopf .

## 4. BENUTZEROBERFLÄCHE (Fortsetzung)

### 4.2 Einstellung Datum und Uhrzeit

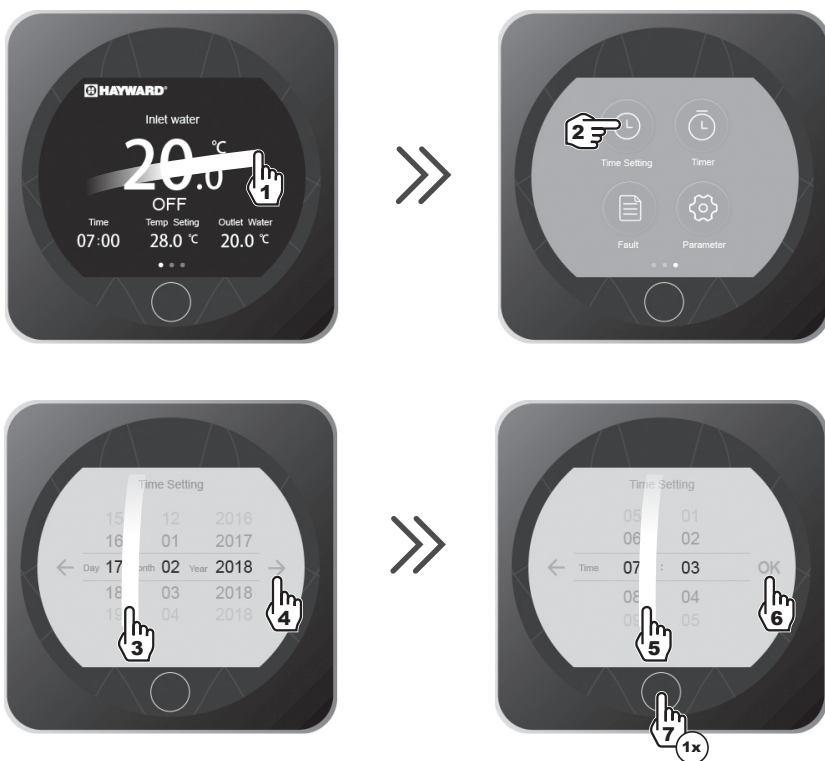
Die Datum- und Uhrzeiteinstellung kann beliebig im ON oder OFF Modus vorgenommen werden.



- Um zum Hauptbildschirm zurück zu kehren, drücken Sie 1 mal auf .

## 4. BENUTZEROBERFLÄCHE (Fortsetzung)

### 4.3 Einstellung der Schaltuhren AN/AUS

Die Einstellung dieser Funktion ist notwendig, wenn Sie die Heizpumpenanlage über einen kürzeren als den von der Filteruhr vorgegebenen Zeitraum betreiben möchten. Damit können Sie einen zeitlich versetzten Beginn oder ein vorzeitiges Ende programmieren bzw. einen Teilbereich des Betriebszeitplans unterbinden (zum Beispiel nachts).

Sie können Ein Start-Schaltuhren und Ein Stopp-Schaltuhren programmieren. Die Einstellung erfolgt in Schritten von jeweils einer Stunde.



## 4. BENUTZEROBERFLÄCHE (Fortsetzung)

---



**Blaue Hinterlegung = Aktiviert**  
**Graue Hinterlegung = Deaktiviert**

- Um zum Hauptbildschirm zurück zu kehren, drücken Sie 2 mal auf .

## 4. BENUTZEROBERFLÄCHE (Fortsetzung)

### 4.4 SollwertEinstellung

Die Einstellung des Sollwerts kann mit einer Genauigkeit von 0,5°C beliebig im Modus ON oder im Modus OFF vorgenommen werden.



- Um zum Hauptbildschirm zurück zu kehren, drücken Sie 1 mal auf .



**Es wird empfohlen, niemals eine Temperatur von 30°C zu überschreiten, um Veränderungen der Auskleidungen zu vermeiden.**



## 4. BENUTZEROBERFLÄCHE (Fortsetzung)

### 4.5 Sperren und Entsperren des Touchscreen

Die Sperre und Freigabe des Bildschirms kann beliebig im Modus ON oder im Modus OFF vorgenommen werden.



Sperre aktiviert



Sperre deaktiviert

## 4. BENUTZEROBERFLÄCHE (Fortsetzung)

### 4.6 Aktivieren und Einstellen des SILENCE-Modus

Der Ruhemodus ermöglicht eine äußerst leise Nutzung der Wärmepumpe Energiesparmodus, da der Heizbedarf gering ist (Aufrechterhaltung der Beckentemperatur oder falls extrem leiser Betrieb erforderlich).

Diese Funktion kann entweder manuell oder über eine Zeitschaltung Aktiviert/ Deaktiviert werden.

#### Aktivierung/Deaktivierung

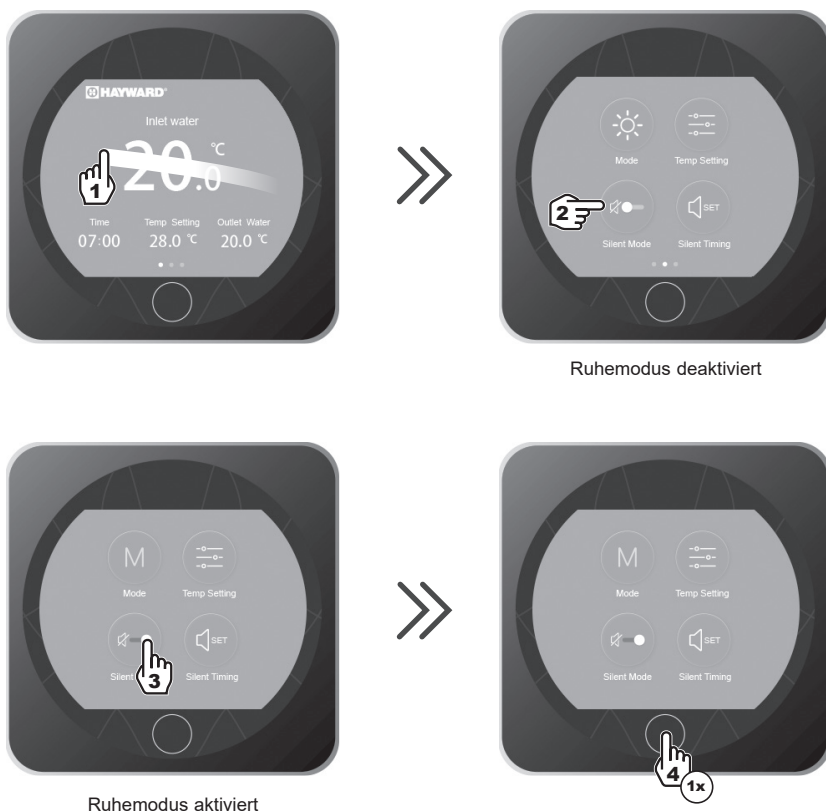

- Um zum Hauptbildschirm zurück zu kehren, drücken Sie 1 mal auf .

## 4. BENUTZEROBERFLÄCHE (Fortsetzung)

### Einstellung der Schaltuhr der RUHE-Modus



## 4. BENUTZEROBERFLÄCHE (Fortsetzung)

---



- Um zum Hauptbildschirm zurück zu kehren, drücken Sie 2 mal auf .



**Die Einstellung erfolgt in Schritten von jeweils einer Stunde. Sobald der Timer aktiviert ist, ist er 7 Tage in der Woche aktiv.**

## 5. WARTUNG UND WINTERZEIT

---

### 5.1 Wartung

Diese Maßregeln zur Wartung müssen ein Mal pro Jahr durchgeführt werden, um die Langlebigkeit und gute Funktionsweise der Heizpumpenanlage zu garantieren.

- Wartung und Reparaturen des Geräts müssen von einer technischen Fachkraft durchgeführt werden, die nach den im Land, in dem das Gerät installiert ist, geltenden Bestimmungen zugelassen ist (s. § 3.4). Fachkräfte, die irgendwelche Arbeiten am Kältekreislauf durchführen, müssen ihre Befähigung zum Umgang mit Kältemitteln nachweisen können.
- Das Netzkabel prüfen. Ist das Netzkabel beschädigt, so muss es vom Hersteller, dessen Kundendienst oder einer hierzu befähigten und zugelassenen Person ersetzt werden.
- Den Erdungsanschluss des Geräts und die Durchgängigkeit des Erdungsleiters prüfen.
- Reinigen Sie den Evaporator mit Hilfe einer flexiblen Bürste, einem Luft- oder einem Wasserstrahl (**Achtung: Verwenden Sie niemals einen Hochdruckreiniger**).
- Kontrollieren Sie den korrekten Abfluss des Kondensats.
- Kontrollieren Sie die hydraulischen und elektrischen Anschlüsse.
- Kontrollieren Sie die hydraulische Dichtigkeit des Kondensator.
- Die Dichtheit des Kältekreislaufs mithilfe eines Leckdetektors **durch eine autorisierte Fachkraft** prüfen lassen.



***Vor allen Wartungsmaßnahmen muss die Heizpumpenanlage von jeglicher Stromversorgung getrennt werden. Die Wartungsmaßnahmen müssen von einem qualifizierten Fachmann durchgeführt werden, dem der Umgang mit Kälteflüssigkeiten vertraut ist.***

### 5.2 Winterzeit

- Stellen Sie die Heizpumpenanlage auf den Modus "OFF".
- Trennen Sie die Heizpumpenanlage von der Stromversorgung.
- Leeren Sie den Kondensator mit Hilfe des Wasserablassers, um jegliche Schadensgefahr zu vermeiden. (großes Frostrisiko).
- Schließen Sie den By-pass-Schieber und lösen Sie die Eingangs- und Ausgangsverbindungsstücke.
- Entfernen Sie so gut es geht das Altwasser im Kondensator mit Hilfe einer Druckluftpistole.
- Verschließen Sie den Wasserein- und -ausgang an der Heizpumpenanlage, um das Eindringen von Fremdkörpern zu verhindern.
- Decken Sie die Heizpumpenanlage mit der für diesen Zweck vorgesehenen Winterschutzhülle ab.



***Jeglicher Schaden, der durch eine schlechte Winterlagerung entsteht, hebt alle Garantieansprüche auf.***

# 6. ANHANG

## 6.1 Stromtafel

### HP5091DT3HA / HP5111DT3HA

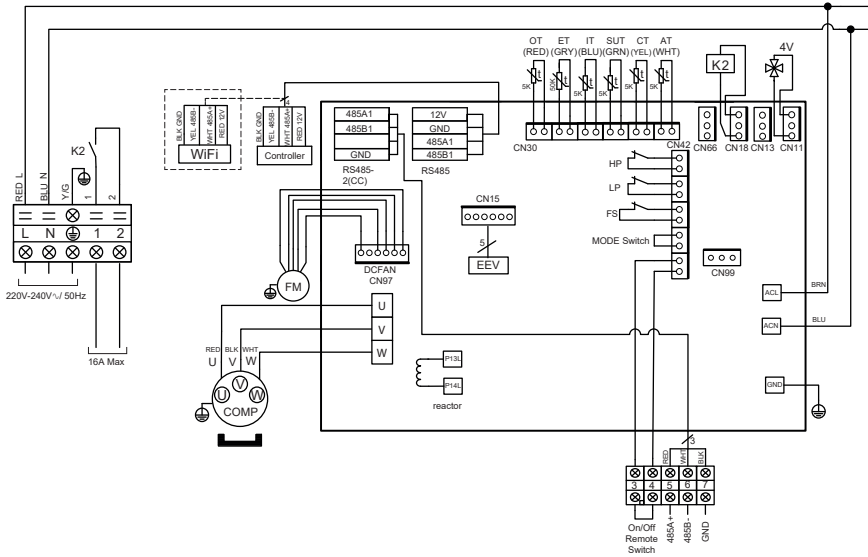

#### LEGENDE

**AT** : AUSSENTEMPERSORSOR

**COMP** : KOMPRESSOR

**CT** : TEMPERATURSENSOR DES EVAPORATORS

**EEV** : ELEKTRONISCHER SENSOR

**FM** : GEBLÄSEMOTOR

**FS** : SENSOR DES WASSERSTANDES

**HP** : HOCHDRUCKREGLER

**IT** : SENSOR DER TEMPERATUR DES WASSEREINLASSES

**LP** : NIEDRIGDRUCKREGLER

**OT** : SENSOR DER TEMPERATUR DES WASSERAUSLASSES

**SUT** : SENSOR DER SAUGTEMPERATUR

**4V** : 4-WEGE-VENTIL

**K2** : POTENTIALFREIER TROCKENKONTAKT MAX. 16 A

**ET** : DRUCKTEMPERATURSONDE

--- : OPTION

# 6. ANHANG (Fortsetzung)

## HP5151DT3HA / HP5181DT3HA

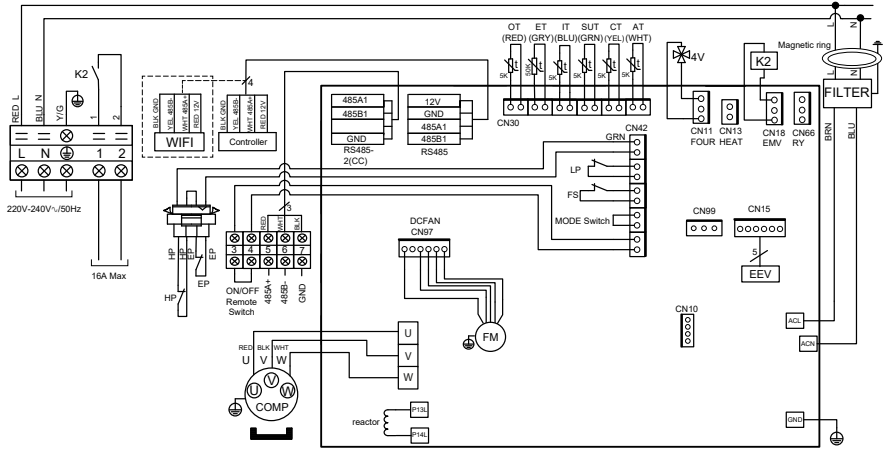

### LEGENDE

- |   |   |
|---|---|
| <b>AT</b> : AUSSENTEMPATURSENSOR                      | <b>LP</b> : NIEDRIGDRUCKREGLER                        |
| <b>COMP</b> : KOMPRESSOR                              | <b>OT</b> : SENSOR DER TEMPERATUR DES WASSERAUSLASSES |
| <b>CT</b> : TEMPERATURSENSOR DES EVAPORATORS          | <b>SUT</b> : SENSOR DER SAUGTEMPERATUR                |
| <b>EEV</b> : ELEKTRONISCHER SENSOR                    | <b>4V</b> : 4-WEGE-VENTIL                             |
| <b>FM</b> : GEBLÄSEMOTOR                              | <b>K2</b> : POTENTIALFREIER TROCKENKONTAKT MAX. 16 A  |
| <b>FS</b> : SENSOR DES WASSERSTANDES                  | <b>ET</b> : DRUCKTEMPERATURSONDE                      |
| <b>HP</b> : HOCHDRUCKREGLER                           | <b>OPTION</b> : OPTION                                |
| <b>IT</b> : SENSOR DER TEMPERATUR DES WASSEREINLASSES |   |

## 6. ANHANG (Fortsetzung)

### 6.2 Vorrangige Heizanschlüsse einphasige Pumpe

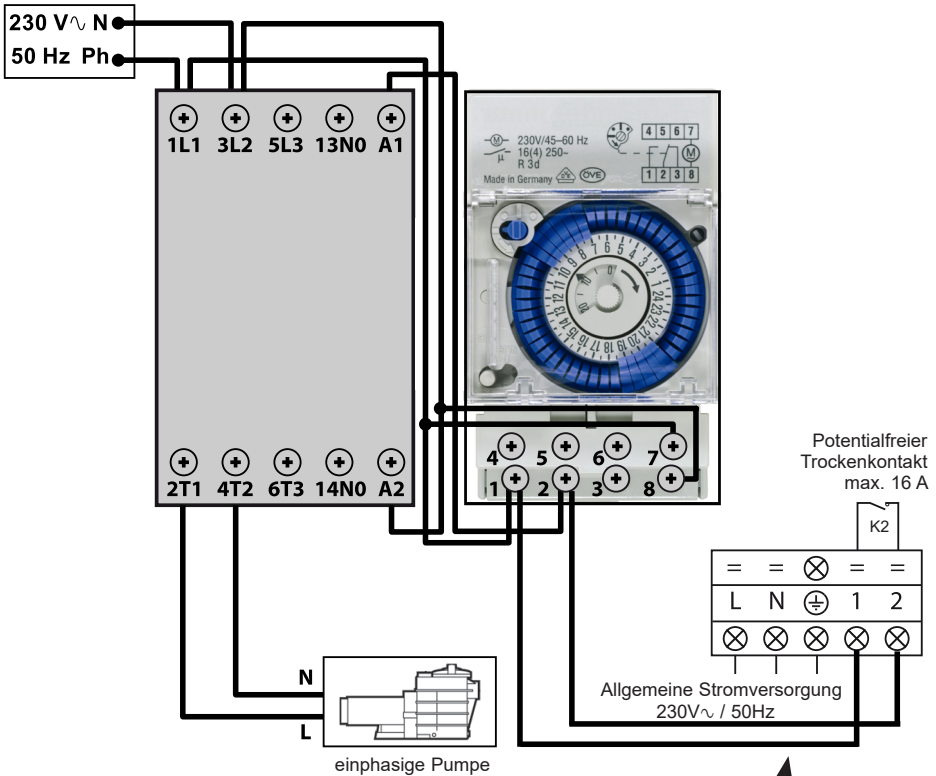

Die Anschlüsse 1 und 2 liefern einen potenzialfreien Trockenkontakt ohne Polarität 230 V $\sim$  / 50 Hz. Verkabeln Sie die Anschlüsse 1 und 2 unter Berücksichtigung des folgenden Kabelschemas, um die Filtrationspumpe jede Stunde in einem 2-Minuten-Zyklus zu aktivieren, wenn die Temperatur des Beckens unter den Sollwert fällt.

**!** Die Stromversorgung der Filtrationspumpe niemals direkt an die Anschlüsse 1 und 2 anschließen.





---

*Seite bewusst leer gelassen*



## 6. ANHANG (Fortsetzung)

Nr	Beschreibung	Ref.	HP5091DT3HA	HP5111DT3HA	HP5151DT3HA	HP5181DT3HA
1	Rückplatte	HWX80900843	✓	✓	n/a	n/a
		HWX80900844	n/a	n/a	✓	n/a
		HWX80900850	n/a	n/a	n/a	✓
2	LED Regler	HWX72200070	✓	✓	✓	✓
3	Schutzgitter des Gebläses	HWX80900375	✓	✓	✓	n/a
		HWX20000220369	n/a	n/a	n/a	✓
4	Gebläsepropeller	HWX301030000006	✓	✓	n/a	n/a
		HWX301030000001	n/a	n/a	✓	✓
5	/	/	/	/	/	/
6	Motor Ventilator DC	HWX80200018	✓	✓	n/a	n/a
		HWX20000330132	n/a	n/a	✓	✓
7	Wicklung 16 A 50 Hz 5 mH	HWX82500020	✓	✓	n/a	n/a
	Wicklung 20 A 50 Hz 5.2 mH	HWX82500021	n/a	n/a	✓	✓
8	Linkes Schild	HWX80702123	✓	✓	n/a	n/a
		HWX80700244	n/a	n/a	✓	n/a
		HWX80702268	n/a	n/a	n/a	✓
9	Flügelevaporator	HWX80600042	✓	n/a	n/a	n/a
		HWX80600043	n/a	✓	n/a	n/a
		HWX80600044	n/a	n/a	✓	n/a
		HWX80600078	n/a	n/a	n/a	✓
10	Motorträger	HWX80700218	✓	✓	n/a	n/a
		HWX80700248	n/a	n/a	✓	n/a
		HWX80700329	n/a	n/a	n/a	✓
11	/	/	/	/	/	/
12	Obere Platte	HWX80900055	✓	✓	n/a	n/a
		HWX301090200806	n/a	n/a	✓	n/a
		HWX80900076	n/a	n/a	n/a	✓
13	/	/	/	/	/	/
14	/	/	/	/	/	/
15	Druckregler Niederdruck NO 0.30 MPa / 0.15 MPa	HWX20000360157	✓	✓	✓	✓
16	Druckanschluss 40 mm-1/2"	HWX20000140150	✓	✓	✓	✓
17	Druckregler Hochdruck NC 3.2 MPa/4.4 MPa	HWX20013605	✓	✓	✓	✓
18	Sensor des Wasserdurchsatzes	HWX83000068	✓	✓	✓	✓
19	T-Stecker Ø 6.5-2 x Ø 6.5(T) x 0.75	HWX20001460	✓	✓	✓	✓
20	Elektronischer Sensor	HWX81000011	✓	✓	n/a	n/a
		HWX81000013	n/a	n/a	✓	✓
21	T-Stecker Ø 9.52-2 x Ø 6.35(T) x 1.0	HWX304030000002	✓	✓	✓	✓
22	Filter Ø 9.7-Ø 9.7 (Ø19)	HWX20000140178	✓	✓	n/a	n/a
	Filter Ø 9.7-Ø 9.7 (Ø28)	HWX20041444	n/a	n/a	✓	✓
23	4-Wege-Ventil	HWX20041437	✓	✓	✓	✓
24	Stromanschlussklappe	HWX320922029	✓	✓	✓	✓
		HWX80700580	✓	✓	n/a	n/a
25	Rechtes Schild	HWX80700878	n/a	n/a	✓	n/a
		HWX80700581	n/a	n/a	n/a	✓
		HWX72300013	✓	n/a	n/a	n/a
26	Titan/PVC--Kondensator	HWX72300014	n/a	✓	n/a	n/a
		HWX72300010	n/a	n/a	✓	n/a
		HWX72300024	n/a	n/a	n/a	✓
27	/	/	/	/	/	/
28	Kompressor	HWX80100108	✓	✓	n/a	n/a
		HWX80100046	n/a	n/a	✓	✓

## 6. ANHANG (Fortsetzung)

HP5091DT3HA / HP5111DT3HA / HP5151DT3HA / HP5181DT3HA

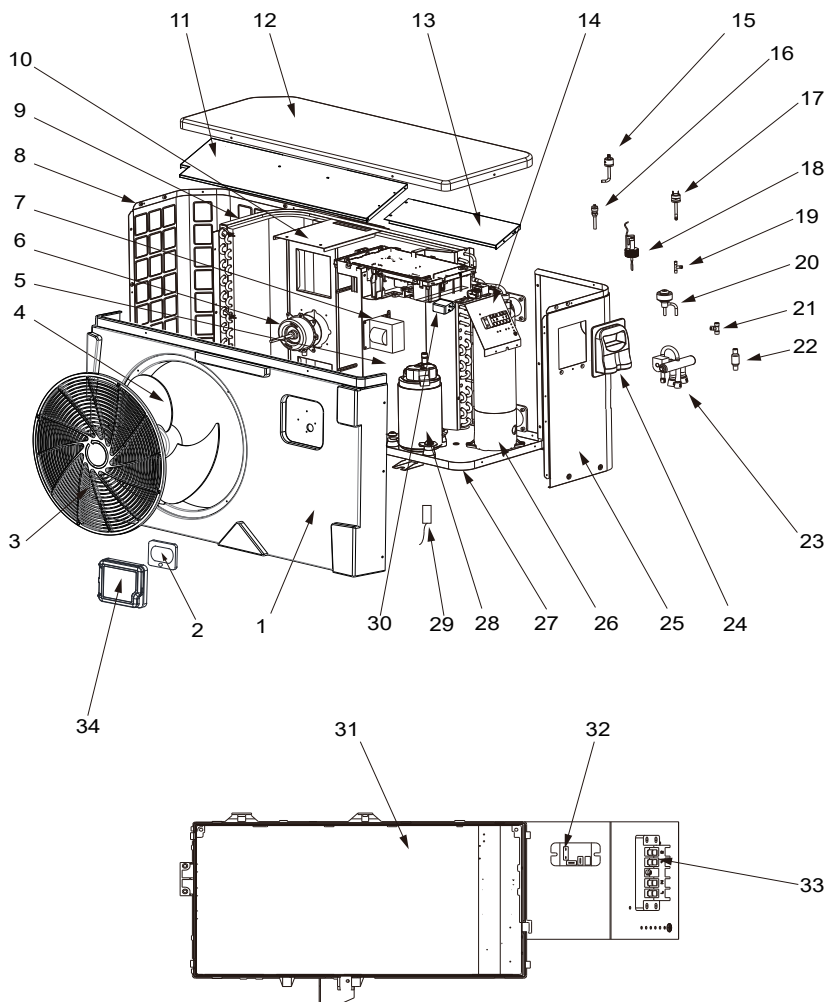

## 6. ANHANG (Fortsetzung)

Nr	Beschreibung	Ref.	HP5091DT3HA	HP5111DT3HA	HP5151DT3HA	HP5181DT3HA
29	Saugsonde des Kompressors 5 k - 560 mm	HWX83000044	✓	✓	n/a	n/a
	Saugsonde des Kompressors 5 k - 760 mm	HWX83000053	n/a	n/a	✓	✓
	Lufttemperatursensor 5 k - 350 mm	HWX83000049	✓	✓	✓	✓
	Sensor des Wasserauslasses 5 k - 410 mm	HWX83000050	✓	✓	✓	✓
	Sensor des Wassereinlasses 5 k - 850 mm	HWX83000052	✓	✓	✓	n/a
	Sensor des Wassereinlasses 5 k - 980 mm	HWX83000055	n/a	n/a	n/a	✓
	Abgabekompressorsensor 50 k - 660 mm	HWX83000026	✓	✓	✓	✓
	Abtausonde 5 k - 680 mm	HWX83000051	✓	✓	n/a	n/a
Abtausonde 5 k - 1040 mm	HWX83000045	✓	✓	✓	✓	
30	EMV-Filter	HWX20003257	n/a	n/a	✓	✓
31	Elektronische Treiberkarte	HWX72200168AP3	✓	n/a	n/a	n/a
		HWX72200168AP4	n/a	✓	n/a	n/a
		HWX72200167AP5	n/a	n/a	✓	n/a
		HWX72200167AP6	n/a	n/a	n/a	✓
32	Relais K2	HWX20000360297	✓	✓	✓	✓
33	Klemmleiste L-N-GND 5 Anschlüssen 4 mm <sup>2</sup>	HWX40003901	✓	✓	✓	✓
34	Schutztür	HWX80900321	✓	✓	✓	✓

## 6. ANHANG (Fortsetzung)

### 6.4 Anleitung zur Fehlerbehebung



**Manche Maßnahmen müssen von einem mit der Anlage vertrauten Techniker durchgeführt werden.**

Bei einem Fehler an der Wärmepumpe wird das Symbol  im oberen linken Ecke des Bildschirms angezeigt.

Im Falle einer Störung erscheinen die folgenden Anzeigen auf dem Bildschirm:



**Nach Behebung des Problems wird der Fehler automatisch quittiert, das Dreieck wird ausgeblendet.**

- Um die Fehlerliste zu löschen, auf  .
- Um zum Hauptbildschirm zurück zu kehren, drücken Sie 2 mal auf .

## 6. ANHANG (Fortsetzung)

Störung	Fehlercode	Beschreibung	Lösung
Ausfall des Sensors des Wassereinlasses	P01	Der Sensor ist offen oder kurzgeschlossen	Prüfen Sie die Verbindung CN21/RES1 auf der Karte und den Verlängerungsstecker oder tauschen Sie den Sensor aus.
Ausfall des Sensors des Wasserauslasses	P02		Prüfen Sie die Verbindung N22/RES2 auf der Karte und den Verlängerungsstecker oder tauschen Sie den Sensor aus.
Ausfall des Außentempersensors	P04		Prüfen Sie die Verbindung CN12/PH auf der Karte und den Verlängerungsstecker oder tauschen Sie den Sensor aus.
Ausfall des Magnetspulensensors	P05		Prüfen Sie die Verbindung CN8/OPT auf der Karte und den Verlängerungsstecker oder tauschen Sie den Sensor aus.
Fehler an der Saugsonde des Kompressors	P07		Prüfen Sie die Verbindung CN7/OAT auf der Karte und den Verlängerungsstecker oder tauschen Sie den Sensor aus.
Fehler Fördermengenfühler des Kompressors	P081		Prüfen Sie die Verbindung CN9/OHT auf der Karte und den Verlängerungsstecker oder tauschen Sie den Sensor aus.
Hochdruckregler	E01	Der Sensor ist offen oder kurzgeschlossen	Prüfen Sie die Verbindung CN30/HP an der Karte prüfen oder Sensor ersetzen.
			Wasserdurchfluss prüfen
			Wasserdurchflussmesser prüfen
			Öffnung der Ventile prüfen
			Druckausgleicher prüfen
			Verschmutzung des Verdampfers prüfen
			Wassertemperatur zu warm
			Problem von nicht kondensierbarem Material nach einer Wartung, Kältekreislaufs leeren und evakuieren.
Zu hohe Kältemittelfüllung, Flüssigkeit in eine Flasche ableiten.			
Niedrigdruckregler	E02	Der Sensor ist offen oder kurzgeschlossen	Den Anschluss AI/DI03 an der Karte prüfen oder Sensor ersetzen.
			Großes Kältemittelleck, Leck mit Detektor suchen
			Zu geringer Luftstrom, Drehzahl des Ventilators prüfen
			Verschmutzung des Verdampfers prüfen, dessen Oberfläche reinigen
Ausfall des Durchsatzsensors	E03	Der Sensor ist offen oder kurzgeschlossen	Den Anschluss AI/DI02 an der Karte prüfen oder Sensor ersetzen.
			Fehlendes Wasser, Funktion der Filterpumpe prüfen
			Öffnung der Absperrventile prüfen
			Einstellung des Druckausgleichers prüfen

## 6. ANHANG (Fortsetzung)

Störung	Fehlercode	Beschreibung	Lösung
Differenz Temperatur Eingang/ Ausgang > 13 °C	E06	Nur im Modus Kalt anwendbar	Fehlendes Wasser, Funktion der Filterpumpe prüfen
			Öffnung der Absperrventile prüfen
			Einstellung des Druckausgleichers prüfen
Frostschutz Frostmodus	E07	Temperatur Wasserausgang < 4 °C	Wärmepumpe stoppen, Kondensator leeren, Frostgefahr
Kommunikationsproblem	E08	Keine Kommunikation zwischen der elektronischen Karte und der Benutzeroberfläche	Prüfen Sie die Anschlüsse und die Verbindung – siehe Schaltschema
Frostschutz der Stufe 1	E19	2° < Wassertemperatur < 4° und Lufttemperatur < 0°	Den Betrieb der Wärmepumpe anhalten, den Kondensator leeren, um Frostbildung zu verhindern; standardmäßig startet die Wärmepumpe die Filterpumpe, um Frostbildung zu verhindern
Frostschutz der Stufe 2	E29	Wassertemperatur < 2° und Lufttemperatur < 0°	Den Betrieb der Wärmepumpe anhalten, den Kondensator leeren, um Frostbildung zu verhindern; standardmäßig startet die Wärmepumpe die Filterpumpe, um Frostbildung zu verhindern
Fehler des Gebläsemotors	F031	Blockierter Motor oder Anschlussfehler	Prüfen Sie die freie Drehung; prüfen Sie die Verbindung CN97/DCFan; tauschen Sie den Motor aus
Fehler des Gebläsemotors	F051	Anschlussfehler	Prüfen Sie die Verbindung DCFAN/CN97; tauschen Sie den Motor aus
Außentemperatur zu niedrig	TP	Betriebsgrenze erreicht	Schalten Sie die Wärmepumpe aus



## 6. ANHANG (Fortsetzung)

---

### 6.5 Garantie

#### GARANTIEVORAUSSETZUNGEN

Für sämtliche HAYWARD-Produkte bestehen innerhalb von zwei Jahren ab Kauf des Produkts Garantien hinsichtlich sämtlicher Fertigungsfehler oder Materialmängel. Bei jedem Antrag auf Garantie muss der Nachweis des Kaufs, einschließlich des Belegs zum Kaufdatum, erbracht werden. Wir bitten Sie also um Aufbewahrung Ihrer Rechnung.

Die HAYWARD-Garantie, die grundsätzlich ganz im Ermessen von HAYWARD liegt, beschränkt sich auf die Reparatur oder den Ersatz, hinsichtlich fehlerhafter Produkte, sofern sie sachgemäß benutzt wurden, nämlich in Übereinstimmung mit den im Benutzerleitfaden befindlichen Vorschriften; das Produkt darf keinesfalls verändert worden sein und darf ausschließlich mit den Bauteilen und Einzelteilen von HAYWARD benutzt werden. Die Garantie erstreckt sich nicht auf Beschädigungen aufgrund von Frost und Einwirkungen chemischer Substanzen.

Ausgeschlossen von der Garantie sind sämtliche sonstigen Kosten (Transport, Arbeitstätigkeit...).

HAYWARD kann nicht haftbar gemacht werden für direkte oder indirekte Schäden, die sich aufgrund falscher Montage, fehlerhaften Anschlusses oder der falschen Funktion des Produkts ergeben.

Falls Sie einen Garantieantrag stellen, eine Reparatur beantragen oder ein Produkt austauschen möchten, so wenden Sie sich bitte an Ihren Händler. Ausgeschlossen ist eine Material-Rücksendung an unser Werk ist ohne unsere vorherige schriftliche Zustimmung.

Die Verschleißteile unterliegen nicht der Garantie.

### 6.6 Entsorgung des ausgedienten Geräts



Die Kennzeichnung von Elektro- und Elektronikgeräten durch eine durchgestrichene Mülltonne weist darauf hin, dass diese Geräte nicht in normalem Hausmüll, Sperrmüll oder auf Mülldeponien entsorgt werden dürfen.

 Hat das Gerät sein Lebensende erreicht, so ist es in Hinblick auf Recycling oder Verwertung einer getrennten Abfallsammlung zuzuführen. In den Ländern der Europäischen Union und in Norwegen ist ein spezielles Abfallsammelsystem für Geräte dieser Art eingerichtet.

Zum Einsammeln, Zerlegen und Recycling dieses Geräts treten Sie bitte mit der Firma, die es installiert hat, oder der örtlichen Vertretung in Verbindung.

Die Aufbereitung des Kältemittels, des Öls und anderer Teile muss von einer hierzu nach geltenden lokalen und nationalen Vorschriften zugelassenen Fachkraft vorgenommen werden. Enthält das Gerät Batterien, die mit diesem Symbol gekennzeichnet sind, so können diese schädliche oder verschmutzende Stoffe enthalten. Die Batterien sind in diesem Fall bei einer Sammelstelle für verbrauchte Batterien abzugeben.

*Seite bewusst leer gelassen*



# HAYWARD<sup>®</sup>

## *FULL INVERTER*

ZWEMBAD WARMTEPOMP



HP5091DT3HA	HP5111DT3HA	HP5151DT3HA	HP5181DT3HA
-------------	-------------	-------------	-------------

**Installatie- en bedieningshandleiding**

# INHOUD

<b>1. ALGEMENE INSTRUCTIES - VEILIGHEID</b>	<b>1</b>
<b>2. TECHNISCHE EIGENSCHAPPEN</b>	<b>5</b>
2.1 Technische gegevens over de warmtepomp	5
2.2 Werkgebied	6
2.3 Afmetingen	7
<b>3. INSTALLATIE EN AANSLUITING</b>	<b>8</b>
3.1 Basisschema	8
3.2 Warmtepomp	8
3.3 Hydraulische aansluiting	10
3.4 Elektrische aansluiting	11
3.5 Eerste gebruik	12
3.6 Instelling van het waterdebiet	14
<b>4. GEBRUIKERSINTERFACE</b>	<b>15</b>
4.1 Algemene voorstelling	15
4.2 Instelling Datum en Tijd	17
4.3 De timers aan/uit instellen	18
4.4 Instelwaarde aanpassen	20
4.5 Het touchscreen vergrendelen en ontgrendelen.	21
4.6 Instellen van de SILENCE functie	22
<b>5. ONDERHOUD EN OVERWINTERING</b>	<b>25</b>
5.1 Onderhoud	25
5.2 Overwintering	25
<b>6. BIJLAGEN</b>	<b>26</b>
6.1 Elektrische schema's	26
6.2 Aansluitingen prioriteit verwarming eenfasepomp	28
6.3 Opengewerkte tekeningen en onderdelen	30
6.4 Gids voor het probleemoplossing	34
6.5 Garantie	37
6.6 Einde levensduur van het toestel	37

Aandachtig lezen en bewaren voor later gebruik.

Dit document moet aan de eigenaar van het zwebad overhandigd en door hem op een veilige plaats bewaard worden.

# 1. ALGEMENE INSTRUCTIES - VEILIGHEID

---

Hartelijk dank voor de aanschaf van deze Hayward zwembadwarmtepomp. De Hayward FULL INVERTER warmtepomp is ontworpen volgens strenge productienormen om te voldoen aan de hoogste kwaliteitseisen.

De Hayward warmtepompen bieden u uitzonderlijke prestaties terwijl gedurende het hele zwemseizoen door het vermogen, het elektriciteitsverbruik en het geluidsniveau aan te passen aan de verwarming van uw zwembad dankzij de FULL INVERTER-besturingslogica.



***Lees de instructies in deze handleiding zorgvuldig door voordat u het apparaat in gebruik neemt.***

Deze handleiding bevat alle noodzakelijke informatie over installatie, probleemoplossing en onderhoud.

Lees deze handleiding zorgvuldig door voordat u het apparaat opent of onderhoudswerkzaamheden aan het apparaat uitvoert. De fabrikant van dit product is in geen geval aansprakelijk voor enig letsel van een gebruiker of schade aan het apparaat als gevolg van mogelijke fouten tijdens de installatie, het verhelpen van storingen of onnodig onderhoud. Het is van essentieel belang om de instructies in deze handleiding te allen tijde op te volgen.

Nadat u deze handleiding gelezen hebt, bewaar deze dan voor eventueel later gebruik.

## **Bevoegd personeel**

- De installatie, de elektrische aansluitingen, het onderhoud en de reparaties van het toestel moeten worden uitgevoerd door een erkend vakman overeenkomstig de voorschriften en beste praktijken die gelden in het land waar het toestel wordt geïnstalleerd (zie § 3.4).  
Voor elke interventie op het koelcircuit moet de installateur beschikken over een certificaat van bekwaamheid om met koelmiddelen om te gaan.  
Voor Frankrijk:
  - Laagspanningsinstallatie volgens NF-C 15-100.
  - Wetgeving inzake de behandeling van koelmiddelen: Besluit 2007/737 en de uitvoeringsbesluiten daarvan.

# 1. ALGEMENE INSTRUCTIES - VEILIGHEID (vervolg)

## Dit product bevat R32 koelgas



*Dit apparaat bevat R32.*

***Gebruik nooit een ander koelmiddel dan R32. Elk ander gasvormig lichaam vermengd met de R32 kan abnormaal hoge drukken veroorzaken die kunnen leiden tot breuken in leidingen en/of persoonlijk letsel.***

***Gebruik voor reparaties of onderhoud koperen buizen die voldoen aan de norm NF EN 12375-1 en de Europese Richtlijn drukapparatuur 97/23/EG.***

***Omdat de warmtepomp onder druk staat, mag u nooit gaten boren in de leidingen of proberen deze te solderen. Er bestaat explosiegevaar.***

***Stel het apparaat nooit bloot aan vlammen, vonken of andere ontstekingsbronnen. Het kan ontploffen en ernstige of zelfs dodelijke verwondingen veroorzaken.***

***Gebruik voor het opsporen van lekkage van koelmiddelen geen lekzoeklamp of een andere detector met open vlam. Gebruik NOOIT potentiële ontstekingsbronnen.***

Dit product bevat gefluoreerde broeikasgassen vastgelegd door het Kyoto-protocol. Laat deze gassen niet in de atmosfeer vrijkomen.

GWP-waarde<sup>(1)</sup>: 675, waarde gebaseerd op het 4e GIEC-rapport.

Beveiligingsgroep: A2L.

De hoeveelheid koudemiddel op basis van de F Gas 517/2014 regeling staat aangegeven op het typeplaatje van het apparaat.

Alle interventies op het koelcircuit moeten, zoals eerder vermeld, worden uitgevoerd door een erkend vakman.

Afhankelijk van de Europese of lokale wetgeving, moet regelmatig op koelmiddellekken gecontroleerd worden. Gelieve uw plaatselijke distributeur te contacteren voor meer informatie.

- Let op: koelmiddelen kunnen geurloos zijn.
- Doorboor of verhit de leidingen niet! Er bestaat risico op explosie en ernstige brandwonden.
- Gebruik alleen door de fabrikant aanbevolen middelen om het ontdooiingsproces of de reiniging te versnellen.
- Sla het toestel NIET op in een ruimte met continu werkende ontstekingsbronnen (zoals open vuur, gasapparaten of elektrische kachels).

(1) Aardopwarmingspotentieel

# 1. ALGEMENE INSTRUCTIES - VEILIGHEID (vervolg)

## Voorwaarden voor installatie

- Deze warmtepomp is uitsluitend bedoeld voor het verwarmen van zwembadwater, gebruik deze apparatuur niet voor andere doeleinden.
- Probeer dit toestel niet zelf te installeren.
- Als u een defect of een abnormale situatie constateert, stop dan de installatie van de warmtepomp en neem onmiddellijk contact op met uw dealer.
- In geval van opslag moet de warmtepomp worden opgeslagen in een goed geventileerde ruimte met een vloeroppervlakte van meer dan  $A_{\min}$  (m<sup>2</sup>) volgens de volgende formule:  $A_{\min} = (M / (2,5 \times 0,22759 \times h_0))^2$   
M is de koelmiddelvulling in het apparaat in kg en h<sub>0</sub> is de opslaghoogte.  
Voor grondopslag h<sub>0</sub> = 0,6 m.
- Dit product is uitsluitend ontworpen voor huiselijk gebruik en installatie buitenshuis. De lucht die uit het product ontsnapt, moet vrij kunnen stromen en mag niet worden gebruikt voor andere doeleinden, zoals het verwarmen of koelen van een ruimte of gebouw.
- Controleer de voedingskabel. Als de voedingskabel beschadigd is, moet deze worden vervangen door de fabrikant, zijn servicedienst of een bevoegd persoon.
- De aansluiting van het apparaat op de aarde en de continuïteit ervan zijn verplicht. De aardingskabel moet langer zijn dan de andere kabels om het risico van een elektrische schok te voorkomen als de kabel wordt losgetrokken. De elektrische installatie moet voorzien zijn van een differentiaalbeveiliging van 30 mA (cf § 3.4).
- Controleer of de bijgeleverde beugel voor het apparaat de juiste maat heeft voor het gewicht van het apparaat.
- **Elke aanbeveling die niet wordt opgevolgd, maakt de garantie ongeldig.**

## Instructies voor onderhoud

1 keer per jaar moeten er onderhoudswerken plaatsvinden om de levensduur en een goede werking van de warmtepomp te kunnen garanderen.

- Het onderhoud en de bediening dient uitgevoerd te worden volgens de in deze handleiding opgegeven aanbevolen tijden en frekwenties.
- Gebruik uitsluitend originele wisselstukken.
- Controleer de voedingskabel. Als de voedingskabel beschadigd is, moet deze worden vervangen door de fabrikant, zijn servicedienst of een bevoegd persoon.
- Controleer de aansluiting van het toestel op de aarde en de continuïteit ervan.
- Poets de verdamper met een zachte borstel, een luchtstraal of met water.  
**Opgelet, gebruik nooit een hogedrukreiniger.**

# 1. ALGEMENE INSTRUCTIES - VEILIGHEID (vervolg)

- Controleer of de condensaten goed afgevoerd worden.
- Controleer of de elektrische en hydraulische aansluitingen goed afsluiten.
- Controleer de hydraulische dichting van de condensor.
- De waterdichtheid van het koelcircuit **door een erkende professional** laten controleren met een lekdetector.



***Voor ieder onderhoud moet de warmtepomp ontkoppeld worden van elke elektrische bron. Onderhoud mag enkel door een gekwalificeerde en bevoegde installateur gebeuren die gewend is met koelmiddelen om te gaan.***

## Instructies voor overwintering

- Zet de warmtepomp in Modus "OFF".
- Ontkoppel de voeding van de warmtepomp.
- Maak de condensor leeg met behulp van de aflatopening om schade te vermijden. (belangrijk risico bij bevroering).
- Sluit de "by-pass"-klep af en schroef de aansluitingen op de in-/uitlaat los.
- Voer het resterende water in de condensor door middel van een luchtpistool af.
- Sluit de watertoevoer en -afvoer van de warmtepomp af om te vermijden dat vreemde voorwerpen binnendringen.
- Bedek de warmtepomp met de meegeleverde overwinteringshoes.



***Eender welke schade veroorzaakt door een slechte overwintering, zorgt ervoor dat de garantie geannuleerd wordt.***

## Gebruiksvoorwaarden

Dit toestel kan worden gebruikt door kinderen vanaf 8 jaar oud en door personen met beperkte lichamelijke, zintuiglijke of geestelijke vermogens, of met gebrek aan ervaring of kennis, indien zij onder adequaat toezicht staan of indien zij instructies hebben gekregen over het veilige gebruik van het toestel en de daaraan verbonden risico's hebben begrepen.

Laat kinderen niet met het toestel spelen.

Reiniging en onderhoud door de gebruiker mogen niet worden uitgevoerd door kinderen zonder toezicht.



## 2. TECHNISCHE EIGENSCHAPPEN

### 2.1 Technische gegevens over de warmtepomp

Modellen	FULL INVERTER	HP5091DT3HA	HP5111DT3HA	HP5151DT3HA	HP5181DT3HA
Voedingsspanning	V	220V-240V ~ / 1ph / 50Hz			
Koelmiddel	/	R32			
Belasting	kg	0,430	0,450	0,60	0,670
Massa in TCO <sub>2</sub>	/	0,29	0,30	0,41	0,45
Frequentie van de controle op lekkage	/	Geen eisen, maar jaarlijks geadviseerd			
Verwarmingcapaciteit Min--Max <sup>(a)</sup>	kW	2,46 -- 9,17	2,36 -- 11,45	3,31 -- 15,90	3,2 -- 18,15
Opgenomen elektrisch vermogen Min--Max <sup>(a)</sup>	kW	0,17 -- 1,45	0,17 -- 1,80	0,27 -- 2,84	0,22 -- 3,13
Nominale bedrijfsstroom Min--Max <sup>(a)</sup>	A	1,17 -- 6,42	1,19 -- 7,85	1,37 -- 12,35	1,45 -- 13,58
COP Max--Min <sup>(a)</sup>	/	14,37 -- 6,32	13,88 -- 6,35	12,26 -- 5,59	14,34 -- 5,80
Verwarmingcapaciteit Min--Max <sup>(b)</sup>	kW	1,75 -- 7,05	1,56 -- 8,00	3,05 -- 12,40	2,86 -- 14,11
Opgenomen elektrisch vermogen Min--Max <sup>(b)</sup>	kW	0,27 -- 1,51	0,279 -- 1,74	0,42 -- 2,65	0,43 -- 2,99
COP Max--Min <sup>(b)</sup>	/	6,40 -- 4,65	5,60 -- 4,80	7,26 -- 4,68	6,63 -- 4,71
Maximale bedrijfsstroom (MBS)	A	8,40	9,50	14	15,9
Vermogen van de zekering	A/m	10	12	16	20
D-curve stroomonderbreker	D	10	12	16	20
Startstroom	A	< MBS			
Hydraulische aansluiting	mm	50 mm			
Nominaal waterdebiet <sup>(a)</sup>	m <sup>3</sup> /h	4,00	5,00	6,70	7,70
Max. waterdrukverlies	kPa	3,80	4,0	6,3	10
Compressor	/	DC Inverter Panasonic		DC Inverter Mitsubishi	
Type	/	Dubbele roterende		Dubbele roterende	
Hoeveelheid	/	1			
Wikkelweerstand bij 20°C	Ohm	1,208		0,95	
Ventilator	/	Axiaal			
Hoeveelheid		1			
Diameter	mm	405		510	
Aantal bladen	/	3			
Motor	/	DC-omvormer			
Hoeveelheid	/	1			
Rotatiesnelheid	Tr/min	400 -- 700	500 -- 850	300 -- 750	400 -- 750
Snelheid Stille modus	Tr/min	400	500	300	400
Geluidsdrukkniveau op 1 m	dB(A)	50,2	53,9	50,8	54,0
Geluidsdrukkniveau op 10 m	dB(A)	32,8	34,2	33,8	37,25
Netto afmetingen van de eenheid (B-I-H)	mm	1003 / 418 / 605		1048 / 437 / 768	1161 / 473 / 862
Gewicht	kg	44	45	66	70

(a) Droge lucht 27°C - Relatieve vochtigheid 78% - Watertoevoertemperatuur 26°C.



(b) Droge lucht 15°C - Relatieve vochtigheid 71% - Watertoevoertemperatuur 26°C

## 2. TECHNISCHE EIGENSCHAPPEN (vervolg)

---

### 2.2 Werkgebied

Gebruik de warmtepomp in volgende temperatuur- en vochtigheidsbereiken om een correct en efficiënt te garanderen.

	Verwarmingsmodus 	Afkoelingsmodus 
Buitentemperatuur	-7°C – +35°C	+7°C – +43°C
Watertemperatuur	+12°C – +32°C	+8°C – +40°C
Relatieve vochtigheid	< 80%	< 80%
Instelbereik van de gewenste waarde	+15°C – +32°C	+8°C – +32°C



***Als de temperatuur of de vochtigheid niet aan deze voorwaarden voldoet, kunnen beveiligingen losraken en kan de warmtepomp niet meer werken.***



***De maximale verwarmingstemperatuur is 32°C om beschadiging van de liners te voorkomen. Hayward wijst alle aansprakelijkheid af in geval van gebruik boven 32°C.***

## 2. TECHNISCHE EIGENSCHAPPEN (vervolg)

### 2.3 Afmetingen

Modellen :

HP5091DT3HA / HP5111DT3HA / HP5151DT3HA / HP5181DT3HA

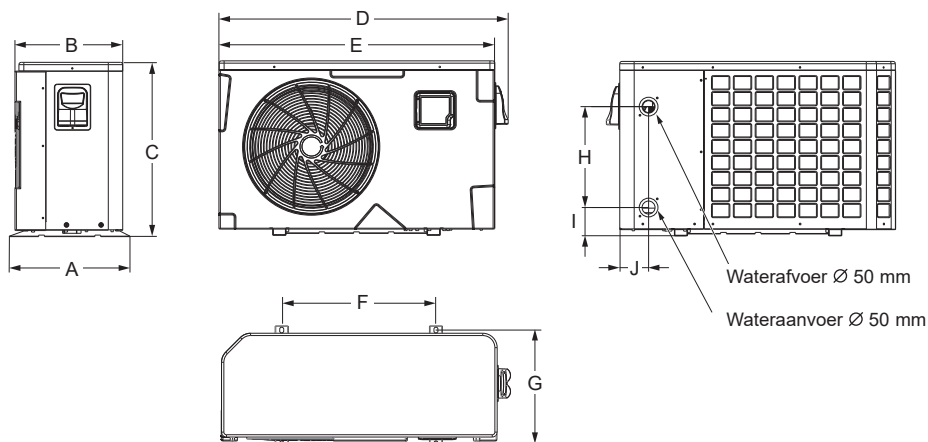

Unit : mm

Merktken	Modell	HP5091DT3HA / HP5111DT3HA	HP5151DT3HA	HP5181DT3HA
	<b>A</b>		418	436,5
<b>B</b>		374	418	451,5
<b>C</b>		604,5	767,5	862
<b>D</b>		1003	1047,5	1160,5
<b>E</b>		956	1002	1115
<b>F</b>		535	615	790
<b>G</b>		394,5	410	447
<b>H</b>		350	350	466
<b>I</b>		97,7	101,2	97,6
<b>J</b>		99,2	106,5	113,5

## 3. INSTALLATIE EN AANSLUITING

### 3.1 Basisschema

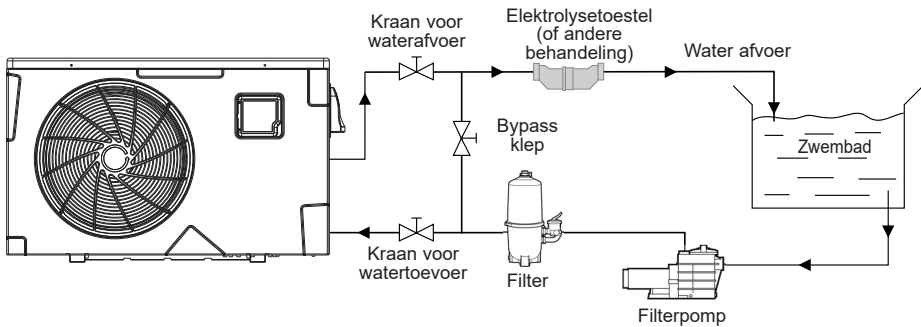

Opmerking : Met de warmtepomp wordt geen randapparatuur of filter meegeveleverd. De onderdelen op het schema moeten door de installateur voorzien worden.

### 3.2 Warmtepomp



**Plaats de pomp en openlucht en buiten een gesloten technisch lokaal. Kies een plaats die bij voorkeur zonnig is en beschermt tegen harde wind. Het toestel moet gemakkelijk toegankelijk zijn voor latere installatie- en onderhoudswerkzaamheden. De installatie moet beschermt staan en de hieronder voorgeschreven minimumafstanden moeten gerespecteerd worden om luchtterugvoer en een minder goede werking van de warmtepomp te voorkomen**

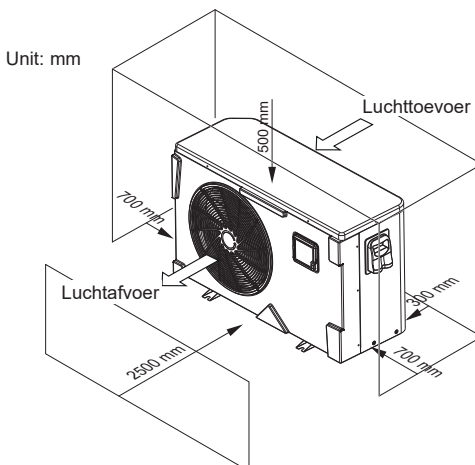

### 3. INSTALLATIE EN AANSLUITING (vervolg)



**Plaats het toestel niet rechtstreeks op de vloer omdat dit storingen kan veroorzaken.**

**Plaats het toestel bij voorkeur op de vloer op anti-trillingsmatten.**

**Gebruik geen muurbevestiging in omstandigheden waarin trillingen kunnen worden doorgegeven.**

**Installeer de warmtepomp niet op een steun die de trillingen van het apparaat kan versterken.**

**Installeer de warmtepomp niet op een plaats waar het geluidsniveau kan worden versterkt of op een plaats waar het geluid van het apparaat de buurt kan verstoren.**

**Gebruik geen lijm: dit wordt niet beschouwd als een betrouwbaar bevestigingsmiddel.**

**Installeer de warmtepomp bij voorkeur op een vlakke, niet gekoppelde betonplaat (bijgeleverde schroeven en ringen).**

**Bevestig het toestel met het voorgeschreven aanhaalmoment om elk risico op ongevallen of schade aan apparatuur en personen te voorkomen.**

**Als alternatief kan de warmtepomp met behulp van geschikte moeren (niet meegeleverd) op rubberen vloersteunen worden geïnstalleerd.**

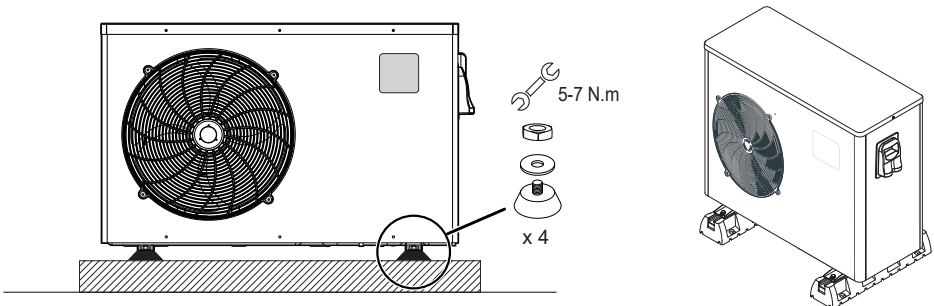

**De maximumafstand tussen de warmtepomp en het zwembad is 15 meter.**

**De totale lengte van de hydraulische leidingen is 30 meter.**

**De bovengrondse en ondergrondse hydraulische kanalen isoleren.**

**De warmtepomp moet op een minimum afstand van het bassin worden geïnstalleerd conform de NF C 15-100 (dat wil zeggen op 3,5 m van het waterbassin voor Frankrijk) of conform de geldende installatienormen in andere landen.**

**Installeer de waterpomp niet in de buurt van een warmtebron.**

**In geval van installatie in regio's waar het geregeld sneeuwt, wordt aangeraden het apparaat overdekt te installeren om te voorkomen dat er zich sneeuw op de verdampers opstapelt.**

## 3. INSTALLATIE EN AANSLUITING (vervolg)

---

### 3.3 Hydraulische aansluiting

De warmtepomp is voorzien van 2 aansluitingen met een diameter van 50 mm. Gebruik PVC-buizen voor de hydraulische leidingen Ø 50 mm. Sluit de watertoevoer van de warmtepomp op de leiding die van de filtergroep komt en sluit daarna de waterafvoer van de warmtepomp op de waterleiding die naar het zwembad loopt (cv tekening hieronder).

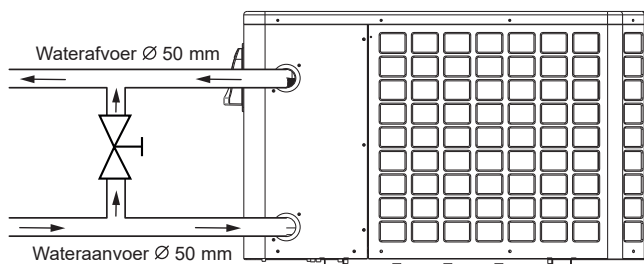

Installeer een bypassklep tussen de in- en uitgang van de warmtepomp.



***Als u een automatische distributeur of een elektrolyseapparaat gebruikt, moet deze na de warmtepomp geïnstalleerd worden om de Titanium condensor tegen een te hoge concentratie aan chemische producten te beschermen.***



***Zorg ervoor dat de bypassklep en de aansluitingen op de aan- en afvoer van het water goed geïnstalleerd zijn om de drainage tijdens de winterperiode, de toegang en de demontage voor onderhoud te vergemakkelijken.***

### 3. INSTALLATIE EN AANSLUITING (vervolg)

#### 3.4 Elektrische aansluiting



**De elektrische installatie en de bekabeling van deze uitrusting moeten conform zijn met de plaatselijk geldende normen.**

F	NF C15-100	GB	BS7671:1992
D	DIN VDE 0100-702	EW	EVHS-HD 384-7-702
A	ÖVE 8001-4-702	H	MSZ 2364-702/1994/MSZ 10-553 1/1990
E	UNE 20460-7-702 1993, RECBT ITC-BT-31 2002	M	MSA HD 384-7-702.S2
IRL	Wiring Rules + IS HD 384-7-702	PL	PN-IEC 60364-7-702:1999
I	CEI 64-8/7	CZ	CSN 33 2000 7-702
LUX	384-7.702 S2	SK	STN 33 2000-7-702
NL	NEN 1010-7-702	SLO	SIST HD 384-7-702.S2
P	RSIUEE	TR	TS IEC 60364-7-702



**Controleer of de elektrische voeding en de netwerkfrequentie overeenstemmen met de vereiste werkstroom, door rekening te houden met de specifieke plaatsing van het toestel en de noodzakelijke stroom om alle andere toestellen die op hetzelfde circuit aangesloten zijn, te voeden.**

**HP5091DT3HA / HP5111DT3HA / HP5151DT3HA / HP5181DT3HA  
230V ~ +/- 10 % 50 Hz 1 Fase**

**Bestudeer het overeenkomstige bedradingschema in bijlage.  
De aansluitdoos bevindt zich aan de rechterkant van de eenheid. Drie connecties zijn voor de elektrische voeding en twee voor de besturing van de warmtepomp (Bediening).**

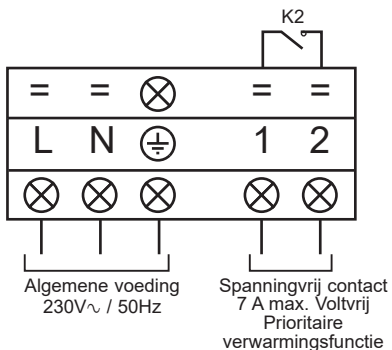

### 3. INSTALLATIE EN AANSLUITING (vervolg)

---



**Gebruik nooit een stopcontact voor de stroomvoorziening. De stroomvoorziening moet naar behoren worden uitgerust met een omnipolaire beveiligingsinrichting van het D-curve type onderbreker en een 30mA differentieelschakelaar (zie tabel hieronder).**

Modellen		HP5091DT3HA	HP5111DT3HA	HP5151DT3HA	HP5181DT3HA
Elektrische voeding	V/Ph/Hz	230V~ 50Hz	230V~ 50Hz	230V~ 50Hz	230V~ 50Hz
Stroomonderbreker met D-curve	A	8 D	10 D	16 D	20 D
Kabelsectie	mm <sup>2</sup>	3G 2,5	3G 2,5	3G 2,5	3G 4



**Gebruik een voedingskabel van het type RO 2V / R 2V of equivalent.**



**De kabelsecties worden gegeven voor een maximale lengte van 25 m. Deze moeten echter worden gecontroleerd en aangepast afhankelijk van de installatieomstandigheden.**



**Schakel altijd de hoofdschakelaar uit alvorens de elektriciteitsdoos te openen. Wacht na het uitschakelen van de stroomvoorziening 10 minuten voordat u zich toegang verschafft tot de interne actieve onderdelen van het toestel (in de condensatoren opgeslagen energie).**

#### 3.5 Eerste gebruik

Opstartprocedure - zodra de installatie beëindigd is, moet u de volgende stappen volgen en respecteren :

- 1) Draai de ventilatoren handmatig om te controleren of deze met de hand gedraaid kunnen worden en of het blad op de motorboom bevestigd is.
- 2) Controleer of de eenheid correct op de hoofdvoeding aangesloten is (zie bedradingsschema in bijlage).
- 3) Activeer de filterpomp.
- 4) Controleer of alle waterkleppen openstaan en dat het water naar de eenheid loopt alvorens in verwarming of koeling opstart.
- 5) Controleer of de drainageleiding correct vastgemaakt is en niet verstopt is.
- 6) Schakel de elektrische voeding van de eenheid in en druk daarna op de Start/Stop-knop  op het controlepaneel.



### 3. INSTALLATIE EN AANSLUITING (vervolg)

---

- 7) Zorg ervoor dat de alarm- of vergrendelingsymbolen niet verschijnen. Raadpleeg, indien nodig, de gids voor het oplossen van problemen (zie § 6.4).
- 8) Leg het waterdebiet vast met behulp van de bypassklep (zie § 3.6 en 2.1), zoals respectievelijk vastgelegd is voor ieder model, zodat er een temperatuurverschil van 2°C is tussen het Binnenkomend en Uitgaand water.
- 9) Wanneer het toestel enkele minuten gedraaid heeft, controleer dan dat de lucht die eruit komt, afgekoeld is (tussen 5° en 10°).
- 10) Stop de filterpomp terwijl de eenheid blijft draaien. De eenheid moet automatisch stoppen en de foutcode E03 weergeven.
- 11) Laat de eenheid en de zwembadpomp 24u op 24u draaien todat de gewenste watertemperatuur bereikt is. Wanneer het binnenkomend water de gewenste temperatuur bereikt heeft, zal de eenheid stilvallen. Ze zal automatisch opstarten (als de zwembadpomp in werking is) als de temperatuur van het zwembad 0.5°C lager is dan de gewenste temperatuur.

**Debietschakelaar** - De eenheid is voorzien van een debietschakelaar die de warmtepomp inschakelt wanneer de filterpomp van het zwembad in werking is, en uitschakelt wanneer de de filterpomp stopt. Bij onvoldoende water zal de alarmcode E03 op de schakelaar getoond worden (Zie § 6.4).

**Vertraging** - De eenheid vertoont een vertraging van 3 minuten om de onderdelen van het besturingscircuit te beschermen en om onregelmatige opstart en storingen van de contactor te vermijden. Dankzij deze vertraging start de eenheid automatisch op ongeveer 3 minuten na een stroomonderbreking. Zelfs een korte stroomonderbreking zal de uitgestelde start activeren.

## 3. INSTALLATIE EN AANSLUITING (vervolg)

---

### 3.6 Instelling van het waterdebiet

Terwijl de kleppen voor binnenkomend en uitgaand water openstaan, moet u de bypassklep afstellen om een temperatuurverschil van 2°C tussen het binnenkomend en uitgaand water te bekomen (zie basisschema §3.1). U kan de instelling controleren voor de temperaturen van het binnenkomend en uitgaand water te visualiseren op het controlepaneel.



Opmerking : De opening van de bypassklep zorgt voor een lager waterdebiet.  
De sluiting van de bypassklep zorgt voor een hoger waterdebiet

## 4. GEBRUIKERSINTERFACE

### 4.1 Algemene voorstelling

De warmtepomp is uitgerust met een digitaal besturingspaneel met touchscreen, elektrisch aangesloten en voorgeïnstalleerd in verwarmingsmodus.

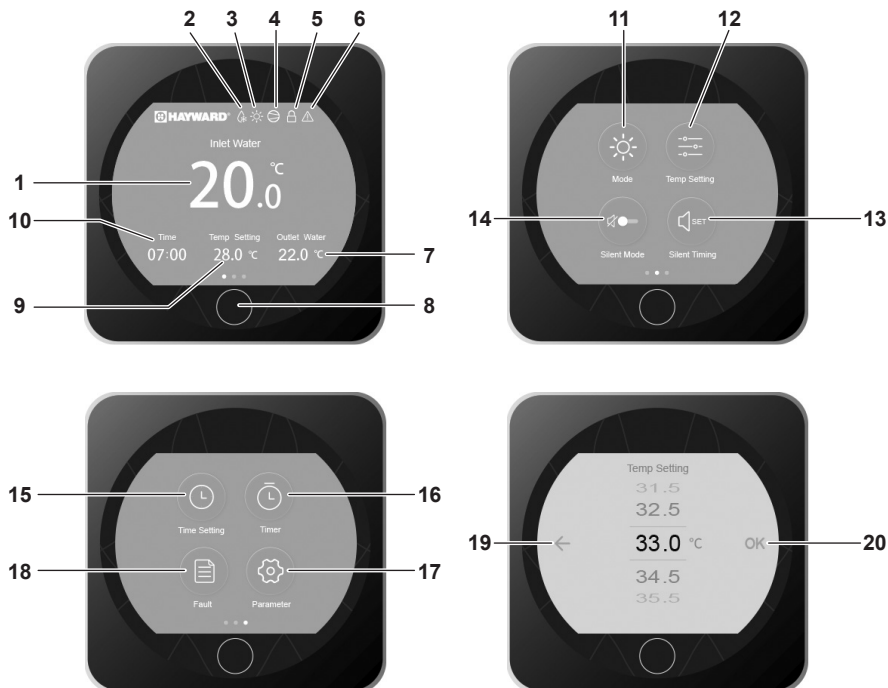

### Legende

1	Temperatuur wateraanvoer
2	Modus de-icing
3	Werkwijze
4	Indicatielampje voor de werking van de compressor
5	Het scherm vergrendelen
6	Alarm
7	Temperatuur waterafvoer
8	Aan/uit/terug
9	Gewenste temperatuur
10	Tijd

11	Selectie van de werkingsmodus
12	Instelwaarde aanpassen
13	Instelling timer stille modus
14	Stille modus inschakelen
15	Datum en tijd instellen
16	Timers aan/uit instellen
17	Geavanceerde instellingen
18	Lijst met defecten
19	Terug (zonder bevestiging)
20	Bevestiging

## 4. GEBRUIKERSINTERFACE (vervolg)

---

### OFF/STOP-modus

Wanneer de warmtepomp wordt uitgeschakeld (in standby-modus), verschijnt het label OFF op het display.

Een zwarte display geeft aan dat de warmtepomp gestopt is, in deze modus is het mogelijk om parameters in te stellen.



### ON/BEDRIJFS-modus

Wanneer de warmtepomp in bedrijf is of in een ingestelde stand staat (het bereiken van de ingestelde waarde), wordt het display blauw.



Om over te schakelen van OFF naar ON modus en vice versa, drukt u op de  knop.

## 4. GEBRUIKERSINTERFACE (vervolg)

### 4.2 Instelling Datum en Tijd

De datum en tijd voor de ON of OFF modus kunnen worden ingesteld.

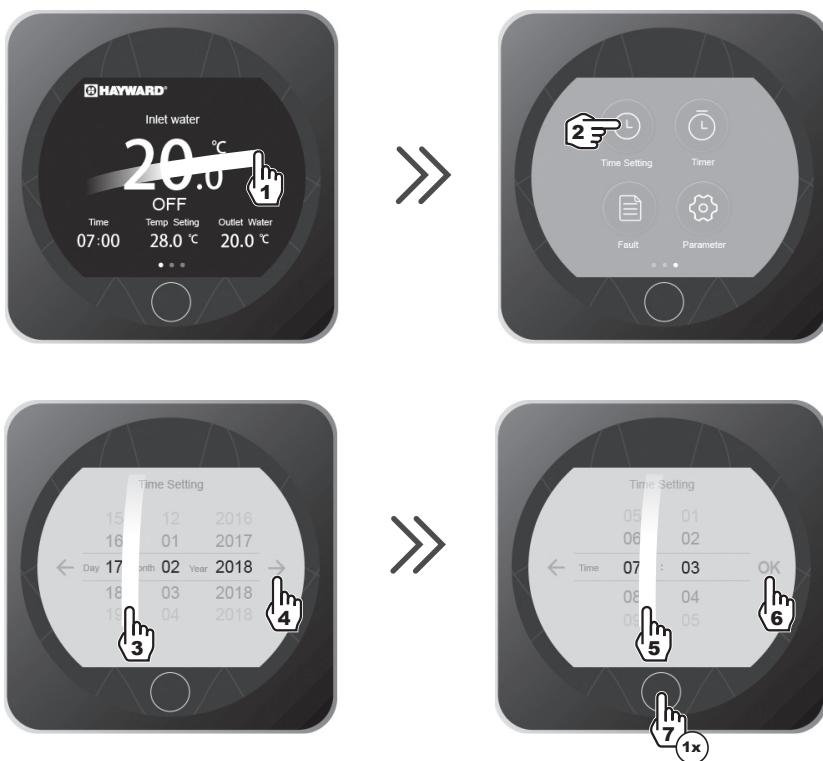

- Druk 1 maal op  op om terug te keren naar het hoofdscherm.

## 4. GEBRUIKERSINTERFACE (vervolg)

### 4.3 De timers aan/uit instellen

De instellingen van deze functie zijn noodzakelijk zodra u uw warmtepomp binnen een kortere termijn dan vastgelegd door de filterklok wilt gebruiken. Op die manier kunt u een uitgestelde start en een vroegtijdige uitschakeling programmeren of eenvoudigweg een periode waarin de pomp niet gebruikt mag worden.

U kunt een timer Start en een timer Stop programmeren.  
Het instellingsinterval is van «van uur tot uur».



## 4. GEBRUIKERSINTERFACE (vervolg)

---



**Helder blauw = Geactiveerd**  
**Grijs = gedeactiveerd**

- Druk 2 maal op  op om terug te keren naar het hoofdscherm.

## 4. GEBRUIKERSINTERFACE (vervolg)

### 4.4 Instelwaarde aanpassen

De instelling van de instelwaarde kan in de AAN- of UIT-stand worden uitgevoerd met een nauwkeurigheid van 0,5°C.



- Druk 1 maal op  op om terug te keren naar het hoofdscherm.



**Het is aangewezen nooit de 30°C te overschrijden om te vermijden dat de liners verkleuren.**



## 4. GEBRUIKERSINTERFACE (vervolg)

### 4.5 Het touchscreen vergrendelen en ontgrendelen.

Het scherm kan worden vergrendeld en ontgrendeld in de ON of OFF modus.



Vergrendeling ingeschakeld



Vergrendeling uitgeschakeld

## 4. GEBRUIKERSINTERFACE (vervolg)

### 4.6 Instellen van de SILENCE functie

In de stille modus werkt de warmtepomp in de economische modus en heel stil als de verwarmingsbehoefte laag is (handhaven van de temperatuur van het bassin of indien een ultrastille werking nodig is).

Deze functie kan zowel handmatig als met behulp van een timer geactiveerd/gedeactiveerd worden.

#### Inschakelen / Uitschakelen



Stille modus uitgeschakeld



Stille modus geactiveerd



- Druk 1 maal op  op om terug te keren naar het hoofdscherm.

## 4. GEBRUIKERSINTERFACE (vervolg)

---

De timer voor de STILLE-modus instellen



## 4. GEBRUIKERSINTERFACE (vervolg)

---



- Druk 2 maal op  op om terug te keren naar het hoofdscherm.



**Het instellingsinterval is van «van uur tot uur».**  
**Als de Timer is geactiveerd, is deze 7 dagen per week actief.**

## 5. ONDERHOUD EN OVERWINTERING

---

### 5.1 Onderhoud

1 keer per jaar moeten er onderhoudswerken plaatsvinden om de levensduur en een goede werking van de warmtepomp te kunnen garanderen.

- Het onderhoud en de reparaties van het toestel moeten worden uitgevoerd door een erkend vakman overeenkomstig de voorschriften en beste praktijken die gelden in het land waar het toestel wordt geïnstalleerd (zie § 3.4). Voor elke interventie op het koelcircuit moet de installateur beschikken over een certificaat van bekwaamheid om met koelmiddelen om te gaan.
- Controleer de voedingskabel. Als de voedingskabel beschadigd is, moet deze worden vervangen door de fabrikant, zijn servicedienst of een bevoegd persoon.
- Controleer de aansluiting van het toestel op de aarde en de continuïteit ervan.
- Poets de verdamper met een zachte borstel, een luchtstraal of met water **Opgelet, gebruik nooit een hogedrukreiniger**).
- Controleer of de condensaten goed afgevoerd worden.
- Controleer of de elektrische en hydraulische aansluitingen goed afsluiten.
- Controleer de hydraulische dichting van de condensor.
- De waterdichtheid van het koelcircuit **door een erkende professional** laten controleren met een lekdetector.



***Voor ieder onderhoud moet de warmtepomp ontkoppeld worden van elke elektrische bron. Onderhoud mag enkel door een gekwalificeerde en bevoegde installateur gebeuren die gewend is met koelmiddelen om te gaan.***

### 5.2 Overwintering

- Zet de warmtepomp in Modus "OFF".
- Ontkoppel de voeding van de warmtepomp.
- Maak de condensor leeg met behulp van de aflaatopening om schade te vermijden. (belangrijk risico bij bevriezing).
- Sluit de "by-pass"-klep af en schroef de aansluitingen op de in-/uitlaat los.
- Voer het resterende water in de condensor door middel van een luchtpistool af.
- Sluit de watertoevoer en -afvoer van de warmtepomp af om te vermijden dat vreemde voorwerpen binnendringen.
- Bedek de warmtepomp met de meegeleverde overwinteringshoes.



***Eender welke schade veroorzaakt door een slechte overwintering, zorgt ervoor dat de garantie geannuleerd wordt.***

# 6. BIJLAGEN

## 6.1 Elektrische schema's

### HP5091DT3HA / HP5111DT3HA

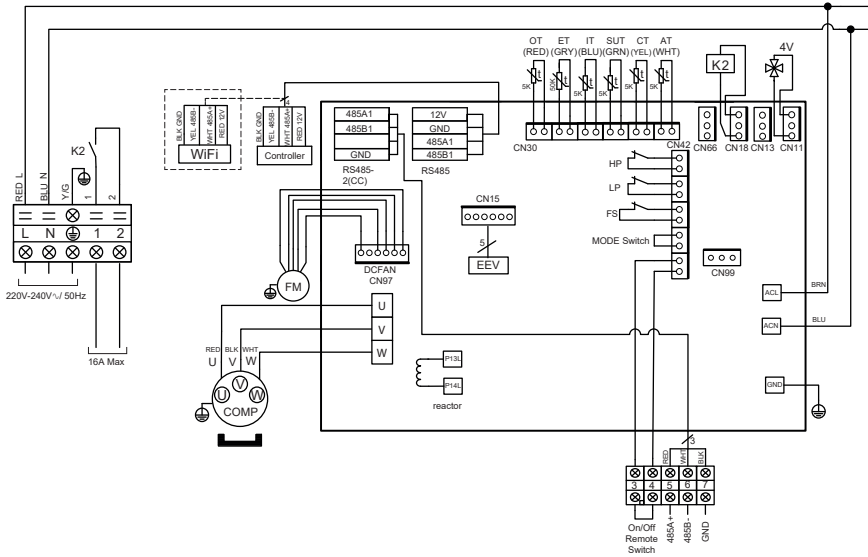

#### OPMERKINGEN

- |   |   |
|---|---|
| <p><b>AT</b> : LUCHTTEMPERATUURSENSOR</p> <p><b>COMP</b> : COMPRESSOR</p> <p><b>CT</b> : CONDENSATIETEMPERatuur SENSOR</p> <p><b>EEV</b> : ELEKTRONISCHE DRUKREGELAAR</p> <p><b>FM</b> : VENTILATORMOTORR</p> <p><b>FS</b> : WATERDETECTOR</p> <p><b>HP</b> : HOGEDRUKSCHAKELAAR</p> <p><b>IT</b> : TEMPERATUURSENSOR VOOR BINNENKOMEND WATER</p> | <p><b>LP</b> : LAGEDRUKSCHAKELAAR</p> <p><b>OT</b> : TEMPERATUURSENSOR VOOR BUITENGAAND WATER</p> <p><b>SUT</b> : AANZUIGTEMPERATUURSENSOR</p> <p><b>4V</b> : 4-WEGSKRAAN</p> <p><b>K2</b> : VOLTURIJ CONTACT MAX 16 A</p> <p><b>ET</b> : TEMPERATUURSENSOR OPSTUWING</p> <p><b>-----</b> : OPTIONEEL</p> |
|---|---|

## 6. BIJLAGEN (vervolg)

### HP5151DT3HA / HP5181DT3HA

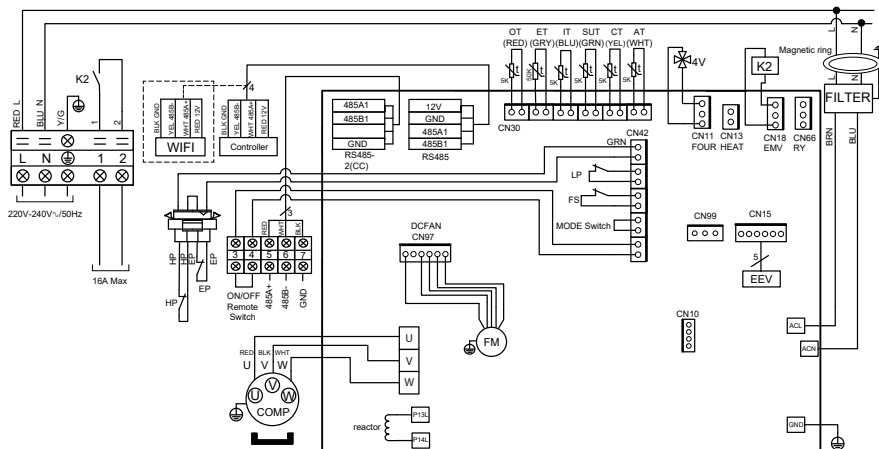

#### OPMERKINGEN

AT : LUCHTTEMPERATUURSSENSOR

COMP : COMPRESSOR

CT : CONDENSATIETEMPERatuur SENSOR

EEV : ELEKTRONISCHE DRUKREGELAAR

FM : VENTILATORMOTORR

FS : WATERDETECTOR

HP : HOGEDRUKSCHAKELAAR

IT : TEMPERATUURSSENSOR VOOR  
BINNENKOMEND WATER

LP : LAGEDRUKSCHAKELAAR

OT : TEMPERATUURSSENSOR VOOR  
BUITENGAAND WATER

SUT : AANZUIGTEMPERATUURSSENSOR

4V : 4-WEGSKRAAN

K2 : VOLTVRIJ CONTACT MAX 16 A

ET : TEMPERATUURSSENSOR OPSTUWING

----- : OPTIONEEL

## 6. BIJLAGEN (vervolg)

### 6.2 Aansluitingen prioriteit verwarming eenfasepomp

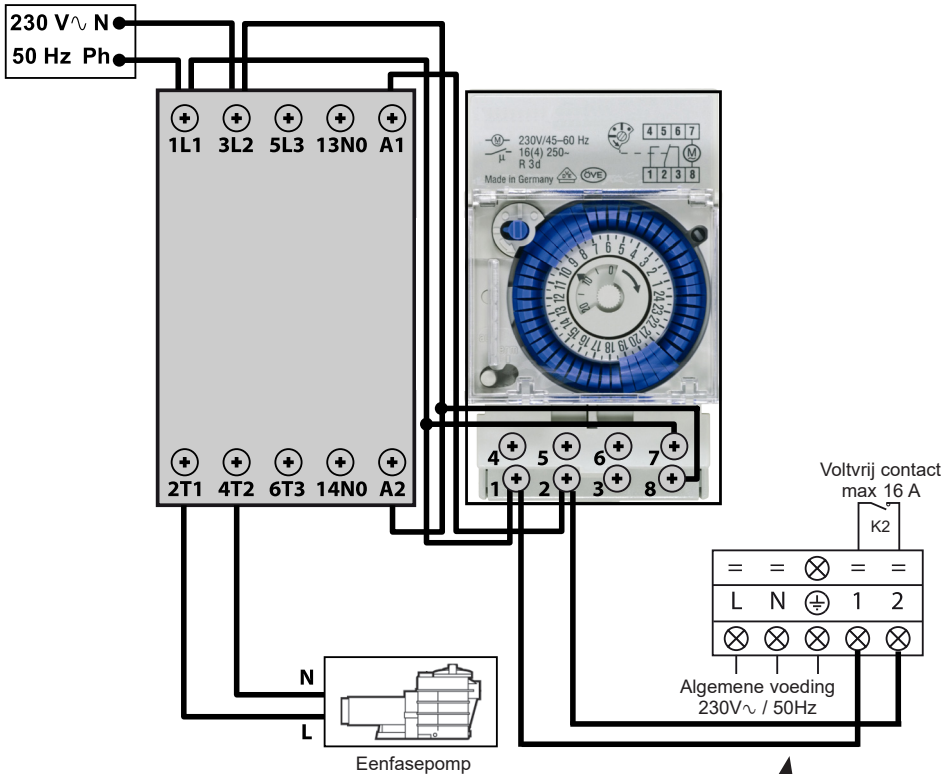

De zuilen 1-2 leveren een spanningvrij contact, zonder polariteit 230 V $\sim$  / 50 Hz.

Sluit de zuilen 1 en 2 met kabels aan zoals op het schema hierboven is aangegeven zodat de werking van de filterpomp wordt ingesteld op een cyclus van 2 minuten per uur als de temperatuur van het bassin lager is dan aanbevolen.

 De voeding van de filterpomp nooit direct aansluiten op de zuilen 1 en 2.





---

*Opzettelijk leeg gelaten pagina*

## 6. BIJLAGEN (vervolg)

### 6.3 Opengewerkte tekeningen en onderdelen

HP5091DT3HA / HP5111DT3HA / HP5151DT3HA / HP5181DT3HA

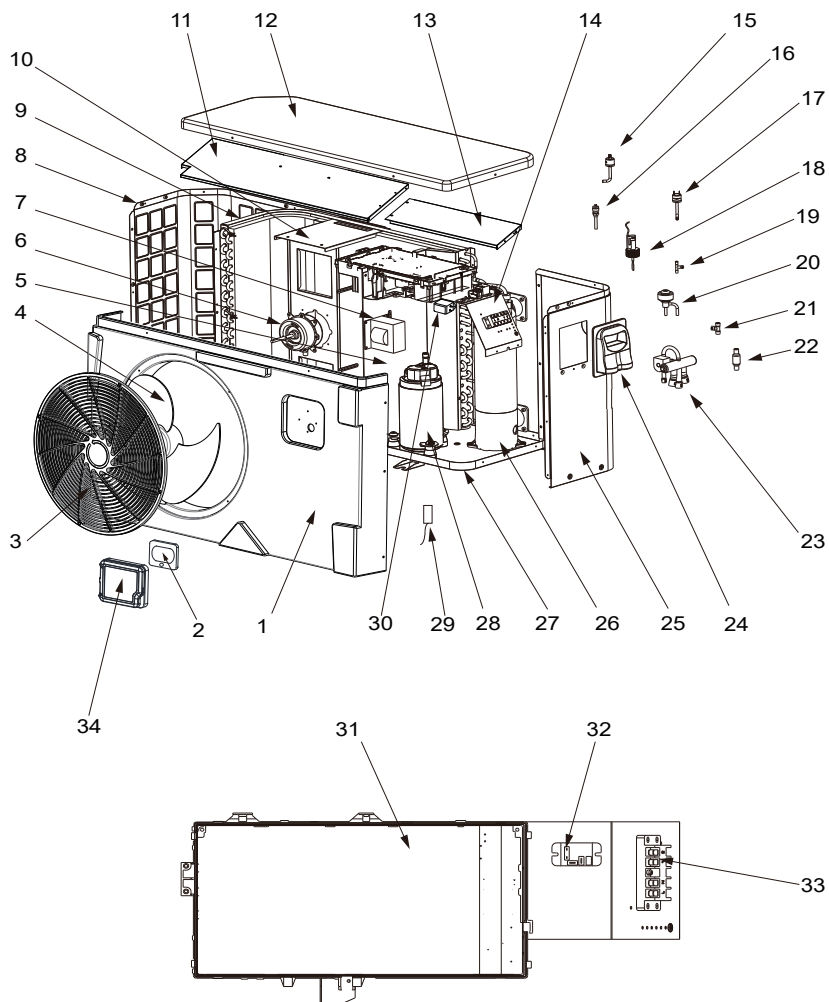

## 6. BIJLAGEN (vervolg)

Nr.	Omschrijving	Réf.	HP5091DT3HA	HP5111DT3HA	HP5151DT3HA	HP5181DT3HA
1	Paneel Voor	HWX80900843	✓	✓	n.v.t	n.v.t
		HWX80900844	n.v.t	n.v.t	✓	n.v.t
		HWX80900850	n.v.t	n.v.t	n.v.t	✓
2	LED Controller	HWX72200070	✓	✓	✓	✓
3	Beschermingsrooster ventilator	HWX80900375	✓	✓	✓	n.v.t
		HWX20000220369	n.v.t	n.v.t	n.v.t	✓
4	Ventilatorblad	HWX301030000006	✓	✓	n.v.t	n.v.t
		HWX301030000001	n.v.t	n.v.t	✓	✓
5	/	/	/	/	/	/
6	Motor ventilator DC	HWX80200018	✓	✓	n.v.t	n.v.t
		HWX20000330132	n.v.t	n.v.t	✓	✓
7	Spoel 16 A 50 Hz 5 mH	HWX82500020	✓	✓	n.v.t	n.v.t
	Spoel 20 A 50 Hz 5.2 mH	HWX82500021	n.v.t	n.v.t	✓	✓
8	Linkerpaneel	HWX80702123	✓	✓	n.v.t	n.v.t
		HWX80700244	n.v.t	n.v.t	✓	n.v.t
		HWX80702268	n.v.t	n.v.t	n.v.t	✓
9	Verdamper met lamellen	HWX80600042	✓	n.v.t	n.v.t	n.v.t
		HWX80600043	n.v.t	✓	n.v.t	n.v.t
		HWX80600044	n.v.t	n.v.t	✓	n.v.t
		HWX80600078	n.v.t	n.v.t	n.v.t	✓
10	Motorsteun	HWX80700218	✓	✓	n.v.t	n.v.t
		HWX80700248	n.v.t	n.v.t	✓	n.v.t
		HWX80700329	n.v.t	n.v.t	n.v.t	✓
11	/	/	/	/	/	/
12	Paneel voorkant boven	HWX80900055	✓	✓	n.v.t	n.v.t
		HWX301090200806	n.v.t	n.v.t	✓	n.v.t
		HWX80900076	n.v.t	n.v.t	n.v.t	✓
13	/	/	/	/	/	/
14	/	/	/	/	/	/
15	Drukregelaar lage druk NO 0.30 MPa / 0.15 MPa	HWX20000360157	✓	✓	✓	✓
16	Drukafsluiter 40 mm-1/2"	HWX20000140150	✓	✓	✓	✓
17	Drukregelaar hoge druk NC 3.2 MPa/4.4 MPa	HWX20013605	✓	✓	✓	✓
18	Detector waterdebiet	HWX83000068	✓	✓	✓	✓
19	T-schakelaar Ø 6.5-2 x Ø 6.5(T) x 0.75	HWX20001460	✓	✓	✓	✓
20	Elektronisch reduceerventiel	HWX81000011	✓	✓	n.v.t	n.v.t
		HWX81000013	n.v.t	n.v.t	✓	✓
21	T-schakelaar Ø 9.52-2 x Ø 6.35(T) x 1.0	HWX304030000002	✓	✓	✓	✓
22	Filter Ø 9.7-Ø 9.7 (Ø19)	HWX20000140178	✓	✓	n.v.t	n.v.t
	Filter Ø 9.7-Ø 9.7 (Ø28)	HWX20041444	n.v.t	n.v.t	✓	✓
23	4-wegskraan	HWX20041437	✓	✓	✓	✓
24	Elektrische toegangsopening	HWX320922029	✓	✓	✓	✓
		HWX80700580	✓	✓	n.v.t	n.v.t
25	Rechterpaneel	HWX80700878	n.v.t	n.v.t	✓	n.v.t
		HWX80700581	n.v.t	n.v.t	n.v.t	✓
		HWX72300013	✓	n.v.t	n.v.t	n.v.t
26	Titaancondensator/pvc	HWX72300014	n.v.t	✓	n.v.t	n.v.t
		HWX72300010	n.v.t	n.v.t	✓	n.v.t
		HWX72300024	n.v.t	n.v.t	n.v.t	✓
		HWX72300010	n.v.t	n.v.t	✓	n.v.t
27	/	/	/	/	/	/
28	Compressor	HWX80100108	✓	✓	n.v.t	n.v.t
		HWX80100046	n.v.t	n.v.t	✓	✓

## 6. BIJLAGEN (vervolg)

HP5091DT3HA / HP5111DT3HA / HP5151DT3HA / HP5181DT3HA

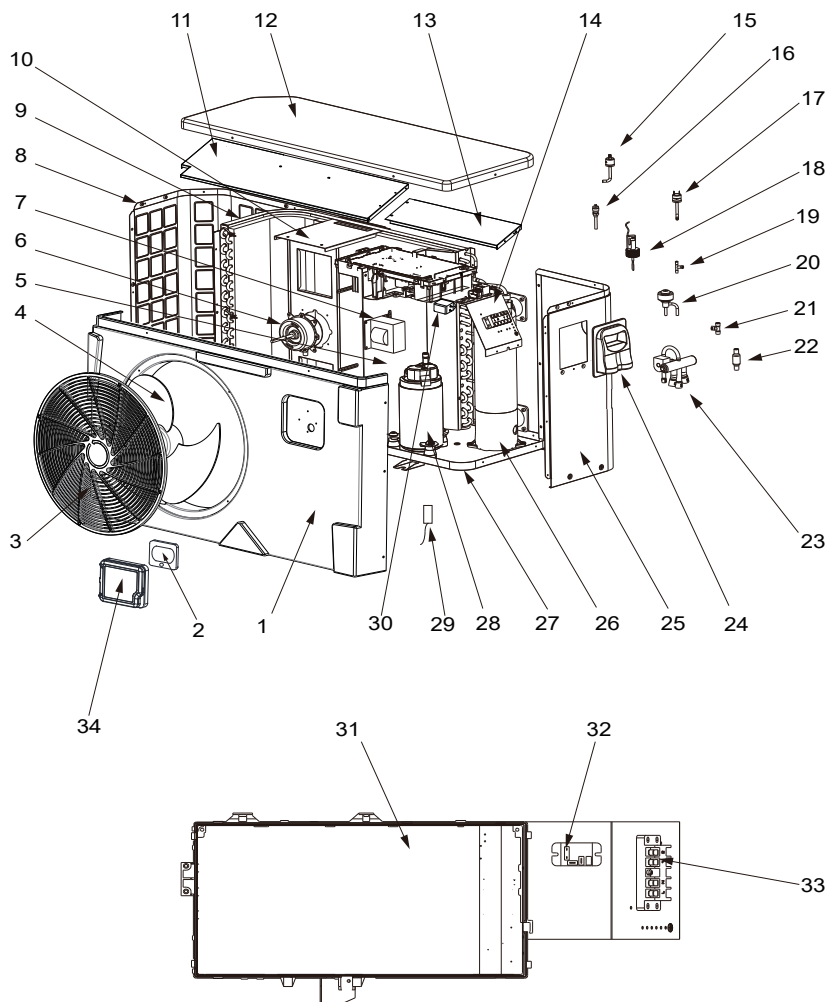

## 6. BIJLAGEN (vervolg)

Nr.	Omschrijving	Réf.	HP5091DT3HA	HP5111DT3HA	HP5151DT3HA	HP5181DT3HA
29	Aspiratiesonde compressor 5 k - 560 mm	HWX83000044	✓	✓	n.v.t	n.v.t
	Aspiratiesonde compressor 5 k - 760 mm	HWX83000053	n.v.t	n.v.t	✓	✓
	Luchttemperatuursonde 5 k - 350 mm	HWX83000049	✓	✓	✓	✓
	Waterafvoer sonde 5 k - 410 mm	HWX83000050	✓	✓	✓	✓
	Sensor voor binnenkomend water 5 k - 850 mm	HWX83000052	✓	✓	✓	n.v.t
	Sensor voor binnenkomend water 5 k - 980 mm	HWX83000055	n.v.t	n.v.t	n.v.t	✓
	Compressor ontlading sonde 50 k - 660 mm	HWX83000026	✓	✓	✓	✓
	Ontdoosensor 5 k - 680 mm	HWX83000051	✓	✓	n.v.t	n.v.t
	Ontdoosensor 5 k - 1040 mm	HWX83000045	✓	✓	✓	✓
30	EMC Filter	HWX20003257	n.v.t	n.v.t	✓	✓
31	Elektronische driver-kaart	HWX72200168AP3	✓	n.v.t	n.v.t	n.v.t
		HWX72200168AP4	n.v.t	✓	n.v.t	n.v.t
		HWX72200167AP5	n.v.t	n.v.t	✓	n.v.t
		HWX72200167AP6	n.v.t	n.v.t	n.v.t	✓
32	Relais K2	HWX20000360297	✓	✓	✓	✓
33	Aansluitblok L-N-GND 5 aansluitingen 4 mm <sup>2</sup>	HWX40003901	✓	✓	✓	✓
34	Beschermingsdeur	HWX80900321	✓	✓	✓	✓

## 6. BIJLAGEN (vervolg)

### 6.4 Gids voor het probleemoplossing





**Sommige handelingen mogen enkel door een bevoegd techniker uitgevoerd worden.**

In geval van een storing aan de warmtepomp verschijnt het  -symbool in de linkerbovenhoek van het display.

In geval van een defect, worden de volgende indicaties op het scherm weergegeven:



**Na het oplossen van het probleem wordt de fout automatisch bevestigd, de driehoek verdwijnt.**

- Om de foutenlijst te wissen, op  .
- Druk 2 maal op  op om terug te keren naar het hoofdscherm.

## 6. BIJLAGEN (vervolg)

Probleem	Foutcodes	Omschrijving	Oplossing
Inlaat watertemperatuur sensor fout	<b>P01</b>	De sensor is open of in kortsluiting	Controleer de CN21/RES1-connector op de printplaat en verleng of vervang de sensor.
Uitlaat watertemperatuur sensor fout	<b>P02</b>		Controleer de N22/RES2-connector op de printplaat en verleng of vervang de sensor.
Omgevingstemperatuursensor fout	<b>P04</b>		Controleer de CN12/PH-connector op de printplaat en verleng of vervang de sensor.
Ontdooisensor fout	<b>P05</b>		Controleer de CN8/OPT-connector op de printplaat en verleng of vervang de sensor.
Defect aspiratiesonde compressor	<b>P07</b>		Controleer de CN7/OAT-connector op de printplaat en verleng of vervang de sensor.
Defect aanzuigsonde Compressor	<b>P081</b>		Controleer de CN9/OHT-connector op de printplaat en verleng of vervang de sensor.
Overdrukbescherming	<b>E01</b>	De sensor is open of in kortsluiting	<p>Controleer de CN30 / HP-connector op het bord of vervang de sensor</p> <p>Waterdebiet controleren</p> <p>Waterdebietdetector controleren</p> <p>Opening van de kleppen controleren</p> <p>Bypass controleren</p> <p>De verdamper op vervuiling controleren</p> <p>Te hoge watertemperatuur</p> <p>Probleem met niet-condenseerbare stoffen, verwijder vloeistof en lucht uit het koelcircuit</p> <p>Te veel vloeistof aanwezig, verwijder de vloeistof in een fles</p>
Onderdrukbescherming	<b>E02</b>	De sensor is open of in kortsluiting	<p>De AI/DI03 aansluiting op de kaart controleren of de sensor vervangen</p> <p>Controleer de lagedrukregelaar en de druk van het koelcircuit om na te gaan of er een lek is.</p> <p>Te laag luchtdebiet, de rotatiesnelheid van de ventilator controleren</p> <p>De verdamper op vervuiling controleren</p>
Debietmeter fout	<b>E03</b>	De sensor is open of in kortsluiting	<p>De AI/DI02 aansluiting op de kaart controleren of de sensor vervangen</p> <p>Te weinig water, de werking van de filterpomp controleren</p> <p>Opening van de stopkleppen controleren</p> <p>Bypass controleren</p>

## 6. BIJLAGEN (vervolg)

Probleem	Foutcodes	Omschrijving	Oplossing
Temperatuurverschil tussen Aanvoer/ Afvoer > 13°C	E06	Alleen in Koude modus toepasbaar	Te weinig water, de werking van de filterpomp controleren
			Opening van de stopkleppen controleren
			Bypass controleren
Antivriesbescherming Koude Modus	E07	Temperatuur waterafvoer < 4°C	De warmtepomp stoppen, de condensor leegmaken, risico op bevriezing
Debietmeter fout	E08	Geen communicatie tussen de elektronische kaart en de gebruikersinterface	Aansluitingen en connectoren controleren - zie elektrisch schema
Antivriesbescherming van niveau 1	E19	< 2°C Watertemperatuur < 4° en luchttemperatuur < 0°	Schakel de warmtepomp uit, maak de condensor leeg om bevriezing te voorkomen, de pomp start standaard de filterpomp om bevriezing te voorkomen
Antivriesbescherming van niveau 2	E29	Watertemperatuur < 2° en luchttemperatuur < 0°	Schakel de warmtepomp uit, maak de condensor leeg om bevriezing te voorkomen, de pomp start standaard de filterpomp en de warmtepomp om bevriezing te voorkomen.
Fout in de ventilatormotor	F031	Motor geblokkeerd of verbinding mislukt	Controleer de vrije rotatie; controleer het CN97/DCFan-aansluitsysteem; vervang de motor.
Fout in de ventilatormotor	F051	Verbindingsfout	DCFAN/CN97-aansluiting controleren; motor vervangen
Buitentemperatuur te laag	TP	Bedrijfslimiet bereikt	Warmtepomp uitschakelen



## 6. BIJLAGEN (vervolg)

---

### 6.5 Garantie

#### GARANTIEVOORWAARDEN

Alle HAYWARD-producten vallen onder garantie in geval van fabrieks- of materiaalfouten gedurende twee jaar vanaf de aankoopdatum. Elke garantieaanvraag moet samen met een aankoopbewijs met datum ingediend worden. Wij dringen er dus op aan dat u uw factuur bewaart.

De HAYWARD-garantie is beperkt tot reparatie of vervanging, bepaald door HAYWARD, van de defecte toestellen zolang ze op een normale wijze en volgens de voorschriften die in de handleiding vermeld, gebruikt zijn, het apparaat niet aangepast is en enkel gebruikt is in met HAYWARD componenten en onderdelen. Schade veroorzaakt door vrieskou en chemische agensen vallen niet onder garantie. Alle andere kosten (transport, werkuren...) worden niet door de garantie gedekt.

HAYWARD kan niet verantwoordelijk gesteld worden voor eender welke directe of indirecte schade veroorzaakt tijdens de installatie, aansluiting of onjuist gebruik van een product.

Om een garantie aan te vragen en herstel of vervanging van een product te eisen, moet u zich tot uw verdeler wenden. Wij zullen geen enkele retour naar de fabriek aanvaarden zonder een vooraf bekomen schriftelijke goedkeuring. Slijtage valt niet onder garantie.

### 6.6 Einde levensduur van het toestel



Het symbool van de doorgekruiste vuilnisbak voor de verwerking en nuttige toepassing van elektrisch en elektronisch afval betekent dat de producten niet bij het huisvuil, het grofvuil of op een stortplaats mogen worden gedeponeerd.

 Aan het einde van zijn levensduur moet het toestel apart worden ingezameld voor recycling of hergebruik. In de Europese Unie en Noorwegen bestaat een specifiek inzamelingsstelsel voor dit soort producten.

Neem contact op met uw installateur of plaatselijke vertegenwoordiger om de inzameling, ontmanteling en recycling van dit toestel te regelen.

Het hergebruik van koelmiddel, olie en andere onderdelen moet worden uitgevoerd door een gekwalificeerde vakman in overeenstemming met de lokale en nationale wetgeving.

Als het product batterijen bevat die met dit symbool zijn gemarkeerd, betekent dit dat de batterijen schadelijke of verontreinigende stoffen kunnen bevatten. Geef de batterijen in dat geval af bij een inzamelpunt voor gebruikte batterijen.

---

*Opzettelijk leeg gelaten pagina*



# **HAYWARD<sup>®</sup>**

## ***FULL INVERTER***

**UNITÀ DI RISCALDAMENTO A POMPA DI CALORE PER PISCINE**



HP5091DT3HA	HP5111DT3HA	HP5151DT3HA	HP5181DT3HA
-------------	-------------	-------------	-------------

**Manuale d'Uso e di Installazione**

# INDICE

<b>1. ISTRUZIONI GENERALI - SICUREZZA</b>	<b>1</b>
<b>2. SPECIFICHE TECNICHE</b>	<b>5</b>
2.1 Dati tecnici della pompa a calore	5
2.2 Soglie di funzionamento	6
2.3 Dimensioni	7
<b>3. INSTALLAZIONE E COLLEGAMENTO</b>	<b>8</b>
3.1 Schema di principio	8
3.2 Pompa di calore	8
3.3 Collegamento idraulico	10
3.4 Collegamento Elettrico	11
3.5 Primo avviamento	12
3.6 Regolazione della portata d'acqua	14
<b>4. INTERFACCIA UTENTE</b>	<b>15</b>
4.1 Presentazione generale	15
4.2 Impostazione di Data e Ora	17
4.3 Regolazione dei Timer ON/OFF	18
4.4 Regolazione del valore prefissato	20
4.5 Blocco e sblocco del touch screen	21
4.6 Configurazione della funzione SILENCE	22
<b>5. MANUTENZIONE E SVERNAMENTO</b>	<b>25</b>
5.1 Manutenzione	25
5.2 Svernamento	25
<b>6. APPENDICI</b>	<b>26</b>
6.1 Schemi Elettrici	26
6.2 Collegamenti priorità riscaldamento pompa monofase	28
6.3 Esplosi e parti di ricambio	30
6.4 Guida alla Risoluzione dei Problemi	34
6.5 Garanzia	37
6.6 Fine vita dell'apparecchio	37

Leggere attentamente e riporre in luogo facilmente accessibile per la consultazione.

La presente documentazione deve essere consegnata al proprietario della piscina, il quale dovrà conservarla in un luogo sicuro.

# 1. ISTRUZIONI GENERALI - SICUREZZA

---

Vi ringraziamo per aver acquistato la nostra pompa a calore per piscina Hayward. La pompa a calore Hayward FULL INVERTER è stata appositamente studiata secondo severe norme di fabbricazione, allo scopo di fornire il più elevato livello di qualità possibile.

Le pompe a calore Hayward vi offriranno eccezionali prestazioni durante tutta la stagione dei bagni adattando la potenza, i consumi elettrici ed il livello acustico alle esigenze di riscaldamento della vostra piscina, grazie al circuito logico di controllo FULL INVERTER.



***Leggere attentamente le istruzioni contenute in questo manuale prima dell'uso***

Il presente manuale contiene tutte le informazioni necessarie riguardo all'installazione, alla risoluzione delle anomalie e alla manutenzione della pompa.

Leggere attentamente il manuale prima di aprire la pompa o di effettuare operazioni di manutenzione sulla stessa. Il costruttore della pompa non sarà ritenuto in alcun caso responsabile di eventuali danni fisici subiti da un utente o di eventuali danni subiti dal materiale in seguito ad errori d'installazione, a tentativi di risoluzione di anomalie o ad interventi di manutenzione inutili. Vanno sempre rispettate le istruzioni contenute nel manuale

Dopo aver letto il presente manuale, riporlo in luogo facilmente accessibile per la consultazione.

## **Personale abilitato**

- L'installazione, i collegamenti elettrici, la manutenzione e le riparazioni dell'apparecchio devono essere effettuati da un professionista autorizzato conformemente allo stato dell'arte e ai testi regolamentari vigenti nel paese in cui l'apparecchio è installato (v. § 3.4). In caso di intervento sul circuito frigorifero, il professionista deve essere in possesso di un'attestazione di capacità alla manipolazione di fluidi frigorigeni.  
Per la Francia:
  - Impianto elettrico in bassa tensione in base alla norma NF-C 15-100.
  - Legislazione sulla manipolazione dei fluidi frigorigeni: decreto 2007/737 e relative ordinanze applicative.

# 1. ISTRUZIONI GENERALI - SICUREZZA (segue)

## Questo prodotto contiene gas refrigerante R32



*Questo apparecchio contiene R32.*

*Non usare mai un refrigerante diverso dall'R32. La miscela di altri corpi gassosi con l'R32 rischia di provocare pressioni anormalmente elevate che possono causare guasti o rotture dei tubi e danni fisici alle persone.*

*Durante le riparazioni o gli interventi di manutenzione, utilizzare tubi di rame conformi alla norma NF EN 12375-1 e alla direttiva europea sulle attrezzature a pressione 97/23/CE.*

*La pompa a calore è sotto pressione: occorre, pertanto, evitare, in qualunque caso, di forare i tubi o di effettuare giunzioni brasate. Rischio di esplosione.*

*Non esporre l'apparecchio alle fiamme, alle scintille o ad altre sorgenti di combustione. La pompa potrebbe esplodere provocando ferite gravi o addirittura mortali.*

*Per rilevare perdite di fluido frigorifero: non utilizzare lampade aiodi o altri rivelatori usando fiamme libere. Non usare in nessun caso potenziali sorgenti di ignizione.*

Questo prodotto contiene gas fluorurati ad effetto serra disciplinati dal Protocollo di Kyoto. Non sprigionare questo gas nell'atmosfera.

Valore GWP<sup>(1)</sup>: 675, Valore basato sul 4° rapporto dell' GIEC.

Gruppo di sicurezza: A2L.

La quantità di refrigerante basata sulla regolamentazione n. 517/ 2014 (F-Gas) è indicata sulla piastrina segnaletica dell'apparecchiatura.

Eventuali interventi sul circuito frigorifero devono essere effettuati da professionisti autorizzati come indicato sopra.

A seconda della legislazione europea o locale in vigore, è possibile che venga richiesto di effettuare ispezioni periodiche volte ad accertare eventuali perdite di refrigerante. Per maggiori informazioni, contattare il proprio rivenditore.

- **Attenzione:** i fluidi frigoriferi possono essere inodori.
- Non forare né riscaldare la tubazione: rischio di esplosione e ustioni gravi.
- Non utilizzare mezzi di accelerazione del processo di sbrinamento o pulizia diversi da quelli raccomandati dal fabbricante.
- L'apparecchio deve essere stoccato in un locale che non contenga sorgenti di ignizione funzionanti in maniera permanente (quali fiamme libere, apparecchi a gas o radiatori elettrici in funzione).

(1) Potenziale di riscaldamento globale

# 1. ISTRUZIONI GENERALI - SICUREZZA (segue)

## Condizioni di installazione

- Questa pompa di calore è esclusivamente destinata al riscaldamento dell'acqua della piscina. Non utilizzare l'apparecchio per altri fini.
- Non cercare di installare da soli l'apparecchio.
- Se riscontrate un difetto o un'anomalia, non installate la pompa e chiamate immediatamente il rivenditore.
- Quando non viene usata, la pompa a calore va riposta in un locale sufficientemente ventilato, dotato di una superficie al suolo di  $A_{\min}$  (m<sup>2</sup>) calcolata secondo la seguente formula :  $A_{\min} = (M / (2.5 \times 0.22759 \times h_0))^2$   
M corrisponde alla carica di refrigerante in kg contenuta nell'apparecchio, mentre  $h_0$  corrisponde all'altezza di stoccaggio. Se la pompa viene riposta a livello del suolo  $h_0 = 0,6$  m.
- Questo prodotto è stato esclusivamente progettato per un utilizzo domestico e un'installazione esterna. L'aria che fuoriesce dal prodotto deve poter scorrere liberamente e non deve essere utilizzata per altri fini, come il riscaldamento o il raffreddamento di locali o edifici.
- Verificare il cavo dell'alimentazione. Se il cavo dell'alimentazione risulta danneggiato, questo dovrà essere sostituito dal fabbricante, da un addetto dell'assistenza post-vendita del produttore o da una persona qualificata e abilitata.
- Il collegamento dell'apparecchio alla terra e la sua continuità sono obbligatori. Il filo di terra deve essere più lungo degli altri fili onde evitare rischi di scosse elettriche in caso di strappamento del cavo. L'impianto elettrico deve obbligatoriamente essere provvisto di una protezione differenziale da 30 mA (cf § 3.4).
- Verificare che le dimensioni del supporto previsto per l'impianto siano adeguate rispetto al peso dell'apparecchiatura.
- **Il mancato rispetto delle presenti indicazioni annulla la garanzia.**

## Istruzioni per la manutenzione

Per garantire la longevità e il corretto funzionamento dell'Unità di Riscaldamento a Pompa di Calore per Piscine, le presenti operazioni di manutenzione devono essere effettuate 1 volta all'anno.

- Le operazioni di manutenzione devono essere eseguite rispettando la frequenza e le modalità indicate nel presente manuale.
- Utilizzare esclusivamente parti di ricambio originali.
- Controllare il cavo di alimentazione. Se il cavo di alimentazione è danneggiato, deve essere sostituito dal produttore, dal suo servizio post-vendita o da una persona qualificata e abilitata.
- Verificare il collegamento dell'apparecchio alla terra e la sua continuità.

# 1. ISTRUZIONI GENERALI - SICUREZZA (segue)

- Pulire l'evaporatore con una spazzola morbida, un getto di aria compressa o con acqua. **Attenzione: non utilizzare in nessun caso idropulitrici.**
- Controllare che lo scarico della condensa avvenga correttamente.
- Controllare che i collegamenti idraulici e quelli elettrici siano serrati correttamente.
- Controllare la tenuta idraulica del condensatore.
- Far controllare la tenuta del circuito frigorifero al rilevatore di perdite da un **professionista autorizzato.**



***Prima di eseguire qualsiasi operazione di manutenzione, assicurarsi che l'unità sia scollegata da ogni fonte di corrente elettrica. Le operazioni di manutenzione devono essere effettuate esclusivamente da personale qualificato e abilitato alla manipolazione di fluidi frigoriferi.***

## Istruzioni per lo svernamento

- Mettere l'unità in Modalità "OFF".
- Interrompere l'alimentazione dell'unità.
- Svuotare il condensatore tramite l'apposito scolo per evitare eventuali rischi di degrado. (elevato rischio di congelamento).
- Chiudere la valvola by-pass e svitare i raccordi di unione ingresso/uscita.
- Eliminare dal condensatore l'acqua stagnante residua servendosi di una pistola ad aria compressa.
- Ostruire l'ingresso e l'uscita dell'acqua dell'unità, al fine di evitare l'eventuale intrusione di corpi estranei.
- Coprire l'unità con l'apposito telo per l'inverno.



***Eventuali danni causati da uno svernamento improprio invalideranno la garanzia.***

## Condizioni di utilizzo

Questo apparecchio può essere utilizzato da bambini che abbiano almeno 8 anni e da persone con capacità fisiche, sensoriali o mentali ridotte, o anche prive di esperienza o conoscenza, fermo restando che siano correttamente sorvegliate, siano state loro fornite istruzioni per un utilizzo dell'apparecchio in totale sicurezza e i rischi potenziali siano stati compresi.

I bambini non devono giocare con l'apparecchio.

La pulizia e la manutenzione da parte dell'utente non devono essere effettuate da bambini senza sorveglianza.



## 2. SPECIFICHE TECNICHE

### 2.1 Dati tecnici della pompa a calore

Modelli	FULL INVERTER	HP5091DT3HA	HP5111DT3HA	HP5151DT3HA	HP5181DT3HA
Tensione di alimentazione	V	220V-240V ~ / 1fase/ 50Hz			
Refrigerante	/	R32			
Carica	kg	0,430	0,450	0,60	0,670
Massa in tCO <sub>2</sub> e	/	0,29	0,30	0,41	0,45
Frequenza di controllo delle perdite	/	Non obbligatoria, ma consigliata una volta all'anno			
Capacità di riscaldamento Min--Max <sup>(a)</sup>	kW	2,46 -- 9,17	2,36 -- 11,45	3,31 -- 15,90	3,2 -- 18,15
Potenza elettrica assorbita Min--Max <sup>(a)</sup>	kW	0,17 -- 1,45	0,17 -- 1,80	0,27 -- 2,84	0,22 -- 3,13
Corrente nominale di esercizio Min--Max <sup>(a)</sup>	A	1,17 -- 6,42	1,19 -- 7,85	1,37 -- 12,35	1,45 -- 13,58
COP Max--Min <sup>(a)</sup>	/	14,37 -- 6,32	13,88 -- 6,35	12,26 -- 5,59	14,34 -- 5,80
Capacità di riscaldamento Min--Max <sup>(b)</sup>	kW	1,75 -- 7,05	1,56 -- 8,00	3,05 -- 12,40	2,86 -- 14,11
Potenza elettrica assorbita Min--Max <sup>(b)</sup>	kW	0,27 -- 1,51	0,279 -- 1,74	0,42 -- 2,65	0,43 -- 2,99
COP Max--Min <sup>(b)</sup>	/	6,40 -- 4,65	5,60 -- 4,80	7,26 -- 4,68	6,63 -- 4,71
Corrente nominale ammissibile (CMS)	A	8,40	9,50	14	15,9
Calibro del fusibile	aM	10	12	16	20
Interruttore curva D	D	10	12	16	20
Corrente di avviamento	A	< CMS			
Allacciamento idraulico	mm	50 mm			
Portata idrica nominale <sup>(a)</sup>	m <sup>3</sup> /h	4,00	5,00	6,70	7,70
Perdita di carica sull'acqua max	kPa	3,80	4,0	6,3	10
Compressore	/	DC Inverter Panasonic		DC Inverter Mitsubishi	
Tipo	/	Double Rotatif		Double Rotatif	
Quantità	/	1			
Resistenza di avvolgimento a 20°C	Ohm	1,208		0,95	
Ventilatore	/	Assiale			
Quantità		1			
Diametro	mm	405		510	
Numero di pale	/	3			
Motore	/	DC Inverter			
Quantità	/	1			
Velocità di rotazione	giri/min.	400 -- 700	500 -- 850	300 -- 750	400 -- 750
Velocità modalità silenziosa	giri/min.	400	500	300	400
Livello di pressione acustica a 1 metro	dB(A)	50,2	53,9	50,8	54,0
Livello di pressione acustica a 10 metri	dB(A)	32,8	34,2	33,8	37,25
Dimensioni nette dell'unità (L-I-H)	mm	1003 / 418 / 605		1048 / 437 / 768 / 1161 / 473 / 862	
Peso	kg	44	45	66	70

(a) Aria asciutta 27°C - Umidità relativa 78% - Temperatura d'ingresso dell'acqua 26°C.



(b) Aria asciutta 15°C - Umidità relativa 71% - Temperatura d'ingresso dell'acqua 26°C.

## 2. SPECIFICHE TECNICHE (segue)

---

### 2.2 Soglie di funzionamento

Per assicurare un funzionamento sicuro ed efficiente, utilizzare la pompa di calore entro le seguenti soglie di temperatura e umidità.

	Modalità riscaldamento 	Modalità Raffreddamento 
Temperatura esterna	-7°C – +35°C	+7°C – +43°C
Temperatura acqua	+12°C – +32°C	+8°C – +40°C
Umidità relativa	< 80%	< 80%
Soglia di configurazione set point	+15°C – +32°C	+8°C – +32°C



***Se la temperatura o l'umidità non soddisfano le suddette condizioni, è possibile che si verifichi l'intervento di dispositivi di sicurezza che impediscano alla pompa di calore di azionarsi.***



***Per evitare eventuali rischi di deterioramento dei liner la temperatura massima di riscaldamento è limitata a 32°C. Hayward declina ogni responsabilità in caso di uso a temperature superiori a +32°C.***

## 2. SPECIFICHE TECNICHE (segue)

### 2.3 Dimensioni

Modelli:

HP5091DT3HA / HP5111DT3HA / HP5151DT3HA / HP5181DT3HA

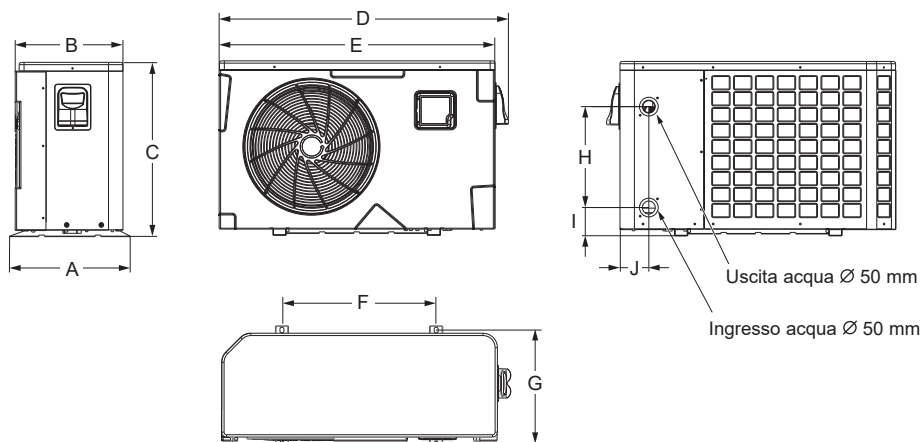

Unità : mm

Modella Numerazione	HP5091DT3HA / HP5111DT3HA	HP5151DT3HA	HP5181DT3HA
<b>A</b>	418	436,5	473
<b>B</b>	374	418	451,5
<b>C</b>	604,5	767,5	862
<b>D</b>	1003	1047,5	1160,5
<b>E</b>	956	1002	1115
<b>F</b>	535	615	790
<b>G</b>	394,5	410	447
<b>H</b>	350	350	466
<b>I</b>	97,7	101,2	97,6
<b>J</b>	99,2	106,5	113,5

## 3. INSTALLAZIONE E COLLEGAMENTO

### 3.1 Schema di principio

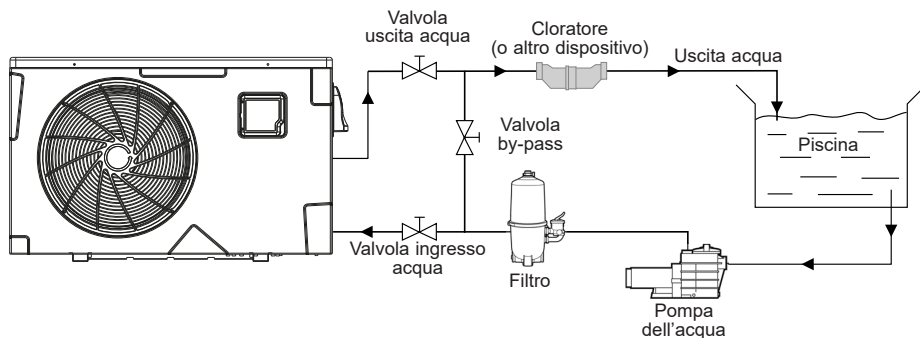

N.B.: L'unità fornita è priva di dispositivi di trattamento o di filtraggio. Gli elementi rappresentati nello schema devono essere forniti dall'installatore.

### 3.2 Pompa di calore



**Installare la pompa di calore all'esterno e al di fuori di locali tecnici chiusi.**

**Scegliere un luogo preferibilmente soleggiato e al riparo da venti dominanti.**

**L'apparecchio deve essere perfettamente accessibile per i lavori di installazione e la successiva manutenzione.**

**Installare l'unità in luogo riparato e rispettare le distanze minime sottoindicate, al fine di evitare il rischio di ricircolo dell'aria o eventuali diminuzioni delle prestazioni complessive dell'unità stessa.**

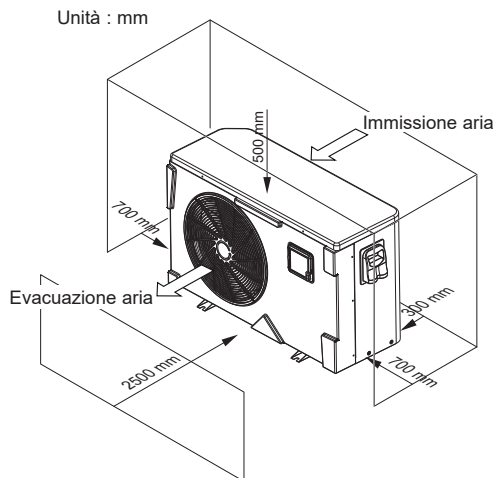

### 3. INSTALLAZIONE E COLLEGAMENTO (segue)



**Non collocare l'apparecchio direttamente a terra perché potrebbe rappresentare un ostacolo.**

**Privilegiare una posizione a terra su piedini antivibrazione.**

**Non usare supporti murali in condizioni suscettibili di trasmettere vibrazioni.**

**Non installare la pompa a calore su un supporto suscettibile di amplificare le vibrazioni prodotte dalla stessa.**

**Non installare la pompa in un luogo suscettibile di amplificarne il livello acustico o in cui il rumore prodotto dall'impianto rischi di disturbare i vicini.**

**Non usare adesivi: non sono considerati mezzi di fissaggio affidabili.**

**Installare preferibilmente la pompa di calore su una soletta di cemento piana e non accoppiata.**

**Montare la pompa di calore sui silent block forniti (viti e rondelle fornite).**

**Fissare l'apparecchio rispettando il serraggio indicato onde evitare rischi di incidente o danneggiamento a cose e persone.**

**Altra possibilità: installare la pompa di calore su supporti a terra in gomma utilizzando viti adatte (non in dotazione).**

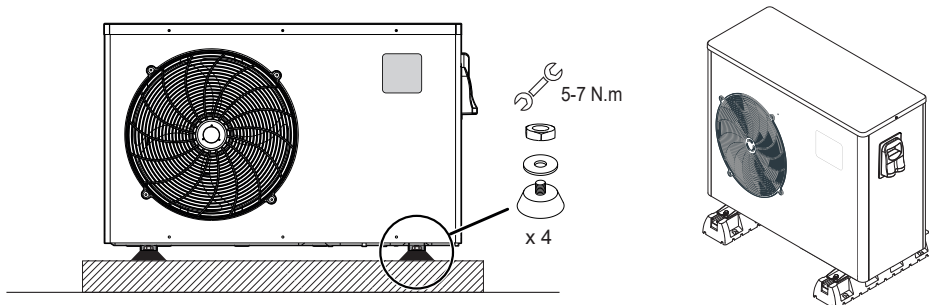

**Distanza max. tra l'unità e la piscina: 15 metri.**

**Lunghezza totale andata/ritorno tubazioni idrauliche: 30 metri.**

**Isolare le tubazioni idrauliche sia interrate che non interrate.**

**La pompa di calore deve essere installata a una distanza minima dalla vasca conforme alla norma NF C 15-100 (ossia, per la Francia, a 3,5 m dallo specchio d'acqua) o conforme alle norme relative all'installazione vigenti negli altri paesi.**

**Non installare la pompa di calore in prossimità di fonti di calore.**

**In caso d'installazione in regioni nevose, si consiglia di proteggere la macchina per prevenire un eventuale accumulo di neve sull'evaporatore.**

## 3. INSTALLAZIONE E COLLEGAMENTO (segue)

---

### 3.3 Collegamento idraulico

L'unità è dotata di due raccordi di unione del diametro di 50 mm. Utilizzare tubi in PVC per tubazioni idrauliche Ø 50 mm. Collegare la tubazione per l'ingresso dell'acqua dell'unità alla conduttura proveniente dal gruppo di filtraggio, quindi collegare la tubazione per lo scarico dell'acqua alla conduttura utilizzata per immettere acqua nella piscina (cf. schema seguente).

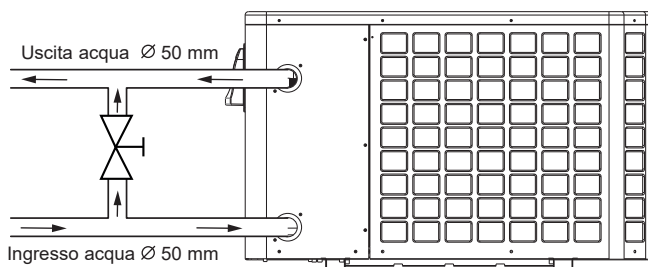

Installare una valvola by-pass tra l'ingresso e l'uscita dell'unità.



***Se si utilizza un cloratore o un cloratore automatico, installare tale dispositivo dopo l'unità, al fine di proteggere il condensatore in Titanio da una concentrazione troppo elevata di prodotto chimico.***



***Per facilitare il drenaggio dell'unità durante la preparazione all'inverno e fornire facile accesso alle operazioni di smontaggio e manutenzione, si consiglia di installare la valvola by-pass e i raccordi di unione in dotazione in corrispondenza dell'ingresso e dell'uscita dell'unità.***

## 3. INSTALLAZIONE E COLLEGAMENTO (segue)

### 3.4 Collegamento Elettrico



**L'installazione elettrica e il cablaggio del presente dispositivo devono essere conformi alle norme d'installazione locali vigenti.**

F	NF C15-100	GB	BS7671:1992
D	DIN VDE 0100-702	EW	EVHS-HD 384-7-702
A	ÖVE 8001-4-702	H	MSZ 2364-702/1994/MSZ 10-553 1/1990
E	UNE 20460-7-702 1993, RECBT ITC-BT-31 2002	M	MSA HD 384-7-702.S2
IRL	Wiring Rules + IS HD 384-7-702	PL	PN-IEC 60364-7-702:1999
I	CEI 64-8/7	CZ	CSN 33 2000 7-702
LUX	384-7.702 S2	SK	STN 33 2000-7-702
NL	NEN 1010-7-702	SLO	SIST HD 384-7-702.S2
P	RSIUEE	TR	TS IEC 60364-7-702



**Assicurarsi che l'alimentazione elettrica disponibile e la frequenza di rete siano adeguate alla corrente operativa richiesta, tenendo in considerazione l'area di collocazione dell'unità e la corrente necessaria ad alimentare ogni altro dispositivo collegato allo stesso circuito.**

**HP5091DT3HA / HP5111DT3HA / HP5151DT3HA / HP5181DT3HA  
230V ~ +/- 10 % 50 Hz 1 Fase**

**Fare riferimento allo schema dell'impianto elettrico corrispondente in appendice.**

**La scatola di collegamento è posta sul lato destro dell'unità. Tre connessioni sono destinate all'alimentazione elettrica e due al comando della pompa di filtraggio (Asservimento).**

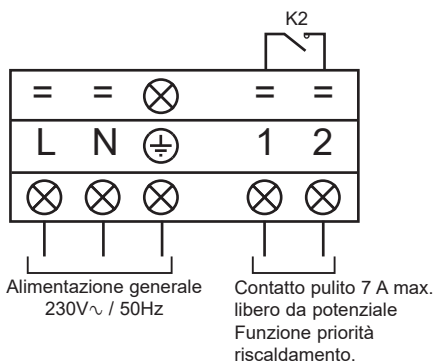

### 3. INSTALLAZIONE E COLLEGAMENTO (segue)

---



**Mai utilizzare prese di corrente per l'alimentazione.**

**La linea di alimentazione elettrica deve essere opportunamente dotata di un dispositivo di protezione onnipolare tipo interruttore curva D e un interruttore differenziale di protezione 30mA (v. tabella seguente).**

Modelli		HP5091DT3HA	HP5111DT3HA	HP5151DT3HA	HP5181DT3HA
Alimentazione elettrica	V/Ph/Hz	230V~ 50Hz	230V~ 50Hz	230V~ 50Hz	230V~ 50Hz
Interruttore curva D	A	8 D	10 D	16 D	20 D
Sezione cavo	mm <sup>2</sup>	3G 2,5	3G 2,5	3G 2,5	3G 4



**Utilizzare un cavo di alimentazione tipo RO2V / 2V o equivalente.**



**Le sezioni del cavo sono fornite per una lunghezza massima di 25 m, ma devono comunque essere controllate e adattate a seconda delle condizioni d'installazione.**



**Staccare sempre l'alimentazione principale prima di aprire la scatola elettrica.**

**Dopo il sezionamento dell'alimentazione, attendere 10 minuti prima di accedere alle parti attive interne dell'apparecchiatura (energia stoccata nei condensatori).**

#### 3.5 Primo avviamento

Procedura di avviamento - dopo aver completato l'installazione, attenersi alla seguente procedura:

- 1) Ruotare manualmente i ventilatori per verificarne la libertà di movimento e per assicurarsi che l'elica sia correttamente fissata all'albero motore.
- 2) Assicurarsi che l'unità sia correttamente collegata alla fonte di alimentazione principale (v. schema dell'impianto elettrico in appendice).
- 3) Attivare la pompa di filtraggio.
- 4) Verificare che tutte le valvole dell'acqua siano aperte e che l'acqua fluisca nell'unità prima di avviare qualsiasi processo di riscaldamento o raffreddamento.
- 5) Verificare che la manichetta per lo scarico della condensa sia correttamente collegata e che non vi sia ostacolo al suo funzionamento.
- 6) Attivare l'alimentazione elettrica destinata all'unità, quindi premere il pulsante ON/OFF  sul pannello di controllo.



### 3. INSTALLAZIONE E COLLEGAMENTO (segue)

---

- 7) Verificare che non vengano visualizzati i simboli indicanti un allarme o un blocco. Qualora venissero visualizzati tali simboli, consultare l'apposito manuale (v. § 6.4).
- 8) Definire la portata dell'acqua agendo sulla valvola by-pass (v. § 3.6 e 2.1) secondo le indicazioni riportate sulla targhetta identificativa del modello, fino a ottenere una differenza nella temperatura dell'acqua in Ingresso/ Uscita di 2°C.
- 9) Dopo alcuni minuti di utilizzo, assicurarsi che l'aria in uscita sia più fredda (5-10°C).
- 10) Ad unità avviata, spegnere la pompa di filtraggio. L'unità si spegne automaticamente e viene visualizzato il codice errore E03.
- 11) Lasciare l'unità e la pompa piscina in funzione per 24 ore al giorno fino a quando l'acqua non raggiunge la temperatura desiderata. Quando la temperatura dell'acqua in ingresso raggiunge il valore predefinito, l'unità si spegne. L'unità si riavvia automaticamente (fino a quando la pompa della piscina rimane in funzione) quando la temperatura dell'acqua scende di 0,5°C rispetto alla temperatura impostata.

**Interruttore di portata** - L'unità è dotata di un interruttore di portata che ne regola l'accensione, quando la pompa di filtraggio della piscina è in funzione, e lo spegnimento, quando la pompa di filtraggio della piscina è fuori servizio. Se il livello dell'acqua è troppo basso, il codice d'allarme E03 viene visualizzato sul regolatore (v. § 6.4).

**Temporizzazione** - L'unità è dotata di un dispositivo di temporizzazione con ritardo di 3 minuti atto a proteggere i componenti del circuito di controllo e a prevenire avvii intempestivi e interferenze concernenti il contattore. Questa funzione riavvia automaticamente l'unità circa 3 minuti dopo ogni interruzione del circuito di controllo. Tale dispositivo si attiva anche in seguito a una breve interruzione di corrente.

### 3. INSTALLAZIONE E COLLEGAMENTO (segue)

---

#### 3.6 Regolazione della portata d'acqua

Tenendo aperte le valvole, regolare la valvola by-pass in modo tale da ottenere una differenza di 2° C tra la temperatura dell'acqua in ingresso e la temperatura dell'acqua in uscita (v. schema di principio § 3.1). È possibile accertarsi della corretta regolazione verificando la temperatura dell'acqua in ingresso e in uscita visualizzata sul pannello di controllo.



N.B.: L'apertura della valvola by-pass genera una portata minore e un conseguente aumento del  $\Delta T$ .  
La chiusura della valvola by-pass genera una portata maggiore e una conseguente diminuzione del  $\Delta T$ .

## 4. INTERFACCIA UTENTE

### 4.1 Presentazione generale

L'unità è dotata di un pannello di comando digitale touch screen collegato elettricamente e preimpostato in fabbrica in modalità riscaldamento.

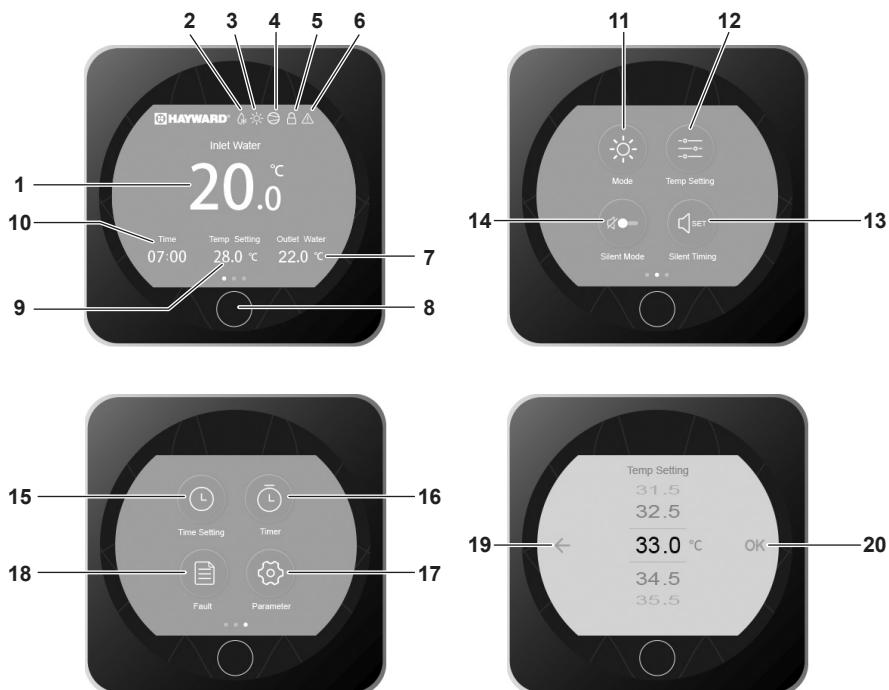

### Legenda

1	Temperatura acqua in Ingresso
2	Modalità sbrinamento
3	Modalità di funzionamento
4	Spia di accensione del compressore
5	Blocco dello schermo
6	Allarme
7	Temperatura di uscita dell'acqua
8	On/Off/Ritorno
9	Temperatura prefissata
10	Ora

11	Selezione della modalità di funzionamento
12	Regolazione del valore prefissato
13	Regolazione timer modalità silenzioso
14	Attivazione della modalità silenziosa
15	Regolazione data e ora
16	Regolazione Timer ON/OFF
17	Accesso parametri avanzati
18	Accesso elenco delle anomalie
19	Ritorno (senza convalida)
20	Convalida

## 4. INTERFACCIA UTENTE (segue)

---

### Modalità OFF

Quando la pompa è ferma (in attesa), la scritta OFF viene visualizzata come indicato sullo schermo. Lo schermo nero indica che la pompa è ferma: i parametri possono essere impostati con questa modalità.



### Modalità ON

Quando la pompa funziona o è in corso di regolazione (raggiungimento del valore prefissato) lo schermo diventa blu.





Per passare da OFF a ON e viceversa premere il pulsante .

## 4. INTERFACCIA UTENTE (segue)

### 4.2 Impostazione di Data e Ora

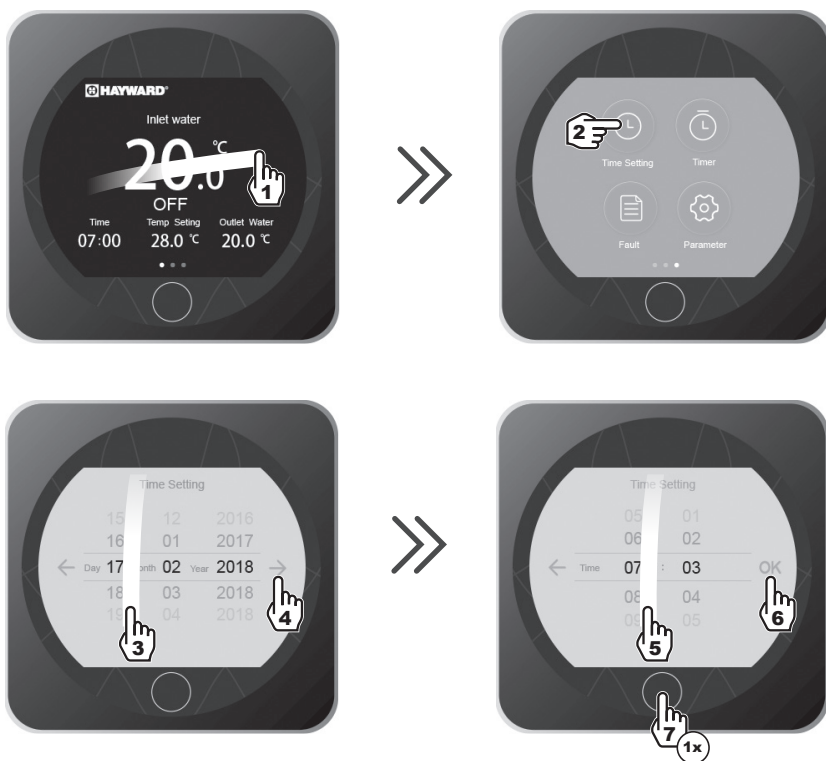
L'impostazione della data e dell'ora può essere effettuata con modalità ON o OFF.



- Premere 1 volte  per tornare alla schermata principale.

## 4. INTERFACCIA UTENTE (segue)

### 4.3 Regolazione dei Timer ON/OFF

La configurazione di questa funzione è necessaria se si desidera azionare l'unità per un periodo più breve rispetto a quello impostato tramite l'orologio che regola l'azionamento della pompa di filtraggio. In questo modo, è possibile ritardare l'avvio, anticipare l'arresto o impedire l'avviamento dell'unità durante una determinata fascia oraria (ad esempio di notte).

È possibile programmare fino a un Timer Partenza e un Timer Stop. I passi di regolazione sono «di ora» in ora».



## 4. INTERFACCIA UTENTE (segue)

---



 **Evidenziato blu = Attivato**  
**Grigio = Disattivato**

- Premere 2 volte  per tornare alla schermata principale.

## 4. INTERFACCIA UTENTE (segue)

### 4.4 Regolazione del valore prefissato

L'impostazione del valore prefissato viene effettuata sia con modalità ON che con modalità OFF, con una tolleranza di 0,5°C.



- Premere 1 volte  per tornare alla schermata principale.



**Si raccomanda di non oltrepassare la temperatura di 30°C al fine di evitare di alterare i liner.**



## 4. INTERFACCIA UTENTE (segue)

### 4.5 Blocco e sblocco del touch screen

Lo schermo può essere bloccato e sbloccato sia con modalità ON che con modalità OFF.



Blocco attivato



Blocco disattivato

## 4. INTERFACCIA UTENTE (segue)

### 4.6 Configurazione della funzione SILENCE

La modalità silenzioso permette di usare la pompa di calore risparmiando energia e generando molto meno rumore quando le esigenze di riscaldamento sono ridotte (mantenimento della vasca a temperatura o necessità di avere un funzionamento ultrasilenzioso).

Questa funzione può essere attivata o disattivata manualmente o tramite un timer.

#### Attivazione/ Disattivazione



Modalità silenziosa disattivata



Modalità Silenzioso attivata



- Premere 1 volte  per tornare alla schermata principale.

## 4. INTERFACCIA UTENTE (segue)

---

### Regolazione della modalità SILENZIOSA su Timer



## 4. INTERFACCIA UTENTE (segue)

---



- Premere 2 volte  per tornare alla schermata principale.



***Il passo di regolazione è «di ora in ora».  
Una volta attivato, il Timer rimane attivo 7 giorni su 7.***

## 5. MANUTENZIONE E SVERNAMENTO

---

### 5.1 Manutenzione

Per garantire la longevità e il corretto funzionamento dell'Unità di Riscaldamento a Pompa di Calore per Piscine, le presenti operazioni di manutenzione devono essere effettuate 1 volta all'anno.

- La manutenzione e le riparazioni dell'apparecchio devono essere effettuati da un professionista autorizzato conformemente allo stato dell'arte e ai testi regolamentari vigenti nel paese in cui l'apparecchio è installato (v. § 3.4). In caso di intervento sul circuito frigorifero, il professionista deve essere in possesso di un'attestazione di capacità alla manipolazione di fluidi frigorigeni.
- Controllare il cavo di alimentazione. Se il cavo di alimentazione è danneggiato, deve essere sostituito dal produttore, dal suo servizio post-vendita o da una persona qualificata e abilitata.
- Verificare il collegamento dell'apparecchio alla terra e la sua continuità.
- Pulire l'evaporatore con una spazzola morbida, un getto di aria compressa o con acqua. **Attenzione: non utilizzare in nessun caso idropulitrici.**
- Controllare che lo scarico della condensa avvenga correttamente.
- Controllare che i collegamenti idraulici e quelli elettrici siano serrati correttamente.
- Controllare la tenuta idraulica del condensatore.
- Far controllare la tenuta del circuito frigorifero al rilevatore di perdite da un **professionista autorizzato**.



***Prima di eseguire qualsiasi operazione di manutenzione, assicurarsi che l'unità sia scollegata da ogni fonte di corrente elettrica. Le operazioni di manutenzione devono essere effettuate esclusivamente da personale qualificato e abilitato alla manipolazione di fluidi frigorigeni.***

### 5.2 Svernamento

- Mettere l'unità in Modalità "OFF".
- Interrompere l'alimentazione dell'unità.
- Svuotare il condensatore tramite l'apposito scolo per evitare eventuali rischi di degrado. (elevato rischio di congelamento).
- Chiudere la valvola by-pass e svitare i raccordi di unione ingresso/uscita.
- Eliminare dal condensatore l'acqua stagnante residua servendosi di una pistola ad aria compressa.
- Ostruire l'ingresso e l'uscita dell'acqua dell'unità, al fine di evitare l'eventuale intrusione di corpi estranei.
- Coprire l'unità con l'apposito telo per l'inverno.



***Eventuali danni causati da uno svernamento improprio invalideranno la garanzia.***



# 6. APPENDICI (segue)

## HP5151DT3HA / HP5181DT3HA

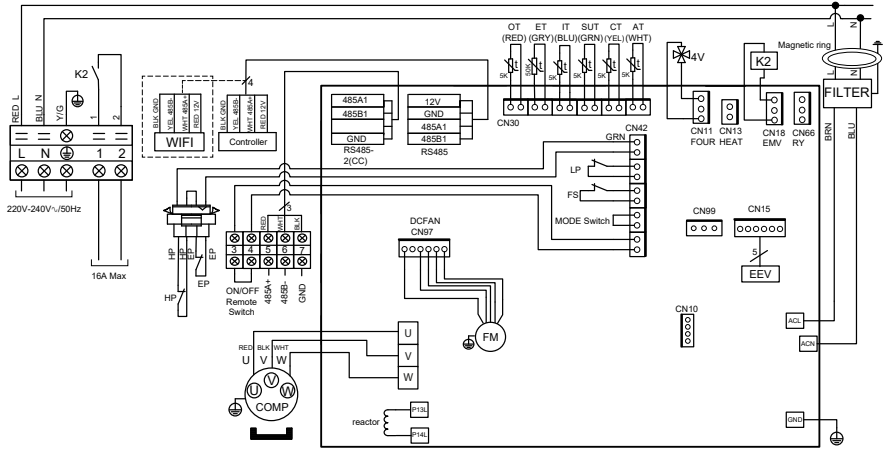

### LEGENDA:

- |  |  |
|--|--|
| <b>AT</b> : SONDA TEMPERATURA ARIA               | <b>LP</b> : PRESSOSTATO BASSA PRESSIONE                    |
| <b>COMP</b> : COMPRESSORE                        | <b>OT</b> : SONDA TEMPERATURA ACQUA IN USCITA              |
| <b>CT</b> : SONDA TEMPERATURA EVAPORATORE        | <b>SUT</b> : SONDA TEMPERATURA ASPIRAZIONE                 |
| <b>EEV</b> : REGOLATORE DI PRESSIONE ELETTRONICO | <b>4V</b> : VALVOLA 4 VIE                                  |
| <b>FM</b> : MOTORE VENTOLA                       | <b>K2</b> : CONTATTO PULITO LIBERO DA POTENZIALE 16 A MAX. |
| <b>FS</b> : RILEVATORE ACQUA                     | <b>ET</b> : SONDA TEMPERATURA DI MANDATA                   |
| <b>HP</b> : PRESSOSTATO ALTA PRESSIONE           | <b>OPTIONAL</b> : OPTIONAL                                 |
| <b>IT</b> : SONDA TEMPERATURA ACQUA IN INGRESSO  |  |

## 6. APPENDICI (segue)

### 6.2 Collegamenti priorità riscaldamento pompa monofase

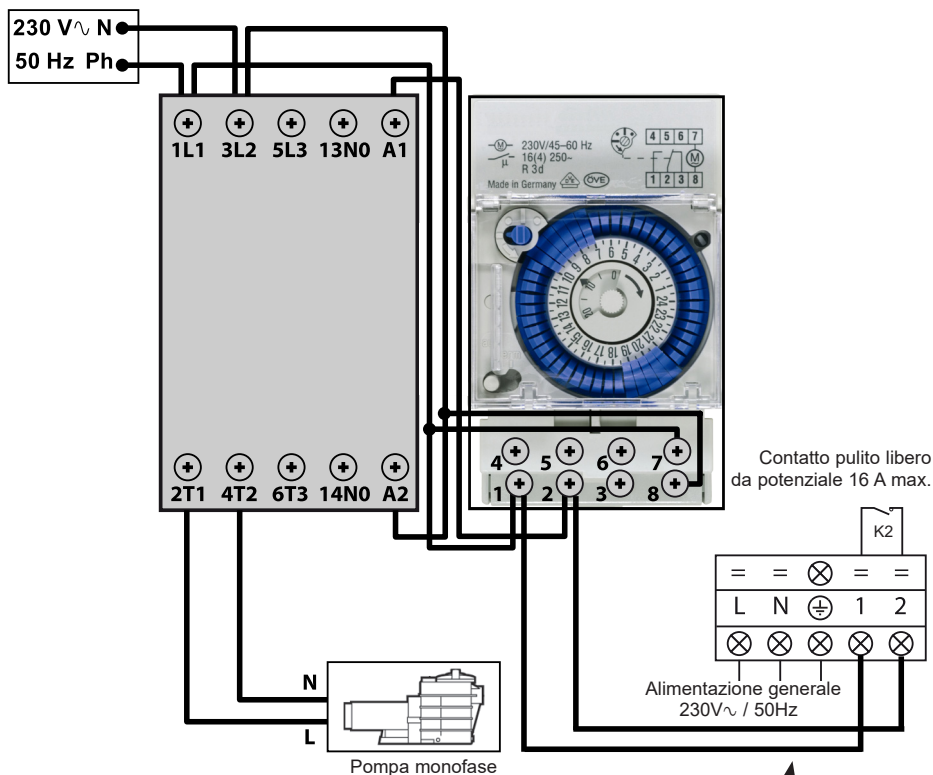

I morsetti 1 e 2 offrono un contatto pulito libero da potenziale, senza polarità 230 V~ / 50 Hz.

Collegare i morsetti 1 e 2 come indicato nello schema di cablaggio di cui sopra per garantire il funzionamento della pompa di filtraggio per un ciclo di 2 min. ogni ora qualora la temperatura all'interno della vasca fosse inferiore al set point impostato.

 Non collegare l'alimentazione della pompa di filtraggio direttamente ai morsetti 1 e 2.





---

*Pagina lasciata intenzionalmente bianca*

## 6. APPENDICI (segue)

### 6.3 Esplosi e parti di ricambio

HP5091DT3HA / HP5111DT3HA / HP5151DT3HA / HP5181DT3HA

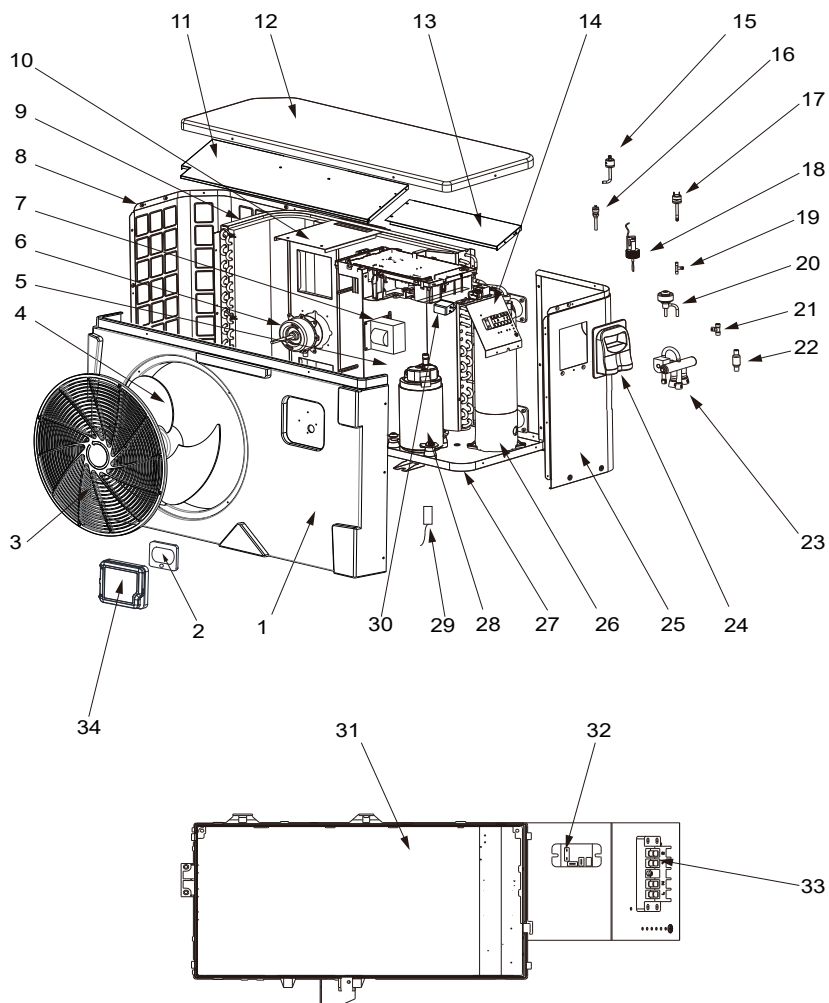

## 6. APPENDICI (segue)

Num.	Designazione	Rif.	HP5091DT3HA	HP5111DT3HA	HP5151DT3HA	HP5181DT3HA
1	Pannello anteriore	HWX80900843	✓	✓	n/a	n/a
		HWX80900844	n/a	n/a	✓	n/a
		HWX80900850	n/a	n/a	n/a	✓
2	Regolatore LED	HWX72200070	✓	✓	✓	✓
3	Griglia di protezione ventilatore	HWX80900375	✓	✓	✓	n/a
		HWX20000220369	n/a	n/a	n/a	✓
4	Elica ventilatore	HWX301030000006	✓	✓	n/a	n/a
		HWX301030000001	n/a	n/a	✓	✓
5	/	/	/	/	/	/
6	Motore ventola DC	HWX80200018	✓	✓	n/a	n/a
		HWX20000330132	n/a	n/a	✓	✓
7	Bobina 16 A 50 Hz 5 mH	HWX82500020	✓	✓	n/a	n/a
	Bobina 20 A 50 Hz 5.2 mH	HWX82500021	n/a	n/a	✓	✓
8	Pannello sinistro	HWX80702123	✓	✓	n/a	n/a
		HWX80700244	n/a	n/a	✓	n/a
		HWX80702268	n/a	n/a	n/a	✓
9	Evaporatore a piastre	HWX80600042	✓	n/a	n/a	n/a
		HWX80600043	n/a	✓	n/a	n/a
		HWX80600044	n/a	n/a	✓	n/a
		HWX80600078	n/a	n/a	n/a	✓
10	Supporto motore	HWX80700218	✓	✓	n/a	n/a
		HWX80700248	n/a	n/a	✓	n/a
		HWX80700329	n/a	n/a	n/a	✓
11	/	/	/	/	/	/
12	Pannello superiore	HWX80900055	✓	✓	n/a	n/a
		HWX301090200806	n/a	n/a	✓	n/a
		HWX80900076	n/a	n/a	n/a	✓
13	/	/	/	/	/	/
14	/	/	/	/	/	/
15	Pressostato Bassa pressione NO 0.30 MPa / 0.15 MPa	HWX20000360157	✓	✓	✓	✓
16	Rilevamento pressione 40 mm-1/2"	HWX20000140150	✓	✓	✓	✓
17	Pressostato Alta pressione NC 3.2 MPa/4.4 MPa	HWX20013605	✓	✓	✓	✓
18	Rilevatore portata acqua	HWX83000068	✓	✓	✓	✓
19	Connettore a T Ø 6.5-2 x Ø 6.5(T) x 0.75	HWX20001460	✓	✓	✓	✓
20	Riduttore di pressione elettronico	HWX81000011	✓	✓	n/a	n/a
		HWX81000013	n/a	n/a	✓	✓
21	Connettore a T Ø 9.52-2 x Ø 6.35(T) x 1.0	HWX304030000002	✓	✓	✓	✓
22	Filtro Ø 9.7-Ø 9.7 (Ø19)	HWX20000140178	✓	✓	n/a	n/a
	Filtro Ø 9.7-Ø 9.7 (Ø28)	HWX20041444	n/a	n/a	✓	✓
23	Valvola 4 vie	HWX20041437	✓	✓	✓	✓
24	Portello d'accesso scatola elettrica	HWX320922029	✓	✓	✓	✓
		HWX80700580	✓	✓	n/a	n/a
25	Pannello destro	HWX80700878	n/a	n/a	✓	n/a
		HWX80700581	n/a	n/a	n/a	✓
		HWX72300013	✓	n/a	n/a	n/a
26	Condensatore Titanio/PVC	HWX72300014	n/a	✓	n/a	n/a
		HWX72300010	n/a	n/a	✓	n/a
		HWX72300024	n/a	n/a	n/a	✓
27	/	/	/	/	/	/
28	Compressore	HWX80100108	✓	✓	n/a	n/a
		HWX80100046	n/a	n/a	✓	✓

## 6. APPENDICI (segue)

HP5091DT3HA / HP5111DT3HA / HP5151DT3HA / HP5181DT3HA

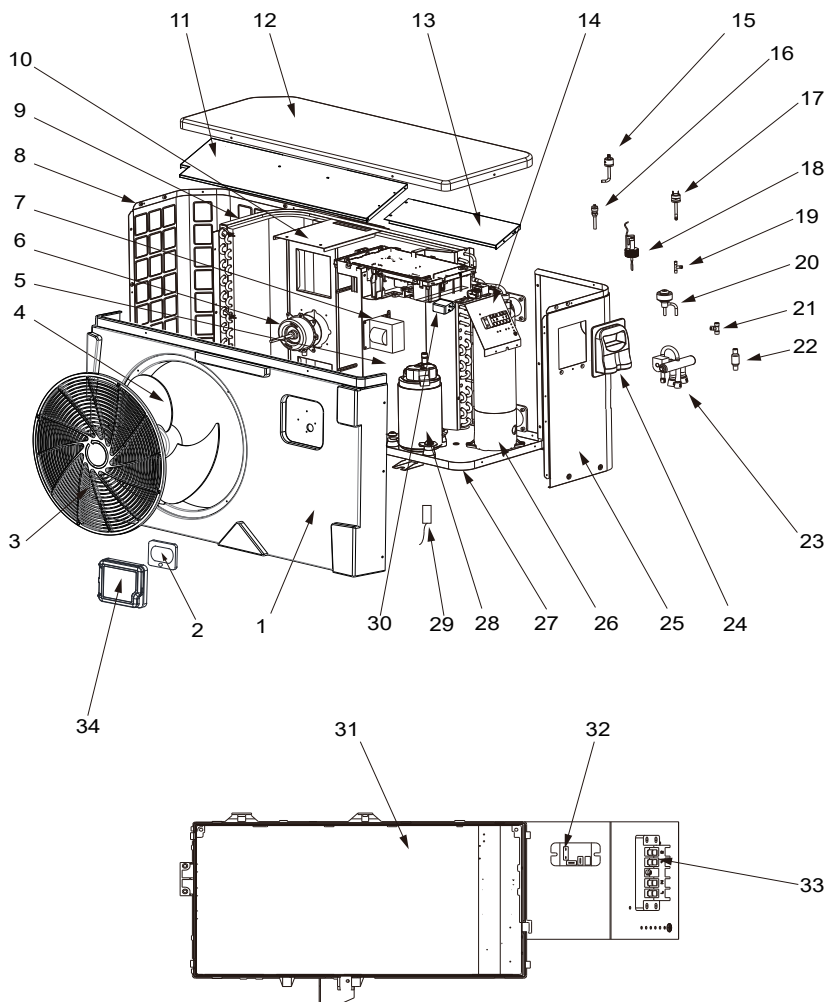

## 6. APPENDICI (segue)

Num.	Designazione	Rif.	HP5091DT3HA	HP5111DT3HA	HP5151DT3HA	HP5181DT3HA
29	Sonda di aspirazione compressore 5 k - 560 mm	HWX83000044	✓	✓	n/a	n/a
	Sonda di aspirazione compressore 5 k - 760 mm	HWX83000053	n/a	n/a	✓	✓
	Sonda temperatura aria Air 5 k - 350 mm	HWX83000049	✓	✓	✓	✓
	Sonda uscita acqua 5 k - 410 mm	HWX83000050	✓	✓	✓	✓
	Sonda temperatura acqua in ingresso 5 k - 850 mm	HWX83000052	✓	✓	✓	n/a
	Sonda temperatura acqua in ingresso 5 k - 980 mm	HWX83000055	n/a	n/a	n/a	✓
	Sonda scarico compressore 50 k - 660 mm	HWX83000026	✓	✓	✓	✓
	Sonda antigelo 5 k - 680 mm	HWX83000051	✓	✓	n/a	n/a
	Sonda antigelo 5 k - 1040 mm	HWX83000045	✓	✓	✓	✓
30	Filtro EMC	HWX20003257	n/a	n/a	✓	✓
31	Scheda elettronica Driver	HWX72200168AP3	✓	n/a	n/a	n/a
		HWX72200168AP4	n/a	✓	n/a	n/a
		HWX72200167AP5	n/a	n/a	✓	n/a
		HWX72200167AP6	n/a	n/a	n/a	✓
32	Relè K2	HWX20000360297	✓	✓	✓	✓
33	Morsettiera L-N-GND 5 connessioni 4 mm <sup>2</sup>	HWX40003901	✓	✓	✓	✓
34	Porta di protezione	HWX80900321	✓	✓	✓	✓

## 6. APPENDICI (segue)

### 6.4 Guida alla Risoluzione dei Problemi





**Alcune delle presenti operazioni devono essere effettuate da un tecnico autorizzato.**

In caso di anomalia sulla pompa a calore, viene visualizzato il simbolo  nell'angolo superiore sinistro dello schermo.

In caso di problemi sullo schermo compaiono le seguenti indicazioni:



**Una volta risolta l'anomalia, l'errore viene automaticamente risolto e il triangolo scompare.**

- Per cancellare l'elenco degli errori, toccare .
- Premere 2 volte  per tornare alla schermata principale.

## 6. APPENDICI (segue)

<b>Malfunzionamento</b>	<b>Codice errore</b>	<b>Descrizione</b>	<b>Soluzione</b>
Guasto sonda temperatura acqua in ingresso	<b>P01</b>	Circuito aperto o cortocircuito	Verificare la connessione CN21/RES1 sulla scheda e il connettore prolunga oppure sostituire il sensore
Guasto sonda acqua in uscita	<b>P02</b>		Verificare la connessione N22/RES2 sulla scheda e il connettore prolunga oppure sostituire il sensore
Guasto sonda temperatura esterna	<b>P04</b>		Verificare la connessione CN12/PH sulla scheda e il connettore prolunga oppure sostituire il sensore
Guasto sonda antigelo	<b>P05</b>		Verificare la connessione CN8/OPT sulla scheda e il connettore prolunga oppure sostituire il sensore
Guasto sonda di aspirazione compressore	<b>P07</b>		Verificare la connessione CN7/OAT sulla scheda e il connettore prolunga oppure sostituire il sensore
Guasto sonda di mandata Compressore	<b>P081</b>		Verificare la connessione CN9/OHT sulla scheda e il connettore prolunga oppure sostituire il sensore
Protezione alta pressione	<b>E01</b>	Circuito aperto o cortocircuito	Verificare la connessione CN30/HP sulla scheda e il connettore prolunga oppure sostituire il sensore
			Controllare la portata d'acqua
			Controllare il sensore della portata d'acqua
			Controllare l'apertura delle valvole
			Controllare la valvola by-pass
			Controllare il livello di sporco dell'evaporatore
			Temperatura acqua troppo calda
			Problema incondensabile in seguito a manutenzione, svuotare e porre sottovuoto il circuito frigorifero
Carico fluido eccessivo, espellere il fluido in una bombola			
Protezione bassa pressione	<b>E02</b>	Circuito aperto o cortocircuito	Controllare i collegamenti AI/DI03 della scheda o sostituire il sensore
			Perdita rilevante di fluido frigorifero, cercare la perdita con il rilevatore
			Portata aria troppo bassa, controllare la velocità di rotazione della ventola
			Controllare il livello di sporco dell'evaporatore e pulirne la superficie
Guasto sensore di portata	<b>E03</b>	Circuito aperto o cortocircuito	Controllare i collegamenti AI/DI02 della scheda o sostituire il sensore
			Manca acqua, controllare che la pompa di filtrazione funzioni correttamente
			Controllare che le valvole di arresto siano aperte
			Controllare la regolazione della valvola by-pass

## 6. APPENDICI (segue)

<b>Malfunzionamento</b>	<b>Codice errore</b>	<b>Descrizione</b>	<b>Soluzione</b>
Differenza di temperatura Ingresso/ Uscita > 13°C	<b>E06</b>	Applicabile solo in modalità Freddo	Manca acqua, controllare che la pompa di filtrazione funzioni correttamente
			Controllare che le valvole di arresto siano aperte
			Controllare la regolazione della valvola by-pass
Protezione antigelo Modalità raffreddamento	<b>E07</b>	Temperatura acqua in uscita < a 4°C	Interrompere il funzionamento della pompa di calore, spurgare il condensatore antigelo
Guasto nel circuito di comunicazione	<b>E08</b>	Assenza di comunicazione tra la scheda elettronica e l'interfaccia utente	Verificare i collegamenti e la connessione – vedi schema elettrico
Protezione antigelo livello 1	<b>E19</b>	2°< Temperatura acqua <4° e Temperatura aria <0°	Interrompere il funzionamento della pompa di calore, spurgare il condensatore antigelo, la pompa di calore avvia automaticamente la pompa di filtrazione per evitare il gelo
Protezione antigelo livello 2	<b>E29</b>	Temperatura acqua < a 2° e Temperatura aria < 0°	Interrompere il funzionamento della pompa di calore, spurgare il condensatore antigelo, la pompa di calore avvia automaticamente la pompa di filtrazione e la pompa di calore per evitare il gelo.
Anomalie motore ventilatore	<b>F031</b>	Motore bloccato o difetto di collegamento	Verificare la corretta rotazione; verificare la connessione CN97/DCFan; sostituire il motore
Anomalie motore ventilatore	<b>F051</b>	Difetto di collegamento	Verificare la connessione DCFAN/ CN97; sostituire il motore
Temperatura esterna troppo bassa	<b>TP</b>	Raggiungimento del limite di funzionamento	Fermare la pompa



## 6. APPENDICI (segue)

---

### 6.5 Garanzia

#### CONDIZIONI DI GARANZIA

Tutti i prodotti HAYWARD sono garantiti contro tutti i difetti di fabbricazione o di materiale per un periodo di due anni dalla data di acquisto. Le eventuali richieste garanzia dovranno essere accompagnate dalla prova di acquisto comprovante detta data. Si raccomanda pertanto di conservare la fattura.

La garanzia HAYWARD è limitata alla riparazione o alla sostituzione, a discrezione della stessa HAYWARD, dei prodotti difettosi solo ed esclusivamente in caso di normale utilizzo e in conformità alle prescrizioni riportate nel manuale d'uso del prodotto; sarà altresì riconosciuta valida, qualora il prodotto in questione non sia stato in alcun caso alterato ed utilizzato esclusivamente in abbinamento a parti e componenti HAYWARD. Gli eventuali danni dovuti a gelo e ad attacchi di agenti chimici non sono coperti da garanzia.

Ogni altra spesa (trasporto, manodopera...) è esclusa dalla garanzia.

HAYWARD declina ogni responsabilità per danni, diretti o indiretti, riconducibili a installazione, collegamento o utilizzo non corretti del prodotto.

Per richiedere un intervento in garanzia e la riparazione o la sostituzione di un componente, rivolgersi ad un rivenditore autorizzato. Salvo previo accordo scritto, gli eventuali resi saranno respinti.

I componenti soggetti ad usura non sono coperti dalla garanzia.

### 6.6 Fine vita dell'apparecchio



Il simbolo del cestino sbarrato relativo al trattamento e al recupero dei rifiuti elettrici ed elettronici significa che in nessun caso i prodotti devono essere gettati insieme ai rifiuti domestici, agli ingombranti o in discarica.

A fine vita, l'apparecchio deve essere messo nella raccolta differenziata per il riciclaggio o il recupero. Per questa tipologia di prodotti è previsto un circuito specifico di recupero nei paesi dell'Unione europea e in Norvegia.

Contattare l'installatore o il rappresentante locale per la raccolta, lo smantellamento e il riciclaggio di questo apparecchio.

Il ritrattamento del liquido refrigerante, dell'olio e degli altri pezzi deve essere realizzato da un professionista qualificato e autorizzato nel rispetto delle legislazioni locali e nazionali in vigore.

Se il prodotto contiene pile su cui è raffigurato questo simbolo, significa che le pile possono contenere sostanze nocive o inquinanti. In questo caso, smaltire le pile in un punto di raccolta per pile esauste.

*Pagina lasciata intenzionalmente bianca*



# HAYWARD<sup>®</sup>

## *FULL INVERTER*

VARMEPUMPE TIL SVØMMEBASSENG



HP5091DT3HA	HP5111DT3HA	HP5151DT3HA	HP5181DT3HA
-------------	-------------	-------------	-------------

**Installerings- og brukerveiledning**

# INNHOLD

<b>1. GENERELLE FORHOLDSREGLER - SIKKERHET</b>	<b>1</b>
<b>2. SPESIFIKASJONER</b>	<b>5</b>
2.1 Varmepumpens ytelse	5
2.2 Driftsområde	6
2.3 Dimensjoner	7
<b>3. INSTALLERING OG TILKOBLING</b>	<b>8</b>
3.1 Skjematisk diagram	8
3.2 Varmepumpe	8
3.3 Vanntilkobling	10
3.4 Elektrisk tilkobling	11
3.5 Førstegangs oppstart	12
3.6 Innstilling av vannstrømmen	14
<b>4. BRUKERGRENSESNITT</b>	<b>15</b>
4.1 Oversikt	15
4.2 Justering av dato og klokkeslett	17
4.3 Innstilling av Timer Start/Stans	18
4.4 Innstilling av settpunkt	20
4.5 Låse og låse opp berøringsskjermen	21
4.6 Innstilling av funksjon SILENCE	22
<b>5. VEDLIKEHOLD OG VINTERKLARGJØRING</b>	<b>25</b>
5.1 Vedlikehold	25
5.2 Vinterklargjøring	25
<b>6. VEDLEGG</b>	<b>26</b>
6.1 Koblingsskjemaer	26
6.2 Kobling med prioritet på enfaset varmpumpe	28
6.3 Sprengskisse og reservedeler	30
6.4 Veiledning for feilsøking	34
6.5 Garanti	37
6.6 Apparatet ved endt levetid	37

Vennligst les nøye og ta vare på for fremtidig referanse.

Dette dokumentet må være levert til svømmebassengets eier, og må oppbevares på et trygt sted.

# 1. GENERELLE FORHOLDSREGLER - SIKKERHET

Takk for at du har kjøpt denne Hayward varmpumpen til svømmebasseng. Hayward FULL INVERTER varmpumpe har blitt utformet i henhold til strenge produktionsstandarder for å oppfylle det høye kvalitetsnivået.

Hayward varmpumper vil gi deg enestående ytelser gjennom hele badesesongen ved at de tilpasser effekt, elektrisk forbruk og støynivå etter bassengets oppvarmingsbehov takket være kontrolllogikken FULL INVERTER.



*Les instruksene i denne veiledningen nøye før du tar enheten i bruk.*

Denne brukerveiledningen inneholder all nødvendig informasjon vedrørende installasjon, feilretting og vedlikehold.

Les denne brukerveiledningen nøye før du åpner enheten eller utfører vedlikeholdsoperasjoner på den. Produsenten av dette produktet vil ikke i noen tilfeller bli holdt ansvarlig for skader på brukeren eller ødeleggelser på enheten som er en følge av feil ved installasjon, feilretting eller unødvendig vedlikehold. Det er svært viktig at instruksene i denne brukerveiledningen blir nøye fulgt på ethvert tidspunkt.

Etter å ha lest denne brukerveiledningen, ta vare på den for senere referanse.

## Godkjent personell

- Installasjon, elektriske koblinger, vedlikehold og reparasjon av dette apparatet skal gjøres av godkjent fagperson i overensstemmelse med gjeldende lovtekster og etter de faglige regler som gjelder i landet der apparatet er installert (jf. § 3.4). For ethvert arbeid som skal gjøres på kjølekretsløpet skal fagpersonen være godkjent for arbeid som berører kjølevæsker.  
For Frankrike:
  - Lavspennings- elektrisk installasjon i overensstemmelse med NF-C 15-100.
  - Lovverk om håndtering av kjølevæsker: Forskrift 2007/737 med påfølgende forordninger om bruk.

# 1. GENERELLE FORHOLDSREGLER (fortsetter)

## **Dette produktet inneholder kjølegassen R32**



*Dette apparatet inneholder R32.*

*Det må ikke brukes noe annet kuldemedium enn R32. Enhver annen gass blandet med R32 kan føre til unormalt høye trykk som igjen kan forårsake feil eller eksplosjon av rørene samt personskade.*

*Ved reparasjon eller vedlikehold skal man bruke kobberør som er i overensstemmelse med den franske normen NF EN 12375-1 eller med det europeiske direktivet om utstyr under trykk 97/23/CE.*

*Da varmpumpen er under trykk må man aldri forsøke å stikke hull på eller lodde rørene. Det er fare for eksplosjon.*

*Apparatet må ikke utsettes for flammer, gnister eller andre antenningskilder. Det vil kunne eksplodere og føre til alvorlige skader eller død.*

*For detektering av lekkasje av kjølevæske: Bruk ikke haloid-lampe eller annen detektor som bruker bar flamme. Man må unger ingen omstendigheter bruke potensielle antenneskilder.*

Dette produktet inneholder fluorholdige klimagasser som er gjeldende under Kyoto-protokollen. Disse gassene må ikke frigjøres i atmosfæren.

GWP-verdi<sup>(1)</sup> : 675. Verdi basert på 4. GIEC-rapport.

Sikkerhetsgruppe: A2L.

Mengden kuldemedium basert på regelverket F Gaz 517/2014 er angitt på dataplatten på enheten.

Ethvert arbeid på kjølesystemet skal gjøres av en godkjent fagperson som nevnt over.

Periodiske inspeksjoner av lekkasje av kuldemedium kan være nødvendig avhengig av europeisk eller lokalt regelverk. Vennligst kontakt din lokale forhandler for mer informasjon.

- Vær oppmerksom på at kjølemediet kan være luktfritt.
- Rørene må ikke stilles hull på eller varmes opp, da det er risiko for eksplosjon og alvorlige brannskader.
- Bruk ikke metoder for akselerering av avisings- eller rengjøringsprosessen som ikke anbefales av fabrikanten.
- Apparatet skal lagres i et lokale der det ikke befinner seg permanent fungerende kilder til antennelse (for eksempel nakne flammer, fungerende gassapparat eller elektrisk radiator).

(1) Globalt oppvarmingspotensial

# 1. GENERELLE FORHOLDSREGLER (fortsetter)

## Betingelser for installering

- Denne varmepumpen er kun beregnet for å varme opp bassengvann, og materiellet må ikke brukes til andre bruksområder.
- Prøv ikke å installere apparatet på egenhånd.
- Dersom du detekterer en feil eller en unormal situasjon, må ikke varmepumpen installeres, men ta umiddelbart kontakt med forhandleren.
- Dersom varmepumpen skal lagres må den oppbevares i et godt ventilert lokale med et gulvareal på mer enn  $A_{\min}$  (m<sup>2</sup>) gitt med følgende formel:  
$$A_{\min} = (M / (2.5 \times 0.22759 \times h_0))^2$$

M er mengden kuldemedium i apparatet i kg, og h<sub>0</sub> er lagringshøyden. For lagring på gulvet h<sub>0</sub> = 0,6 m.
- Produktet er utelukkende beregnet på bruk i hjemmet og installasjon utendørs. Luften som slippes ut av produktet må kunne sirkulere fritt, og skal ikke brukes til andre formål som for eksempel oppvarming eller nedkjøling av et rom eller en bygning.
- Kontroller strømledningen. Dersom strømledningen er ødelagt, må den byttes ut av fabrikanten, dennes serviceavdeling eller av en kvalifisert og godkjent fagperson.
- Apparatet skal jordes kontinuerlig, og dette er obligatorisk. Jordingsledningen skal være lenger enn de andre for å forebygge elektrisk støt dersom kabelen rives ut. Den elektriske installasjonen skal være utstyrt med en 30 mA differensialbeskyttelse (cf § 3.4).
- Sjekk at underlaget som er forutsett for enheten er riktig dimensjonert for vekten av apparatet.
- **Alle anbefalinger som ikke etterkommes vil oppeheve garantien.**

## Råd når det gjelder vedlikehold

Vedlikeholdsoperasjonene må utføres en gang i året for å sikre lang levetid og god drift av varmepumpen.

- Vedlikehold og drift må utføres til anbefalte tidspunkt, som oppgitt i denne brukerveiledningen.
  - Bruk kun originale reservedeler.
  - Kontroller strømledningen. Dersom strømledningen er ødelagt, må den byttes ut av fabrikanten, dennes serviceavdeling eller av en kvalifisert og godkjent fagperson.
  - Sjekk at apparatet er jodet kontinuerlig.
  - Rengjør fordampere med en myk børste eller med en luft- eller vannstråle.
- NB! Bruk aldri høytrykksspyler.**

# 1. GENERELLE FORHOLDSREGLER (fortsetter)

- Kontroller evakuering av kondensat.
- Kontroller at elektriske og hydrauliske koblinger sitter godt
- Kontroller vanntettheten til kondensatoren.
- La **en kvalifisert fagmann** sjekke tettheten på kjølekretsen ved hjelp av en lekkasje-detektor.



***Før alt vedlikehold må varmepumpen være frakoblet alle strømkilder. Vedlikeholdsoperasjoner skal bare utføres av personell som er kvalifisert til å håndtere kuldemedier.***

## Instruksjoner for overvintring

- Sett varmepumpen i "OFF"-modus.
- Slå av varmepumpens strømforsyning.
- Tøm kondensatoren ved hjelp av tømmeventilen for å unngå fare for degradering. (høy risiko for frost).
- Lukk bypassventilen og skru løs koblingsdelene til vanninnløp/vannutløp.
- Fjern maksimalt med stillestående vann som er igjen i kondensatoren ved hjelp av en blåsepistol.
- Forsegle varmepumpens vanninnløp og vannutløp for å hindre at fremmedlegemer kommer seg inn.
- Dekk til varmepumpen med vinterbelegget som er tiltenkt dette formålet.



***Alle skader som er forårsaket av uriktig vinterklargjøring vil ugyldiggjøre garantien.***

## Bruksbetingelser

Dette apparatet kan brukes av barn over 8 år samt av personer med reduserte fysiske, sensorielle eller mentale evner, eller av personer uten erfaring eller kunnskap, dersom disse personene er under korrekt overvåking eller dersom de har fått instruksjoner om sikker bruk av apparatet, og dersom det blir tatt hensyn til all risiko.

Barn skal ikke leke med dette apparatet.

Rengjøring og vedlikehold skal ikke gjøres av barn som ikke er under overvåking.



## 2. SPESIFIKASJONER

### 2.1 Varmepumpens ytelse

Modeller	FULL INVERTER	HP5091DT3HA	HP5111DT3HA	HP5151DT3HA	HP5181DT3HA
Tilførselsspennning	V	220V-240V ~ / 1ph / 50Hz			
Kuldemedium	/	R32			
Last	kg	0,430	0,450	0,60	0,670
Masse i teqCO <sub>2</sub>	/	0,29	0,30	0,41	0,45
Hypppighet for lekkasjekontroll	/	Er ikke påkrevet, men årlig kontroll anbefales			
Oppvarmingskapasitet Min--Maks <sup>(a)</sup>	kW	2,46 -- 9,17	2,36 -- 11,45	3,31 -- 15,90	3,2 -- 18,15
Absorbert elektrisk effekt Min--Maks <sup>(a)</sup>	kW	0,17 -- 1,45	0,17 -- 1,80	0,27 -- 2,84	0,22 -- 3,13
Nominell strømverdi Min--Maks <sup>(a)</sup>	A	1,17 -- 6,42	1,19 -- 7,85	1,37 -- 12,35	1,45 -- 13,58
COP Maks--Min <sup>(a)</sup>	/	14,37 -- 6,32	13,88 -- 6,35	12,26 -- 5,59	14,34 -- 5,80
Oppvarmingskapasitet Min--Maks <sup>(b)</sup>	kW	1,75 -- 7,05	1,56 -- 8,00	3,05 -- 12,40	2,86 -- 14,11
Absorbert elektrisk effekt Min--Maks <sup>(b)</sup>	kW	0,27 -- 1,51	0,279 -- 1,74	0,42 -- 2,65	0,43 -- 2,99
COP Maks--Min <sup>(b)</sup>	/	6,40 -- 4,65	5,60 -- 4,80	7,26 -- 4,68	6,63 -- 4,71
Maksimum strømverdi	A	8,40	9,50	14	15,9
Sikringsstørrelse	aM	10	12	16	20
Effektbryter Kurve D	D	10	12	16	20
Startstrøm	A	< Maksimum strømverdi			
Hydraulisk tilkoping	mm	50 mm			
Nominell vannstrøm <sup>(a)</sup>	m <sup>3</sup> /h	4,00	5,00	6,70	7,70
Fall i vanntrykk (maks.)	kPa	3,80	4,0	6,3	10
Kompressor	/	DC Inverter Panasonic		DC Inverter Mitsubishi	
Type	/	Dobbeltroterende		Dobbeltroterende	
Antall	/	1			
Svingningsmotstand ved 20°C	Ohm	1,208		0,95	
Vifte	/	Aksial			
Antall		1			
Diameter	mm	405		510	
Antall rotor	/	3			
Motor	/	DC-omformer			
Antall	/	1			
Rotasjonshastighet	Omdr/min	400 -- 700	500 -- 850	300 -- 750	400 -- 750
Hastighet i Silent Mode	Omdr/min	400	500	300	400
Lydtrykknivå ved 1 m	dB(A)	50,2	53,9	50,8	54,0
Lydtrykknivå ved 10 m	dB(A)	32,8	34,2	33,8	37,25
Enhetens dimensjoner, netto (L-I-H)	mm	1003 / 418 / 605		1048 / 437 / 768	1161 / 473 / 862
Vekt	kg	44	45	66	70

(a) Tørrluft 27°C – Relativ fuktighet 78% - Temperatur til vanninnløp 26°C.



(b) Tørrluft 15°C – Relativ fuktighet 71% - Temperatur til vanninnløp 26°C.

## 2. SPESIFIKASJONER (fortsetter)

---

### 2.2 Driftsområde

Bruk varmepumpen i de følgende temperatur- og fuktighetsområder for å sikre en trygg og effektiv drift.

	Oppvarmingsmodus 	Kjølemodus 
Utetemperatur	-7°C – +35°C	+7°C – +43°C
Vanntemperatur	+12°C – +32°C	+8°C – +40°C
Relativ luftfuktighet	< 80%	< 80%
Innstillingsområde for settpunkt	+15°C – +32°C	+8°C – +32°C



***Hvis temperatur eller luftfuktighet ikke samsvarer med disse betingelsene, kan sikkerhetsanordninger aktiveres og varmepumpen slutte å fungere.***



***Maksimumstemperaturen for oppvarming er begrenset til 32°C for å unngå forringelse av foringene. Hayward fraskriver seg alt ansvar i tilfelle av en bruk utover 32°C.***

## 2. SPESIFIKASJONER (fortsetter)

### 2.3 Dimensjoner

Modeller:

HP5091DT3HA / HP5111DT3HA / HP5151DT3HA / HP5181DT3HA

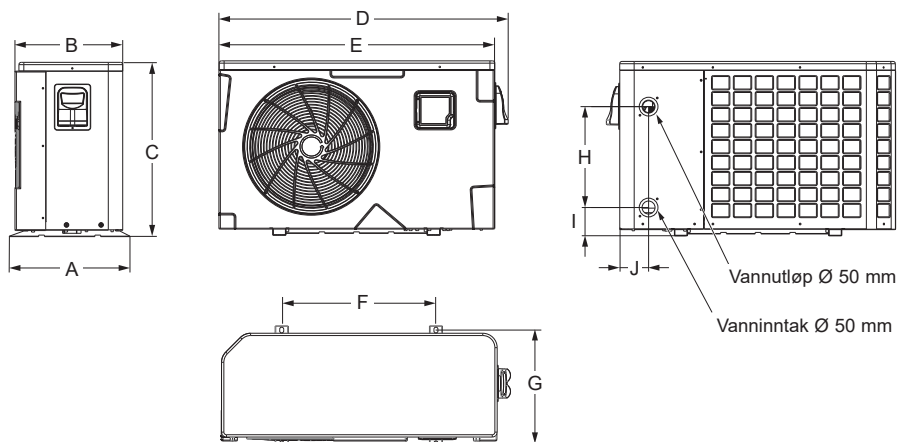

Enhet: mm

Model	HP5091DT3HA / HP5111DT3HA	HP5151DT3HA	HP5181DT3HA
<b>A</b>	418	436,5	473
<b>B</b>	374	418	451,5
<b>C</b>	604,5	767,5	862
<b>D</b>	1003	1047,5	1160,5
<b>E</b>	956	1002	1115
<b>F</b>	535	615	790
<b>G</b>	394,5	410	447
<b>H</b>	350	350	466
<b>I</b>	97,7	101,2	97,6
<b>J</b>	99,2	106,5	113,5

## 3. INSTALLERING OG TILKOBLING

### 3.1 Skjematisk diagram

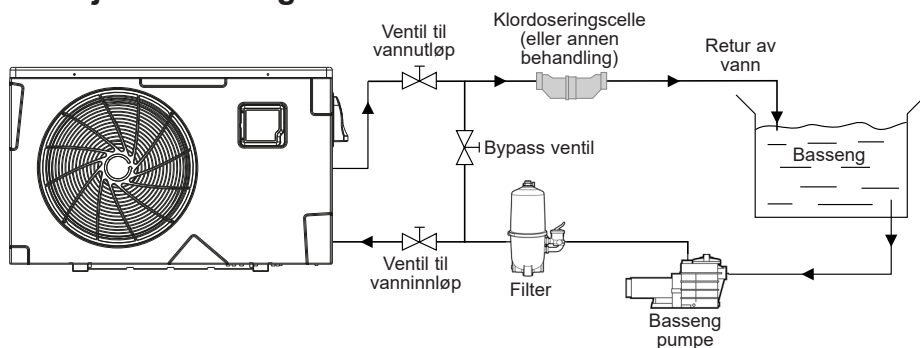

Merk: Varmepumpen er levert uten noe utstyr for behandling eller filtrering. Elementene som presenteres i diagrammer er deler som må leveres av installatøren.

### 3.2 Varmepumpe



**Plasser varmpumpen utendørs, og ikke i lukkede tekniske lokaler.**

**Velg helst et sted i solen og i ly for dominerende vind.**

**Apparatet skal være lett tilgjengelig for installering eller vedlikehold som skal gjøres på et senere tidspunkt.**

**Plassert under beskyttelse, må minsteavstander angitt nedenfor følges for å unngå resirkulering av luft, og en degradering av varmpumpens i totale prestasjoner.**

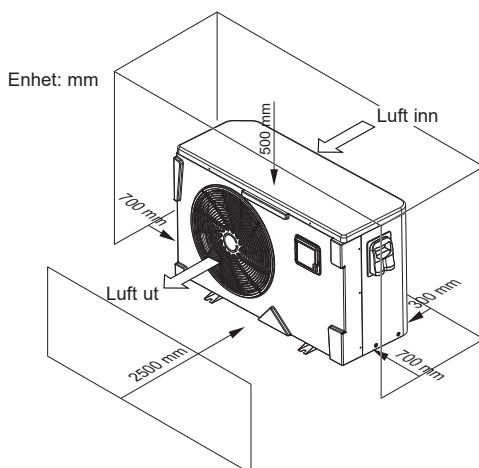

### 3. INSTALLERING OG TILKOBLING (fortsetter)



Apparatet må ikke plasseres rett på bakken da den kan forårsake forstyrrelser. Ved plassering på bakken skal man privilegerer bruk av vibrasjonsabsorbatorer. Man skal ikke bruke veggfeste under omstendigheter som kan viderebringe vibrasjoner. Varmepumpen må ikke installeres på et underlag som risikerer å forsterke enhetens vibrasjoner.

Varmepumpen må ikke installeres på et sted hvor støynivået vil kunne forsterkes, eller på et sted hvor støyen fra enheten vil kunne være til sjenanse for naboene.

Bruk ikke teip, da det ikke er å anse som pålitelige festesystemer.

Varmepumpen skal aller helst installeres på en betongplate som er flat og desolidarisert.

Monter varmpumpen på de medfølgende Silentbloc-underlagene (skruer og skiver inkludert).

Fest apparatet ved å overholde reglene for tilstramming som angis, dette for å unngå all risiko for ulykke eller skade på materiell og personer. En annen mulighet er å installere varmpumpen på et gummi-underlag ved hjelp av tilpassede skruer (følger ikke med).

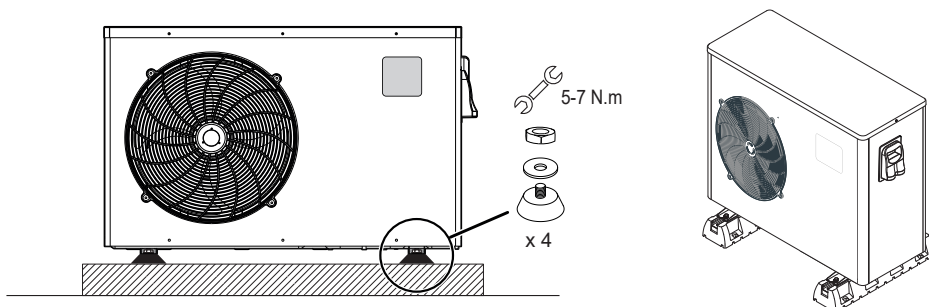

Maksimal avstand for installasjon mellom varmpumpen og bassenget 15 meter.

Total tur-retur lengde for vannkanalene 30 meter.

Isoler vannkanaler på bakken og under jorden.

Varmepumpen må bygges opp og installeres med en minimum avstand fra bassenget, i henhold til standard NF C 15-100 (minst 3,5 meter fra bassenget i Frankrike) eller i henhold til gjeldende regler og forskrifter i hvert enkelt land.

Varmepumpen må ikke installeres i nærheten av en varmekilde.

I land hvor det er mye snø, bør det bygges opp et tak over maskinen for å unngå at snø bygger seg over ribbene på varmpumpen.

## 3. INSTALLERING OG TILKOBLING (fortsetter)

---

### 3.3 Vanntilkobling

Varmepumpen leveres med to koblingsdeler med diameter på 50 mm. Bruk PVC-rør på Ø 50 mm for vannkanaler. Koble varmpumpens vanninnløp til kanalen fra filteringsenheten, og koble deretter varmpumpens vannutløp til kanalen som går til bassenget (se diagram nedenfor).

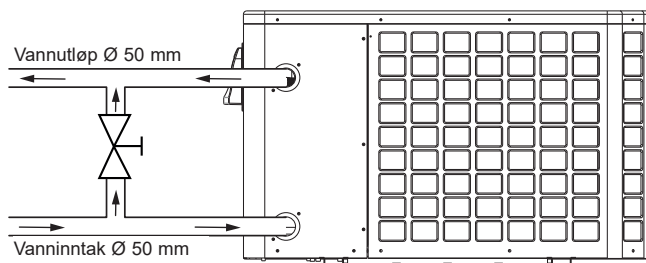

Installer en bypassventil mellom varmpumpens vanninnløp og vannutløp.



***Dersom automatisk fordeler eller klordoseringscelle benyttes, må det være installert etter varmpumpen, for å beskytte Titanium-kondensatoren mot en for stor konsentrasjon av kjemiske stoffer.***



***Sørg for å installere bypassventilen og de medfølgende koblingsdelene ved enhetens vanninnløp og vannutløp, for å forenkle tømning om vinteren, for å forenkle tilgang eller demontering for vedlikehold.***

## 3. INSTALLERING OG TILKOBLING (fortsetter)

### 3.4 Elektrisk tilkobling



**Den elektriske installasjonen og kabling av dette utstyret må være i overensstemmelse med lokale forskrifter for installasjoner.**

F	NF C15-100	GB	BS7671:1992
D	DIN VDE 0100-702	EW	EVHS-HD 384-7-702
A	ÖVE 8001-4-702	H	MSZ 2364-702/1994/MSZ 10-553 1/1990
E	UNE 20460-7-702 1993, RECBT ITC-BT-31 2002	M	MSA HD 384-7-702.S2
IRL	Wiring Rules + IS HD 384-7-702	PL	PN-IEC 60364-7-702:1999
I	CEI 64-8/7	CZ	CSN 33 2000 7-702
LUX	384-7.702 S2	SK	STN 33 2000-7-702
NL	NEN 1010-7-702	SLO	SIST HD 384-7-702.S2
P	RSIUEE	TR	TS IEC 60364-7-702



**Kontroller at den tilgjengelige strømforsyningen og nettfrekvensen stemmer overens med operasjonelle krav, og tar hensyn til den spesifikke plasseringen til apparatet, og nødvendig strøm til å drive alle andre apparater som er koblet til samme krets.**

**HP5091DT3HA / HP5111DT3HA / HP5151DT3HA / HP5181DT3HA  
230V ~ +/- 10 % 50 Hz 1 Fase**

**Følg tilsvarende koblingsskjema i vedlegg.**

**Koblingsboksen ligger på enhetens høyre side. Tre tilkoblinger er til strømforsyning, og to til å styre filtreringspumpen (servomekanisme).**

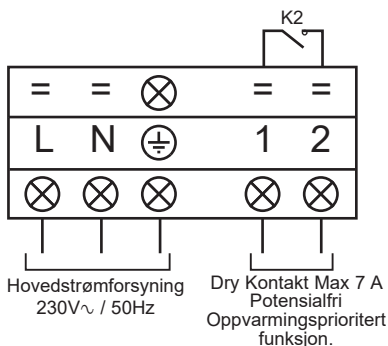

### 3. INSTALLERING OG TILKOBLING (fortsetter)

---



**Man må under ingen omstendigheter bruke et elektrisk støpsel til strømtilførselen.**

**Den elektriske strømtilførselslinjen skal være riktig utstyrt med en all-pol beskyttelse av typen bryter med D-kurve og med en beskyttende differensialbryter på 30 mA (se tabell nedenfor).**

Modeller		HP5091DT3HA	HP5111DT3HA	HP5151DT3HA	HP5181DT3HA
Elektrisk strømforsyning	V/Ph/Hz	230V~ 50Hz	230V~ 50Hz	230V~ 50Hz	230V~ 50Hz
Effektbryter Kurve D	A	8 D	10 D	16 D	20 D
Kabelseksjon	mm <sup>2</sup>	3G 2,5	3G 2,5	3G 2,5	3G 4



**Bruk en kabel av typen RO 2V / R 2V eller tilsvarende.**



**Kabelseksjonene er gitt for en lengde på maksimalt 25 meter. De må allikevel kontrolleres og tilpasses de gjeldende installasjonsforholdene.**



**Pass alltid på å stanse hovedstrømforsyningen før du åpner den elektriske kontrollboksen.**

**Etter brudd på strømtilførselen, vent i 10 minutter før du får tilgang til de interne, aktive delen i utstyret (energi som lagres i kondensatorene).**

#### 3.5 Førstegangs oppstart

Oppstartsprosedyre - når installasjonen er fullført bør du gjøre følgende:

- 1) Roter viften for hånd for å sikre at den kan rotere fritt for hånd, og at spiralen er riktig festet til motorakselen.
- 2) Se til at enheten er riktig tilkoblet til hovedstrømforsyningen (se koblingsskjema i vedlegg).
- 3) Slå på filtreringspumpen.
- 4) Se til at alle vannventiler er åpne og at vannet renner inn i enheten før varme eller avkjøling skrus på.
- 5) Sjekk at kondensutløpet er festet riktig og er fri for blokkeringer.
- 6) Aktiver enhetens strømforsyning og trykk på On/Off-knappen  på kontrollpanelet.
- 7) Se til at ingen alarm- eller låsesymboler vises. Dersom det motsatte skulle være tilfellet, se veiledningen for feilsøking (se § 6.4).



### 3. INSTALLERING OG TILKOBLING (fortsetter)

---

- 8) Fastsett vannstrømmen ved hjelp av bypassventilen (se kapittel 3.6 og 2.1), som angitt for hver modell, slik at du oppnår en temperaturforskjell på 2 °C mellom vanninnløp og vannutløp.
- 9) Etter den har stått på noen minutter, sjekk at luften som kommer ut av enheten er kjøligere (mellom 5-10 °C).
- 10) Slå av filtreringspumpen mens enheten er i drift. Enheten skrur også av automatisk og viser feilkoden E03.
- 11) La enheten og filtreringspumpen stå på hele døgnet helt til ønsket vanntemperatur er nådd. Enheten slås av når gitt temperatur for vanninnløp er nådd. Enheten vil nå automatisk restarte (så lenge filtreringspumpen er på) når vanntemperaturen blir 2 °C mindre enn angitt temperatur.

**Vannsirkulasjonsbryter** - Enheten er utstyrt med en bryter som aktiverer varmpumpen når filtreringspumpen er på, og skrur den av når pumpen skrur av. Ved mangel på vann, vises alarmkoden E03 på kontrolleren (Se kapittel 6.4).

**Tidsforsinkelse** - enheten er utstyrt med en innebygd 3-minutters omstartsforsinkelse for å beskytte kontrollkretsens deler og for å fjerne omstartssyklus og støy. Denne tidsforsinkelsen vil automatisk omstarte enheten ca. 3 minutter etter hver avbrytelse av kontrollkretsen. Selv et kort strømavbrudd vil aktivere tidsforsinkelsen og forhindre enheten fra å starte før nedtellingen på 3 minutter er over.

### 3. INSTALLERING OG TILKOBLING (fortsetter)

---

#### 3.6 Innstilling av vannstrømmen

Ventilene for vanninnløp og vannutløp er åpne, juster bypassventilen for å få en temperaturforskjell på 2 °C mellom vanninnløp og vannutløp (se skjematisk diagram kapittel 3.1).

Du kan kontrollere innstillingen ved å se på temperaturene for innløp/utløp direkte på kontrollpanelet.



**Merk:** Åpningen av bypassventilen genererer en mindre viktig strømning eller økt  $\Delta T$ .

Lukking av bypassventilen genererer en sterkere strømning, eller en nedgang i  $\Delta T$ .

## 4. BRUKERGRENSESNIITT

### 4.1 Oversikt

Varmepumpen er utstyrt med et digitalt kontrollpanel med berøringsskjerm, elektrisk tilkoblet og forhåndsinnstilt i fabrikk til varmedrift.

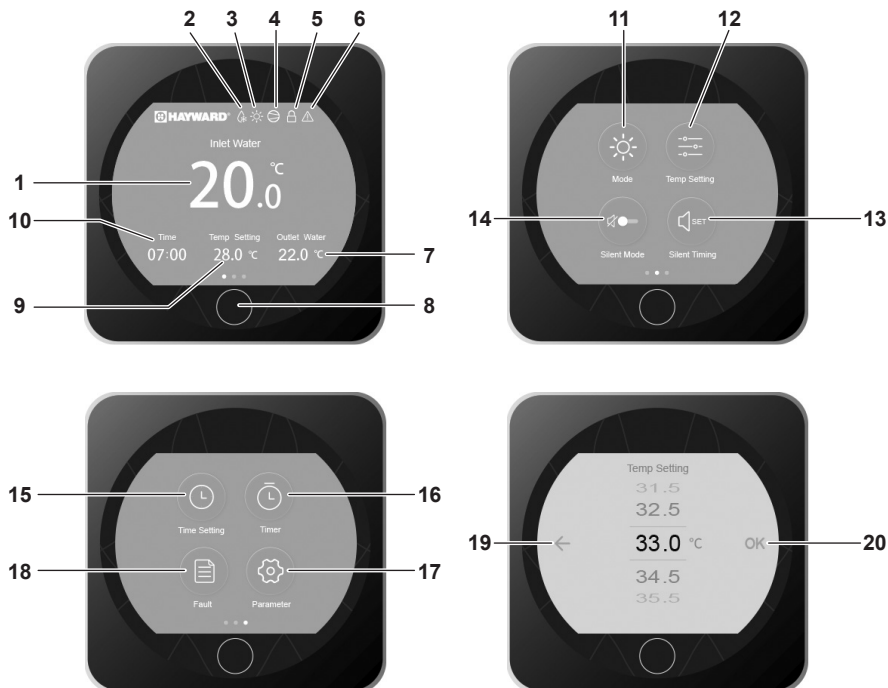

### Tegnforklaring

1	Temperatur Utgang av vann
2	Opptining på gang
3	Driftsmodus
4	Lampe for drift av kompressor
5	Låsing av skjerm
6	Alarm
7	Temperatur Inngang av vann
8	Start/Stans/Retur
9	Settpunkttemperatur
10	Klokkeslett

11	Valg av driftsmodus
12	Innstilling av settpunkt
13	Réglage Timer mode silence
14	Aktivering av Silent Mode
15	Innstilling av dato og klokkeslett
16	Innstilling av Timer Start/Stans
17	Tilgang til avanserte parametre
18	Tilgang til feilliste
19	Retur (uten validering)
20	Validering

## 4. BRUKERGRENSESNITT (fortsetter)

---

### OFF-modus

Når varmpumpen er stanset (i standby), vil teksten OFF vises på skjermen.

En sort skjerm angir at varmpumpen er stanset, og det er mulig å stille inn parametrene i denne modusen.



### ON-modus

Når varmpumpen er i drift eller under regulering (for å oppnå settpunktet), blir skjermen blå.





For å skifte fra OFF-modus til ON-modus og omvendt, trykk på tasten .

## 4. BRUKERGRENSESNITT (fortsetter)

### 4.2 Justering av dato og klokkeslett

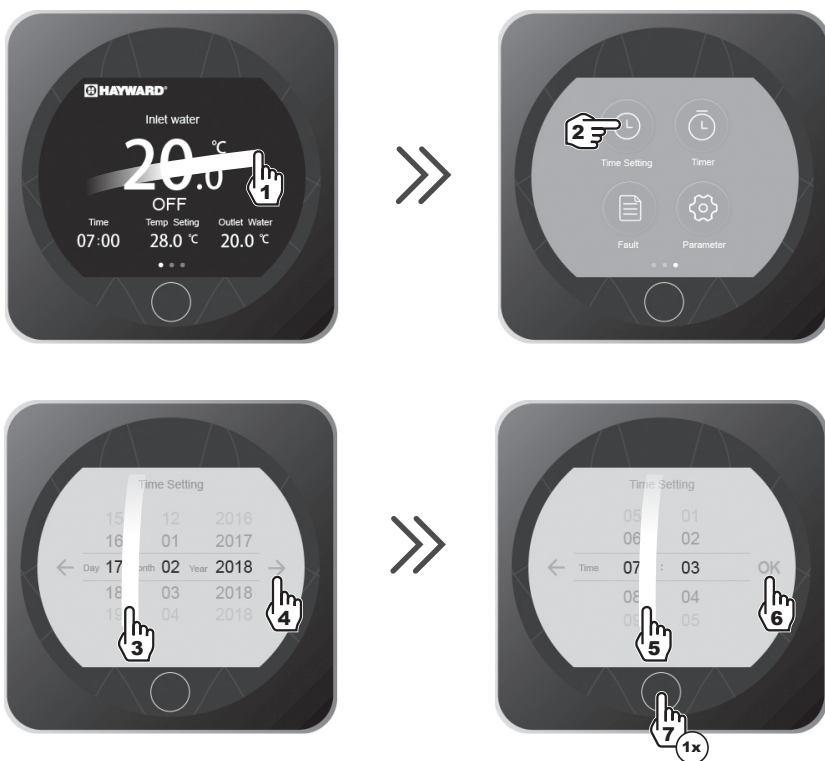
Innstilling av dato og klokkeslett kan utføres både i ON- og OFF-modus.



- Trykk 1 gang på  for å gå tilbake til hovedskjermen.

## 4. BRUKERGRENSESNITT (fortsetter)

### 4.3 Innstilling av Timer Start/Stans

Du stiller inn på denne funksjonen hvis du ønsker å sette varmepumpen i drift i løpet av en kortere periode enn den som er fastsatt av filtreringstimeren. Slik kan du programmere en forsinket start og en tidligere stans, eller rett og slett forby en tidsinnstilling for drift (for eksempel om natten).

Du kan programmere 1 Start-timere og 1 Stopp-timere.  
Justeringstrinnet er fra “time til time”.



## 4. BRUKERGRENSESNITT (fortsetter)

---



**Blå markering = Aktivert**  
**Nedtonet = Deaktivert**

- Trykk 2 ganger på  for å gå tilbake til hovedskjermen.

## 4. BRUKERGRENSESNITT (fortsetter)

### 4.4 Innstilling av settpunkt

Innstilling av settpunkt kan utføres både i ON- og OFF-modus med en nøyaktighet på 0,5°C.



- Trykk 1 gang på  for å gå tilbake til hovedskjermen.



**Det anbefales å ikke overstige en temperatur på 30 °C for å unngå forandring i basseng-liners.**



## 4. BRUKERGRENSESNITT (fortsetter)

### 4.5 Låse og låse opp berøringsskjermen

Låsing og opplåsing av skjermen kan utføres både i ON- og OFF-modus.



Låsing aktivert



Låsing deaktivert

## 4. BRUKERGRENSESNITT (fortsetter)

### 4.6 Innstilling av funksjon SILENCE

I Silence-modus kan du bruke varmepumpen i økonomisk modus, på lavt lydnivå, dersom oppvarmingsbehovet ikke er sterkt (hvis vanntemperaturen kun skal holdes jevn, eller hvis du trenger å ha stillegående drift).

Denne funksjonen kan aktiveres/deaktiveres enten manuelt eller ved hjelp av en tidtaker.

#### Aktivering / Deaktivering



Silent mode deaktivert



Silence-modus er aktivert



- Trykk 1 ganger på  for å gå tilbake til hovedskjermen.

## 4. BRUKERGRENSESNITT (fortsetter)

---

### Innstilling av Timer for SILENT mode



## 4. BRUKERGRENSESNITT (fortsetter)

---



- Trykk 2 ganger på  for å gå tilbake til hovedskjermen.



**Justeringstrinnet er fra "time til time".  
Når Timeren er aktivert, er den aktiv hele uka.**

## 5. VEDLIKEHOLD OG VINTERKLARGJØRING

---

### 5.1 Vedlikehold

Disse vedlikeholdsoperasjonene må utføres en gang i året for å sikre lang levetid og god drift av varmpumpen.

- Vedlikehold og reparasjon av dette apparatet skal gjøres av godkjent fagperson i overensstemmelse med gjeldende lovtekster og etter de faglige regler som gjelder i landet der apparatet er installert (jf. § 3.4). For ethvert arbeid som skal gjøres på kjølekretsløpet skal fagpersonen være godkjent for arbeid som berører kjølevæsker.
- Kontroller strømledningen. Dersom strømledningen er ødelagt, må den byttes ut av fabrikanten, dennes serviceavdeling eller av en kvalifisert og godkjent fagperson.
- Sjekk at apparatet er jodet kontinuerlig.
- Rengjør fordampere med en myk børste eller med en luft- eller vannstråle. **NB! Bruk aldri høytrykksspyler.**
- Kontroller evakuering av kondensat.
- Kontroller at elektriske og hydrauliske koblinger sitter godt
- Kontroller vann tettheten til kondensatoren.
- La **en kvalifisert fagmann** sjekke tettheten på kjølekretsen ved hjelp av en lekkasje-detektor.



***Før alt vedlikehold må varmpumpen være frakoblet alle strømkilder. Vedlikeholdsoperasjoner skal bare utføres av personell som er kvalifisert til å håndtere kuldemedier.***

### 5.2 Vinterklargjøring

- Sett varmpumpen i "OFF"-modus.
- Slå av varmpumpens strømforsyning.
- Tøm kondensatoren ved hjelp av tømmeventilen for å unngå fare for degradering. (høy risiko for frost).
- Lukk bypassventilen og skru løs koblingsdelene til vanninnløp/vannutløp.
- Fjern maksimalt med stillestående vann som er igjen i kondensatoren ved hjelp av en blåsepistol.
- Forsegle varmpumpens vanninnløp og vannutløp for å hindre at fremmedlegemer kommer seg inn.
- Dekk til varmpumpen med vinterbelegget som er tiltenkt dette formålet.



***Alle skader som er forårsaket av uriktig vinterklargjøring vil ugyldiggjøre garantien.***



## 6. VEDLEGG (fortsetter)

### HP5151DT3HA / HP5181DT3HA

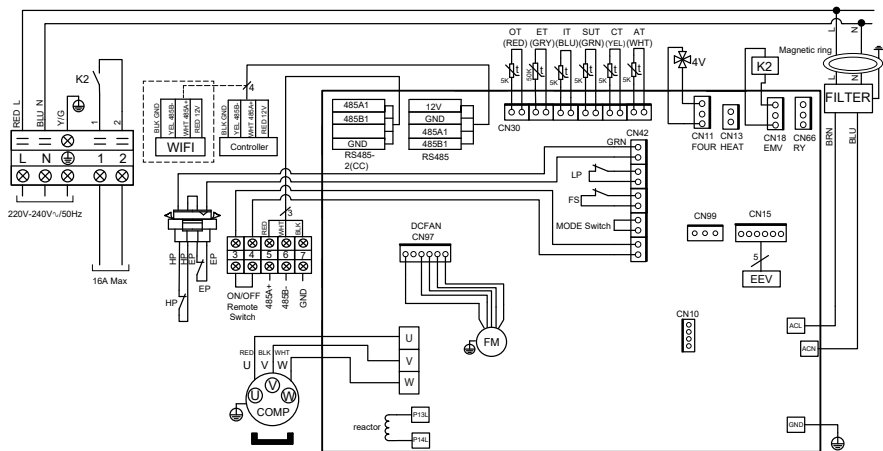

#### MERKNADER

**AT** : SENSOR FOR LUFTEMPERATUR

**COMP** : KOMPRESSOR

**CT** : SENSOR FOR FORDAMPET TEMPERATUR

**EEV** : ELEKTRONISK EKSPANSJONSVENTIL

**FM** : VIFTEMOTOR

**FS** : VANNSENSOR

**HP** : HØYTRYKKSBRUYTER

**IT** : TEMPERATURSENSOR TIL VANNINNLØP

**LP** : LAVTRYKKSBRUYTER

**OT** : TEMPERATURSENSOR TIL VANNUTLØP

**SUT** : SENSOR FOR SUGETEMPERATUR

**4V** : 4-VEIS VENTIL

**K2** : POTENSIALFRI KONTAKT, MAKS. 16 A

**ET** : TEMPERATURSENSOR FOR UTLADNING

**---** : OPSJON

## 6. VEDLEGG (fortsetter)

### 6.2 Kobling med prioritet på enfaset varmpumpe

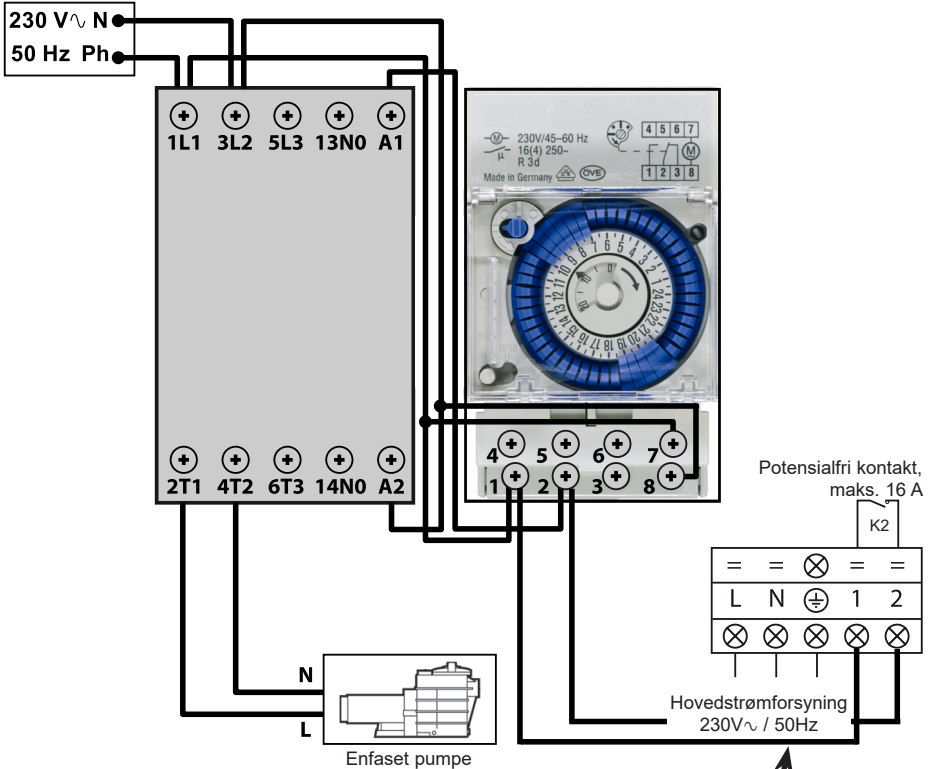

“Terminalene 1 og 2 gir et tørt kontaktpotensial uten polaritet 230 V  $\sim$  / 50 Hz.

Kabling til klemmene 1 og 2 i samsvar med ledningene beskrevet ovenfor, for å kontrollere driften av pumpen ved filtrering syklus 2 min hver time hvis temperaturen i tanken er under det innstilte punktet. “

 Aldri koble strømtilførselen til filterpumpen direkte på terminalene 1 og 2.





---

*Denne siden er blank med hensikt*

## 6. VEDLEGG (fortsetter)

### 6.3 Sprengskisse og reservedeler

HP5091DT3HA / HP5111DT3HA / HP5151DT3HA / HP5181DT3HA

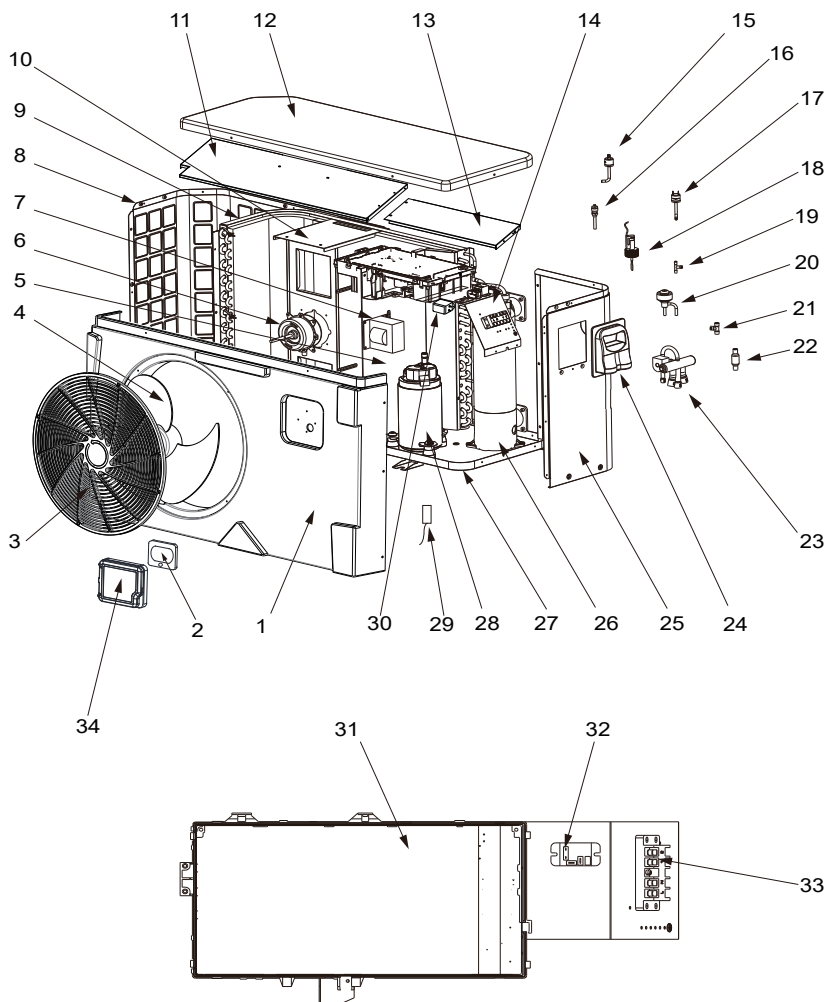

## 6. VEDLEGG (fortsetter)

Nr.	Betegnelse	Réf.	HP5091DT3HA	HP5111DT3HA	HP5151DT3HA	HP5181DT3HA
1	Fremre panel	HWX80900843	✓	✓	Gjelder ikke	Gjelder ikke
		HWX80900844	Gjelder ikke	Gjelder ikke	✓	Gjelder ikke
		HWX80900850	Gjelder ikke	Gjelder ikke	Gjelder ikke	✓
2	Controller LED	HWX72200070	✓	✓	✓	✓
3	Beskyttelsesgitter for viften	HWX80900375	✓	✓	✓	Gjelder ikke
		HWX20000220369	Gjelder ikke	Gjelder ikke	Gjelder ikke	✓
4	Vifteproppell	HWX301030000006	✓	✓	Gjelder ikke	Gjelder ikke
		HWX301030000001	Gjelder ikke	Gjelder ikke	✓	✓
5	/	/	/	/	/	/
6	Viftemotor DC	HWX80200018	✓	✓	Gjelder ikke	Gjelder ikke
		HWX20000330132	Gjelder ikke	Gjelder ikke	✓	✓
7	Spole 16 A 50 Hz 5 mH	HWX82500020	✓	✓	Gjelder ikke	Gjelder ikke
	Spole 20 A 50 Hz 5.2 mH	HWX82500021	Gjelder ikke	Gjelder ikke	✓	✓
8	Venstre panel	HWX80702123	✓	✓	Gjelder ikke	Gjelder ikke
		HWX80700244	Gjelder ikke	Gjelder ikke	✓	Gjelder ikke
		HWX80702268	Gjelder ikke	Gjelder ikke	Gjelder ikke	✓
9	Vinget fordampner	HWX80600042	✓	Gjelder ikke	Gjelder ikke	Gjelder ikke
		HWX80600043	Gjelder ikke	✓	Gjelder ikke	Gjelder ikke
		HWX80600044	Gjelder ikke	Gjelder ikke	✓	Gjelder ikke
		HWX80600078	Gjelder ikke	Gjelder ikke	Gjelder ikke	✓
10	Motorstøtte	HWX80700218	✓	✓	Gjelder ikke	Gjelder ikke
		HWX80700248	Gjelder ikke	Gjelder ikke	✓	Gjelder ikke
		HWX80700329	Gjelder ikke	Gjelder ikke	Gjelder ikke	✓
11	/	/	/	/	/	/
12	Øvre panel	HWX80900055	✓	✓	Gjelder ikke	Gjelder ikke
		HWX301090200806	Gjelder ikke	Gjelder ikke	✓	Gjelder ikke
		HWX80900076	Gjelder ikke	Gjelder ikke	Gjelder ikke	✓
13	/	/	/	/	/	/
14	/	/	/	/	/	/
15	Strømningsbegrenser NO 0.30 MPa / 0.15 MPa	HWX20000360157	✓	✓	✓	✓
16	Trykktilkobling 40 mm-1/2"	HWX20000140150	✓	✓	✓	✓
17	Høytrykkspressostat NC 3.2 MPa/4.4 MPa	HWX20013605	✓	✓	✓	✓
18	Sensor for vannstrømning	HWX83000068	✓	✓	✓	✓
19	T-format connector Ø 6.5-2 x Ø 6.5(T) x 0.75	HWX20001460	✓	✓	✓	✓
20	Elektronisk ekspansjonsventil	HWX81000011	✓	✓	Gjelder ikke	Gjelder ikke
		HWX81000013	Gjelder ikke	Gjelder ikke	✓	✓
21	T-format connector Ø 9.52-2 x Ø 6.35(T) x 1.0	HWX304030000002	✓	✓	✓	✓
22	Filter Ø 9.7-Ø 9.7 (Ø19)	HWX20000140178	✓	✓	Gjelder ikke	Gjelder ikke
	Filter Ø 9.7-Ø 9.7 (Ø28)	HWX20041444	Gjelder ikke	Gjelder ikke	✓	✓
23	4-veisventil	HWX20041437	✓	✓	✓	✓
24	Trappe elektrisk tilgang	HWX320922029	✓	✓	✓	✓
25	Høyre panel	HWX80700580	✓	✓	Gjelder ikke	Gjelder ikke
		HWX80700878	Gjelder ikke	Gjelder ikke	✓	Gjelder ikke
		HWX80700581	Gjelder ikke	Gjelder ikke	Gjelder ikke	✓
26	Kondensator Titanium/PVC	HWX72300013	✓	Gjelder ikke	Gjelder ikke	Gjelder ikke
		HWX72300014	Gjelder ikke	✓	Gjelder ikke	Gjelder ikke
		HWX72300010	Gjelder ikke	Gjelder ikke	✓	Gjelder ikke
		HWX72300024	Gjelder ikke	Gjelder ikke	Gjelder ikke	✓
27	/	/	/	/	/	/
28	Kompressor	HWX80100108	✓	✓	Gjelder ikke	Gjelder ikke
		HWX80100046	Gjelder ikke	Gjelder ikke	✓	✓

## 6. VEDLEGG (fortsetter)

HP5091DT3HA / HP5111DT3HA / HP5151DT3HA / HP5181DT3HA

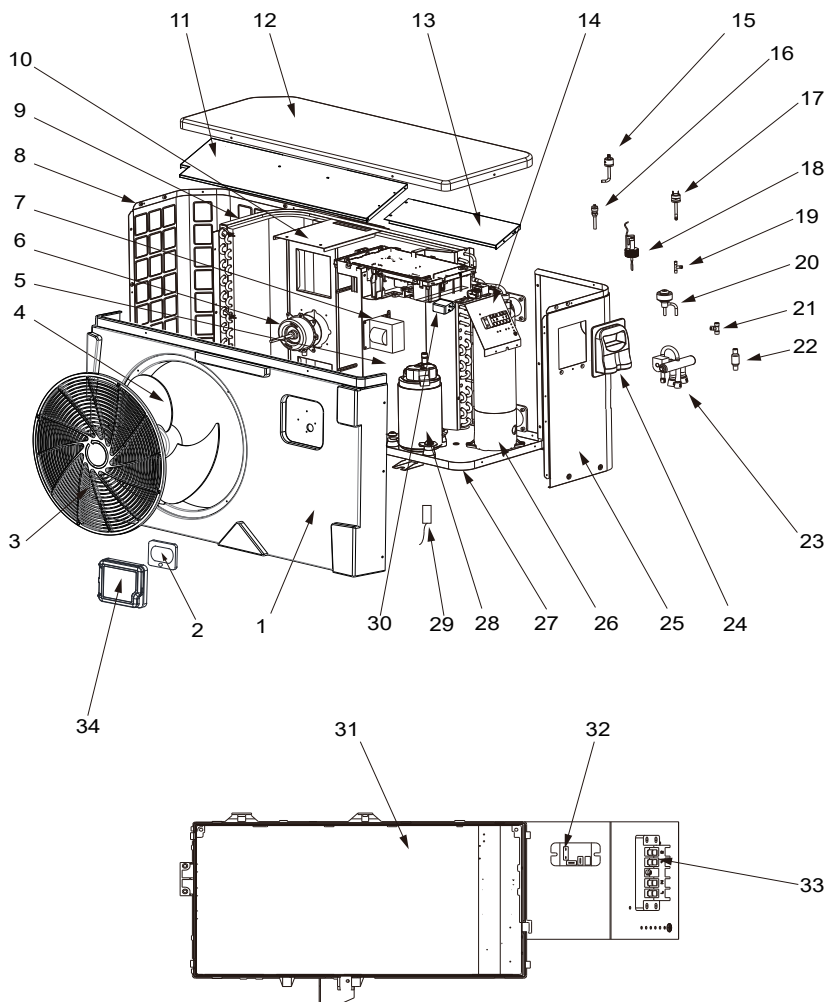

## 6. VEDLEGG (fortsetter)

Nr.	Betegnelse	Réf.	HP5091DT3HA	HP5111DT3HA	HP5151DT3HA	HP5181DT3HA
29	Kompressorsugesonde 5 k - 560 mm	HWX83000044	✓	✓	Gjelder ikke	Gjelder ikke
	Kompressorsugesonde 5 k - 760 mm	HWX83000053	Gjelder ikke	Gjelder ikke	✓	✓
	Lufttemperatur probe 5 k - 350 mm	HWX83000049	✓	✓	✓	✓
	Vannuttak probe 5 k - 410 mm	HWX83000050	✓	✓	✓	✓
	Vanninntak probe 5 k - 850 mm	HWX83000052	✓	✓	✓	Gjelder ikke
	Vanninntak probe 5 k - 980 mm	HWX83000055	Gjelder ikke	Gjelder ikke	Gjelder ikke	✓
	Kompressorutladningssonde 50 k - 660 mm	HWX83000026	✓	✓	✓	✓
	Avrimings sensor 5 k - 680 mm	HWX83000051	✓	✓	Gjelder ikke	Gjelder ikke
Avrimings sensor 5 k - 1040 mm	HWX83000045	✓	✓	✓	✓	
30	EMC Filter	HWX20003257	Gjelder ikke	Gjelder ikke	✓	✓
31	Elektronisk Driver-kort	HWX72200168AP3	✓	Gjelder ikke	Gjelder ikke	Gjelder ikke
		HWX72200168AP4	Gjelder ikke	✓	Gjelder ikke	Gjelder ikke
		HWX72200167AP5	Gjelder ikke	Gjelder ikke	✓	Gjelder ikke
		HWX72200167AP6	Gjelder ikke	Gjelder ikke	Gjelder ikke	✓
32	Relé K2	HWX20000360297	✓	✓	✓	✓
33	Terminal L-N-GND - 5 tilkninger 4 mm <sup>2</sup>	HWX40003901	✓	✓	✓	✓
34	Beskyttelsesdør	HWX80900321	✓	✓	✓	✓

## 6. VEDLEGG (fortsetter)

### 6.4 Veiledning for feilsøking





**Enkelte operasjoner må utføres av en kvalifisert tekniker.**

Ved feil på varmepumpen vises symbolet  øverst i venstre hjørne på skjermen.

Se tabellen lenger ned.



**Etter at problemet er blitt løst, vil det automatisk bli kvittert for feilen og trekanten forsvinner.**

- For å slette feillisten, trykk på  .
- Trykk 2 ganger på  for å gå tilbake til hovedskjermen.

## 6. VEDLEGG (fortsetter)

Feil	Feilkoder	Beskrivelse	Løsning
Feil i temperatursensor til vanninnløp	P01	Sensoren er åpen eller det er en kortslutning.	Sjekk kopplingsforbindelsen CN21/RES1 på kortet og konnektoren eller skift ut sensoren
Feil i temperatursensor til vannutløp	P02		Sjekk kopplingsforbindelsen N22/RES2 på kortet og konnektoren eller skift ut sensoren
Feil på avrimingssensor	P04		Sjekk kopplingsforbindelsen CN12/PH på kortet og konnektoren eller skift ut sensoren
Feil på sensor til utendørstemperatur	P05		Sjekk kopplingsforbindelsen CN8/OPT på kortet og konnektoren eller skift ut sensoren
Feil på kompressor aspirasjonssensor	P07		Sjekk kopplingsforbindelsen CN7/OAT på kortet og konnektoren eller skift ut sensoren
Feil på kompressorutladningsføler	P081		Sjekk kopplingsforbindelsen CN9/OHT på kortet og konnektoren eller skift ut sensoren
Høytrykksbeskyttelse	E01	Sensoren er åpen eller det er en kortslutning.	<p>Sjekk CN30/HP koblingen på kortet eller bytt sensor</p> <p>Sjekk vannmengden</p> <p>Sjekk detektoren for vannmengde</p> <p>Sjekk at ventilene er åpne</p> <p>Sjekk by-passventilen</p> <p>Sjekk at fordampere ikke er tett</p> <p>Vanntemperaturen er for høy</p> <p>Kondensproblemer etter vedlikeholdsarbeid, tøm hele kjølekretsen</p> <p>For stor væskemengde, tøm noe væske ut i en flaske</p>
Lavtrykksbeskyttelse	E02	Sensoren er åpen eller det er en kortslutning.	<p>Sjekk AI/DI03 koblingen på kortet eller bytt sensor</p> <p>Stor lekkasje med kjølevæske, foreta en lekkasjetest med detektor</p> <p>Luftmengden er for lav, sjekk hastigheten til vifterotasjonen</p> <p>Sjekk at fordampere ikke er tett, rengjør den på overflaten</p>
Feil i sensor for vannstrømning	E03	Sensoren er åpen eller det er en kortslutning.	<p>Sjekk AI/DI02 koblingen på kortet eller bytt sensor</p> <p>Ikke nok vann, sjekk filtreringspumpens drift</p> <p>Sjekk at vannkranene er åpne</p> <p>Sjekk justeringen av by-passventilen</p>

## 6. VEDLEGG (fortsetter)

Feil	Feilkoder	Beskrivelse	Løsning
Temperaturforskjellen mellom Innløp og Utløp >13°C	E06	Gjelder kun Kald-Modus	Ikke nok vann, sjekk filtreringspumpens drift
			Sjekk at vannkranene er åpne
			Sjekk justeringen av by-passventilen
Tinesyklus Kjølemodus	E07	Temperatur av utgående vann < 4°C	Stans varmepumpen, tøm kondensatoren, fare for frost
Kommunikasjonsfeil	E08	Ingen kommunikasjon mellom det elektroniske kortet og brukergrensesnittet	Sjekk kopleingene og kopplingsforbindelsene – se elektrisk diagram
Første nivå av frostbeskyttelse om vinteren	E19	2° < Vanntemperaturen < 4° og Lufttemperaturen < 0°	Stans varmepumpen, tøm kondensatoren, for å unngå frost. Som standard vil varmepumpen starte filtreringspumpen og varmepumpen for at ikke vannet skal fryse.
Andre nivå av frostbeskyttelse om vinteren	E29	Vanntemperaturen < 2° og Lufttemperaturen < 0°	Stans varmepumpen, tøm kondensatoren, for å unngå frost. Som standard vil varmepumpen starte filtreringspumpen og varmepumpen for at ikke vannet skal fryse.
Feil i viftemotor	F031	Motoren er blokkert eller forbindelsesfeil	Sjekk at det er fri rotasjon; sjekk kopplingsforbindelsene CN97/DCFan; skift ut motoren
Feil i viftemotor	F051	Forbindelsesfeil	Sjekk kopplingsforbindelsen DCFAN/CN97; skift ut motoren
For lav utendørs temperatur	TP	Driftgrensen er nådd	Slå av varmepumpen



## 6. VEDLEGG (fortsetter)

---

### 6.5 Garanti

#### GARANTIBETINGELSER

HAYWARD garanterer at deres produkter er fri for defekter i materiale og i utførelse for en periode på to år fra innkjøpsdato. Ved evt. garantikrav, må kvittering for kjøpet fremlegges. Vi ber om at kvitteringen blir tatt vare på av kjøper.

HAYWARD garanti er, etter HAYWARD eget valg, begrenset til erstatning eller reparasjon av defekte produkter som har vært i normal bruk og behandlet i henhold til instruksjonsboken, uten at det har vært foretatt endringer av produktet, og at bare ekte HAYWARD deler har vært brukt. Skader som skyldes frost og kjemiske reaksjoner er ikke omfattet av denne garanti.

HAYWARD er ikke ansvarlig for noen andre kostnader (flytting, arbeidskostnader osv...), heller ikke for direkte eller indirekte skader som skyldes funksjonsfeil ved et produkt.

For å sette i gang et garantikrav og å be om reparasjon eller erstatning av et produkt, vennligst ta kontakt med forhandleren. Forsendelse av produkter direkte til vår fabrikk blir ikke akseptert uten vår skriftlige forhåndsgodkjenning.

Slitasjedeler omfattes ikke av garantien.

### 6.6 Apparatet ved endt levetid



Symbolet som viser en søppelbøtte med strek over er knyttet til gjenvinning av elektrisk og elektronisk avfall, som betyr at produktene under ingen omstendigheter kan kastes sammen med vanlig søppel, på søppelfylling eller med spesialavfall.

■ Ved endt levetid skal apparatet kildesorteres for resirkulering eller gjenvinning. Det finnes et spesielt system for innsamling av denne typen produkter i EU og i Norge.

Kontakt installatøren eller dennes lokale representant for innsamling, demontering og resirkulering av apparatet.

Behandlingen av kjølevæsken, olje og andre deler skal gjøres av kvalifisert, godkjent fagperson i overensstemmelse med de lokale og nasjonale regler.

Dersom produktet inneholder batterier med dette symbolet, betyr det at batteriene kan inneholde farlige og forurensende substanser. Batteriene må da leveres inn til et spesielt innsamlingssted.

*Denne siden er blank med hensikt*



# **HAYWARD<sup>®</sup>**

## ***FULL INVERTER***

**ТЕПЛОВОЙ НАСОС ДЛЯ ПЛАВАТЕЛЬНОГО БАССЕЙНА**



HP5091DT3HA	HP5111DT3HA	HP5151DT3HA	HP5181DT3HA
-------------	-------------	-------------	-------------

**Руководство по монтажу и эксплуатации**

# СОДЕРЖАНИЕ

<b>1. ОБЩИЕ ИНСТРУКЦИИ - БЕЗОПАСНОСТЬ</b>	<b>1</b>
<b>2. ТЕХНИЧЕСКИЕ ХАРАКТЕРИСТИКИ</b>	<b>5</b>
2.1 Технические данные теплового насоса	5
2.2 Рабочий диапазон	6
2.3 Размеры	7
<b>3. УСТАНОВКА И ПОДКЛЮЧЕНИЕ</b>	<b>8</b>
3.1 Принципиальная Схема	8
3.2 Тепловой насос	8
3.3 Гидротехническое подключение	10
3.4 Электрическое Подключение	11
3.5 Первый запуск	12
3.6 Установка пропускной способности насоса	14
<b>4. ИНТЕРФЕЙС ПОЛЬЗОВАТЕЛЯ</b>	<b>15</b>
4.1 Общие сведения	15
4.2 Настройка даты и времени	17
4.3 Установка таймеров включения и выключения.	18
4.4 Установка заданного значения	20
4.5 Блокировка и разблокировка тактильного экрана	21
4.6 Настройка функции бесшумного режима SILENCE	22
<b>5. ТЕХНИЧЕСКОЕ ОБСЛУЖИВАНИЕ - ЗИМОВКА</b>	<b>25</b>
5.1 Техническое обслуживание	25
5.2 Консервация на зиму	26
<b>6. ПРИЛОЖЕНИЯ</b>	<b>27</b>
6.1 Электрические схемы	27
6.2 Включение подогрева в качестве приоритета	29
6.3 Вид в разборе и съемные элементы	30
6.4 Справочник по устранению неисправностей	34
6.5 Гарантия	37
6.6 Окончание срока службы устройства	37

Внимательно прочитать и сохранить для дальнейших консультаций.

Этот документ необходимо передать владельцу плавательного бассейна, чтобы он его сохранил в надежном месте.

# 1. ОБЩИЕ ИНСТРУКЦИИ - БЕЗОПАСНОСТЬ

---

Благодарим вас за покупку теплового насоса для бассейна Hayward. Тепловой насос Hayward FULL INVERTER был разработан согласно строгим производственным стандартам, чтобы соответствовать высочайшему уровню требуемого качества.

Тепловые насосы Hayward обеспечат невероятную производительность на протяжении всего купального сезона, регулируя мощность, энергопотребление и уровень шума, необходимые для подогрева бассейна, с помощью логической схемы контроля FULL INVERTER.



*Перед использованием устройства внимательно прочитайте инструкции, приведенные в этом руководстве.*

Это руководство включает в себя всю необходимую информацию, касающуюся установки, устранения неполадок и технического обслуживания.

Внимательно прочитайте это руководство, прежде чем открывать устройство или выполнять техническое обслуживание. Производитель данного продукта не будет нести ответственность в случае получения пользователем травмы или повреждения устройства из-за возможных ошибок во время установки, устранения неисправностей или неправильного технического обслуживания. Крайне важно всегда следовать инструкциям этого руководства.

После прочтения данного руководства держите его под рукой для дальнейшего использования.

## **Обученный персонал**

- Установка, электрические подключения, обслуживание и ремонт устройства должны выполняться квалифицированным специалистом в соответствии с нормативными документами и отраслевыми стандартами, действующими в стране, в которой устройство будет устанавливаться (см. § 3.4). Любые работы с холодильным контуром должен выполнять специалист, имеющий сертификат, подтверждающий право работы с хладагентами. Для Франции:
  - Низковольтная электроустановка в соответствии с NF-C 15-100.
  - Законодательство по обращению с хладагентами: Указ 2007/737 и постановления о порядке его применения.

## Это изделие содержит газообразный хладагент R32



**Это устройство содержит R32.**

**Используйте исключительно хладагент R32. Любое другое газообразное вещество, смешанное с R32, может спровоцировать чрезмерное давление, которое может привести к поломке или разрыву труб и травмированию людей.**

**Для ремонта или технического обслуживания используйте медные трубки, соответствующие стандарту NF EN 12375-1 и Европейской директиве 97/23/ЕС, регулирующей использование оборудования под давлением.**

**Когда тепловой насос находится под давлением, не проделывайте отверстия в трубах и не пытайтесь их паять. Существует опасность взрыва.**

**Не подвергайте устройство воздействию огня, искр или других источников возгорания. Оно может взорваться, что, возможно, приведет к серьезным травмам или смерти.**

**Для обнаружения утечек хладагента не используйте галогенную лампу или любой другой детектор с открытым пламенем. Ни при каких обстоятельствах не используйте потенциальные источники воспламенения.**

Данное изделие содержит газ фреон, применение которого оговорено в Киотском протоколе. Не выпускайте эти газы в атмосферу.

Значение в рамках потенциала глобального потепления<sup>(1)</sup> : 675. Значение базируется на 4-м отчете Межправительственной группы экспертов по изменению климата (GIEC). Группа безопасности: A2L.

Количество хладагента в соответствии с регламентом F-Gas 517/2014 указано на заводской табличке устройства.

Любые работы с контуром хладагента должен выполнять квалифицированный специалист, как указано выше.

В рамках европейского или местного законодательства могут проводиться периодические проверки на предмет возможной утечки хладагента. Для получения дополнительной информации обратитесь к Вашему местному дистрибьютору.

- Внимание! Хладагенты могут не иметь запаха.
- Не прокалывайте и не нагревайте трубопровод, так как существует опасность взрыва и получения сильных ожогов.
- Не используйте никакие средства для ускорения процесса размораживания или очистки, кроме тех, которые рекомендованы производителем.
- Устройство следует хранить в помещении, в котором нет постоянно работающих источников воспламенения (например, открытого огня, работающих газовых приборов или электронагревателей).

(1) Возможность глобального потепления

## Условия установки

- Этот тепловой насос предназначен исключительно для нагрева воды в бассейне. Не используйте это оборудование для других целей.
- Не пытайтесь выполнить установку этого устройства самостоятельно.
- Если вы обнаружите какую-либо неисправность или аномальную ситуацию, не устанавливайте тепловой насос и немедленно свяжитесь с вашим дилером.
- Тепловой насос должен храниться в хорошо проветриваемом помещении с площадью пола более  $A_{\text{мин}}$  (м<sup>2</sup>), определяемой по следующей формуле:  
$$A_{\text{мин}} = (M / (2,5 \times 0,22759 \times h_0))^2,$$
где  $M$  — количество хладагента в устройстве в кг, а  $h_0$  — высота хранения. Для напольного хранения  $h_0 = 0,6$  м.
- Это изделие предназначено исключительно для бытового использования и установки вне помещений. Воздух, выходящий из изделия, должен проходить свободно и не должен использоваться для других целей, например для обогрева или охлаждения помещения или здания.
- Проверьте шнур питания. Если шнур питания поврежден, его следует заменить у производителя, в службе послепродажного обслуживания или у любого лица, имеющего соответствующую квалификацию.
- Устройство должно быть обязательно подключено к непрерывной цепи заземления. Длина заземляющего провода должна быть больше длины остальных проводов, чтобы предотвратить риск поражения электрическим током при отрывании шнура. Электроустановка должна быть оснащена дифференциальной защитой на 30 мА (см. § 3.4).
- Убедитесь в том, что размер подставки для устройства соответствует его весу.
- **Любое невыполнение рекомендаций аннулирует гарантию.**

## Инструкции по техническому обслуживанию

Для гарантирования продолжительной и надежной работы теплового насоса рекомендуется раз в год проводить следующие операции по обслуживанию устройства.

- Техническое обслуживание и необходимые процедуры должны осуществляться с частотой и в сроки, определенные в настоящем руководстве.
- Используйте только оригинальные запасные части.
- Проверьте шнур питания. Если шнур питания поврежден, его следует заменить у производителя, в службе послепродажного обслуживания или у любого лица, имеющего соответствующую квалификацию.
- Проверьте цепь заземления устройства и ее непрерывность.

- Очистите испаритель с помощью мягкой зубной щетки или воздушной/водяной струи. **Внимание: никогда не используйте для очистки высокое давление.**
- Проверьте, что конденсат хорошо стекает.
- Проверьте надежность гидротехнических и электрических соединений.
- Проверьте гидравлическую герметичность конденсатора.
- Проверку изоляции холодильной системы выполняет **уполномоченный специалист** с помощью детектора течи.



***Перед производством любых работ по техническому обслуживанию теплового насоса необходимо отсоединить его от источника питания. Все операции по техническому обслуживанию должны производиться только специально подготовленным персоналом, имеющим опыт работы с жидкими хладагентами.***

## **Инструкции по зимовке**

- Переведите тепловой насос в режим "ВЫКЛ."
- Отключите тепловой насос от источника питания.
- Слейте содержимое конденсатора для предотвращения риска повреждения (риск возможного замерзания).
- Закройте "перепускной" вентиль и отсоедините штуцерные соединения входа/выхода.
- С помощью пистолета высокого давления максимально выдуйте остатки воды из конденсатора.
- Перекройте вход и выход для воды теплового насоса для предотвращения попадания туда инородных тел.
- Укройте тепловой насос предназначенным для этих целей зимним чехлом.



***Любые неполадки, вызванные неправильной консервацией на зимний период, аннулируют гарантию.***

## **Условия установки**

Детям от 8 лет, лицам с физическими и умственными расстройствами, а также с нарушениями чувствительности, или с отсутствием опыта и знаний, разрешается пользоваться устройством под присмотром, или если они получили инструкции по эксплуатации устройства и приняли к сведению сопутствующие риски. Не позволяйте детям играть с устройством.

Очистка и обслуживание устройства не должны выполняться детьми без присмотра.



## 2. ТЕХНИЧЕСКИЕ ХАРАКТЕРИСТИКИ

### 2.1 Технические данные теплового насоса

Модели	FULL INVERTER	HP5091DT3HA	HP5111DT3HA	HP5151DT3HA	HP5181DT3HA
Напряжение питания	B	220–240 В ~/1 ph/50 Гц			
Хладагент	/	R32			
Количество	кг	0,430	0,450	0,60	0,670
Масса в tCO <sub>2</sub> eq	/	0,29	0,30	0,41	0,45
Частота проверок на наличие утечек	/	Требования отсутствуют, но рекомендуется ежегодно			
Нагревательная способность мин. – макс. <sup>(a)</sup>	кВт	2,46 – 9,17	2,36 – 11,45	3,31 – 15,90	3,2 – 18,15
Поглощаемая электрическая мощность мин. – макс. <sup>(a)</sup>	кВт	0,17 – 1,45	0,17 – 1,80	0,27 – 2,84	0,22 – 3,13
Номинальный эксплуатационный ток мин. – макс. <sup>(a)</sup>	A	1,17 – 6,42	1,19 – 7,85	1,37 – 12,35	1,45 – 13,58
КПД мин. – макс. <sup>(a)</sup>	/	14,37 – 6,32	13,88 – 6,35	12,26 – 5,59	14,34 – 5,80
Нагревательная способность мин. – макс. <sup>(b)</sup>	кВт	1,75 – 7,05	1,56 – 8,00	3,05 – 12,40	2,86 – 14,11
Поглощаемая электрическая мощность мин. – макс. <sup>(b)</sup>	кВт	0,27 – 1,51	0,279 – 1,74	0,42 – 2,65	0,43 – 2,99
КПД мин. – макс. <sup>(b)</sup>	/	6,40 – 4,65	5,60 – 4,80	7,26 – 4,68	6,63 – 4,71
Максимальный эксплуатационный ток (МЭТ)	A	8,40	9,50	14	15,9
Номинал плавкого предохранителя	aM	10	12	16	20
Изогнутый предохранитель D	D	10	12	16	20
Пусковой ток	A	< МЭТ			
Гидравлическое соединение	мм	50 мм			
Номинальный расход воды <sup>(a)</sup>	м³/ч	4,00	5,00	6,70	7,70
Максимальная потеря напора воды	кПа	3,80	4,0	6,3	10
Компрессор	/	DC Inverter Panasonic		DC Inverter Mitsubishi	
Тип	/	Двойной ротационный		Двойной ротационный	
Количество	/	1			
Сопrotивление обмотки при температуре 20 °C	Ом	1,208		0,95	
Вентилятор	/	осевой			
Количество		1			
Диаметр	мм	405		510	
Количество лопастей	/	3			
Двигатель	/	DC Inverter			
Количество	/	1			
Скорость вращения	об/мин	400 – 700	500 – 850	300 – 750	400 – 750
Скорость в бесшумном режиме	об/мин	400	500	300	400
Уровень акустического давления на 1 м	дБ(A)	50,2	53,9	50,8	54,0
Уровень акустического давления на 10 м	дБ(A)	32,8	34,2	33,8	37,25
Чистые размеры устройства (Д-Ш-В)	мм	1003 / 418 / 605		1048 / 437 / 768	1161 / 473 / 862
Масса	кг	44	45	66	70

(a) Сухой воздух 27 °C — относительная влажность 78 % — температура воды на входе 26 °C.



(b) Сухой воздух 15 °C — относительная влажность 71 % — температура воды на входе 26 °C.

## 2. ТЕХНИЧЕСКИЕ ХАРАКТЕРИСТИКИ (продолжение)

---

### 2.2 Рабочий диапазон

Для обеспечения надежной и эффективной работы теплового насоса используйте его в следующих рабочих диапазонах температур и влажности.

	Режим подогрева 	Режим Охлаждение 
Температура окружающей среды	-7°C – +35°C	+7°C – +43°C
Температура воды	+12°C – +32°C	+8°C – +40°C
Относительная влажность	< 80%	< 80%
Рабочий диапазон заданного значения	+15°C – +32°C	+8°C – +32°C



**Если температура или влажность не соответствуют указанным условиям, может сработать защитное устройство, и тогда тепловой насос может отключиться.**



**Максимальная температура нагрева ограничена до 32°C во избежание повреждения покрытия. Фирма Nuward не несет ответственности в случае эксплуатации при температуре выше 32°C.**

## 2. ТЕХНИЧЕСКИЕ ХАРАКТЕРИСТИКИ (продолжение)

### 2.3 Размеры

Модели :

HP5091DT3HA / HP5111DT3HA / HP5151DT3HA / HP5181DT3HA

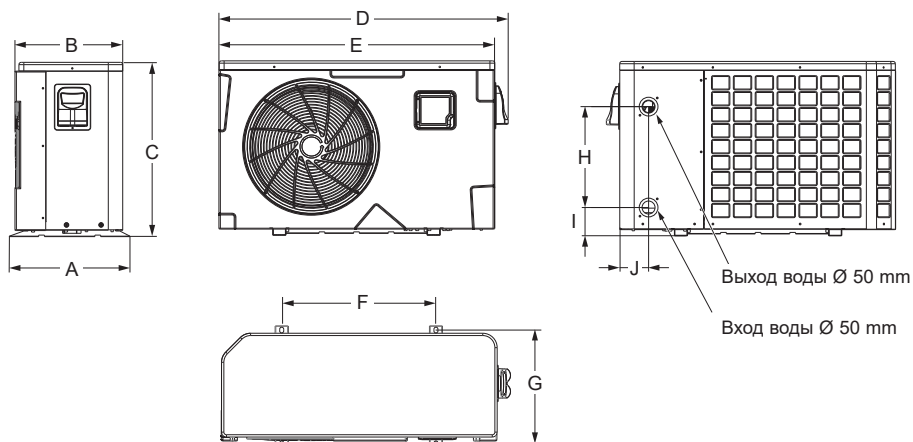

Устройство : mm

Позиция \ Модель	HP5091DT3HA / HP5111DT3HA	HP5151DT3HA	HP5181DT3HA
<b>A</b>	418	436,5	473
<b>B</b>	374	418	451,5
<b>C</b>	604,5	767,5	862
<b>D</b>	1003	1047,5	1160,5
<b>E</b>	956	1002	1115
<b>F</b>	535	615	790
<b>G</b>	394,5	410	447
<b>H</b>	350	350	466
<b>I</b>	97,7	101,2	97,6
<b>J</b>	99,2	106,5	113,5

## 3. УСТАНОВКА И ПОДКЛЮЧЕНИЕ

### 3.1 Принципиальная Схема

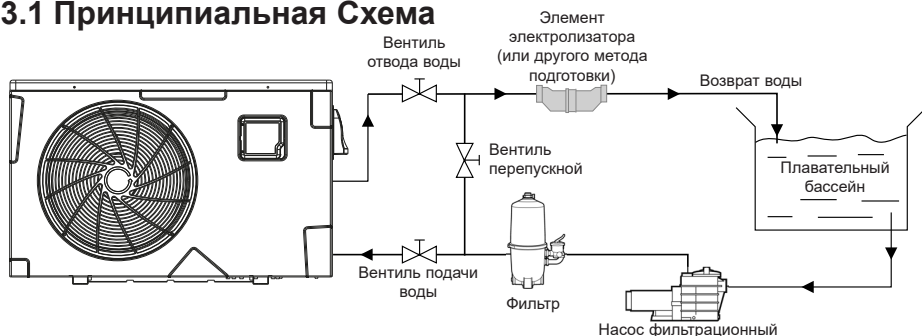

Примечание : Тепловой насос поставляется без какого-либо дополнительного оборудования для подготовки или фильтрации воды. Представленные на схеме элементы поставляются фирмой, осуществляющей установку.

### 3.2 Тепловой насос



**Разместите тепловой насос на открытом воздухе, отдельно от любого другого закрытого оборудования.**

**Выберите место предпочтительно с доступом солнечного света и защищенное от сильного ветра.**

**Устройство должно находиться в легко доступном месте для последующего монтажа и технического обслуживания.**

**Разместите его под навесом, с соблюдением всех указанных минимальных расстояний до других предметов, чтобы избежать всех рисков, связанных с рециркуляцией воздуха и возможного отрицательного влияния теплового насоса на состояние окружающей среды.**

Устройство : мм

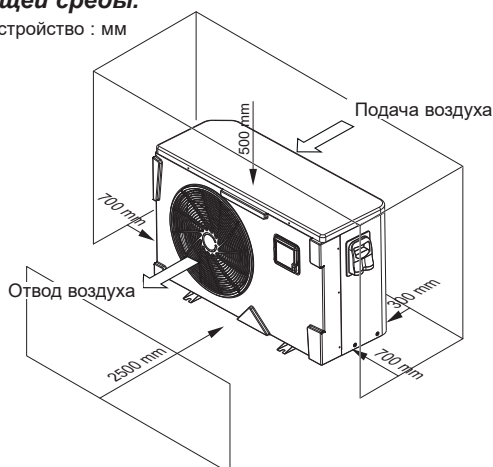

### 3. УСТАНОВКА И ПОДКЛЮЧЕНИЕ (продолжение)



*Не устанавливайте устройство непосредственно на пол, так как это может привести к проблемам.*

*Для установки устройства на пол предпочтительно использовать антивибрационные подкладки.*

*Не следует использовать настенный кронштейн в условиях, где могут передаваться вибрации.*

*Не устанавливайте тепловой насос на подставку, которая может усилить вибрацию устройства.*

*Не устанавливайте тепловой насос в месте, которое может повышать уровень шума, или где шум от устройства может помешать соседям.*

*Не используйте адгезивы, так как они не могут обеспечить надежное крепление.*

*Предпочтительно устанавливать тепловой насос на плоской, не связанной бетонной плите. Установите тепловой насос на прилагаемые сайлент-блоки (прилагаются винты и шайбы).*

*Во избежание несчастного случая или повреждения оборудования и травмирования людей закрепите устройство, используя указанный момент затяжки.*

*Как вариант, тепловой насос можно установить на резиновые крепления к полу с помощью подходящих винтов (не входят в комплект поставки).*

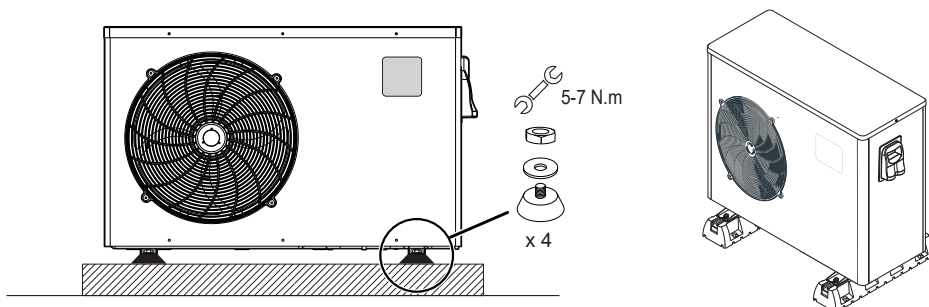

*Максимальное расстояние между тепловым насосом и плавательным бассейном не должно превышать 15 м.*

*Общая длина шлангов подачи и отвода воды не должна превышать 30 м.*

*Изолировать шланги от поверхности земли и не закапывать.*

*Тепловой насос должен быть установлен на минимальном расстоянии от бассейна в соответствии с NF C 15-100 (либо в 3,5 м от водной поверхности во Франции) или в соответствии со стандартами установки в других странах.*

*Не устанавливать тепловой насос вблизи источников тепла.*

*При установке в снежных регионах, рекомендуется устанавливать изделие в помещении, чтобы избежать накопления снега на испарителе.*

## 3. УСТАНОВКА И ПОДКЛЮЧЕНИЕ (продолжение)

### 3.3 Гидротехническое подключение

Тепловой насос поставляется с двумя штуцерными соединениями диаметром 50 мм с накидной гайкой. Для подвода воды используйте ПВХ шланги Ø 50 мм. Соедините входное отверстие для воды теплового насоса со шлангом, ведущим к фильтрационному блоку, затем соедините выходное отверстие для воды теплового насоса со шлангом, подающим воду в бассейн (см. приведенную ниже схему).

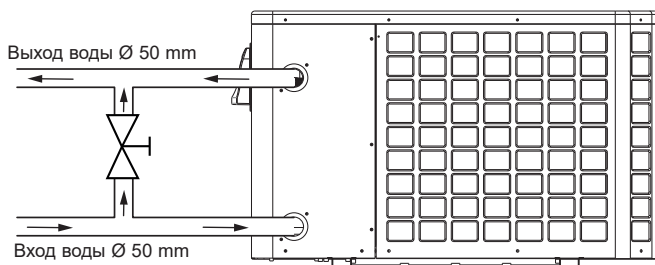

Установите так называемый "перепускной" вентиль между входным и выходным отверстиями теплового насоса.



**Если используются автоматическое питательное устройство или электризатор, они должны быть установлены непосредственно после теплового насоса с целью предохранения конденсатора *Titape* от чрезмерного накопления в нем химических продуктов.**



**Постарайтесь установить перепускной вентиль и поставляемые штуцерные соединения на одном уровне с входом и выходом воды на устройстве, чтобы упростить спуск воды на зимний период, облегчив таким образом доступ к элементам и демонтаж на период технического обслуживания.**

### 3. УСТАНОВКА И ПОДКЛЮЧЕНИЕ (продолжение)

#### 3.4 Электрическое Подключение



**Электроподключение и все соединения данного оборудования должны соответствовать местным действующим правилам установки.**

Франция	NF C15-100	Великобритания	BS7671:1992
Дания	DIN VDE 0100-702	Англия и Уэльс	EVHS-HD 384-7-702
А	ÖVE 8001-4-702	Венгрия	MSZ 2364-702/1994/MSZ 10-553 1/1990
Испания	UNE 20460-7-702 1993, RECBT ITC-BT-31 2002	Мэн	MSA HD 384-7-702.S2
Ирландия	Монтажные правила + IS HD 384-7-702	Польша	PN-IEC 60364-7-702:1999
Италия	CEI 64-8/7	Чехия	CSN 33 2000 7-702
Люксембург	384-7.702 S2	Словакия	STN 33 2000-7-702
Нидерланды	NEN 1010-7-702	Словения	SIST HD 384-7-702.S2
Португалия	RSIUUE	Турция	TS IEC 60364-7-702



**Убедитесь, что имеющееся в наличии электропитание и частота соответствуют требуемым параметрам тока, приняв во внимание специфическую установку прибора и потребности всех других устройств, подключенных к данной цепи.**

**HP5091DT3HA / HP5111DT3HA / HP5151DT3HA / HP5181DT3HA  
230V ~ +/- 10 % 50 Hz 1 Фаза**

**Соблюдайте требования соответствующей схемы соединений в приложении.**

**Соединительная коробка находится с правой стороны устройства. Три контактных соединения предназначены для подключения электропитания, два других - для подключения механизма управления фильтрационного насоса (Системы автоматического управления).**

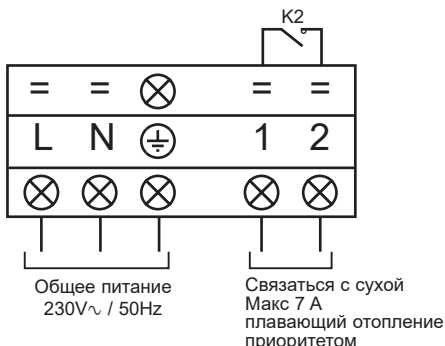

### 3. УСТАНОВКА И ПОДКЛЮЧЕНИЕ (продолжение)



**Запрещено использовать розетку для подачи питания. Линия электропитания должна быть оснащена соответствующим многополюсным устройством защиты типа изогнутого предохранителя D, а также автоматическим выключателем дифференциальной защиты на 30 мА. (см. следующую таблицу).**

Модели		HP5091DT3HA	HP5111DT3HA	HP5151DT3HA	HP5181DT3HA
Электропитание	В/Фаза/ Гц	230V~ 50Hz	230V~ 50Hz	230V~ 50Hz	230V~ 50Hz
Автоматический выключатель, кривая D	A	8 D	10 D	16 D	20 D
Сечение кабеля	MM <sup>2</sup>	3G 2,5	3G 2,5	3G 2,5	3G 4



**Используйте кабель питания типа RO 2V / R 2V или аналогичный.**



**Сечения кабеля даны из расчета максимальной длины - 25 м. Тем не менее, необходимо их проверять и адаптировать согласно условиям установки.**



**Перед открытием блока электроуправления всегда отключайте источник основного питания. После отключения питания подождите 10 минут, прежде чем начинать работу со внутренними активными элементами оборудования (в конденсаторах сохраняется энергия).**

#### 3.5 Первый запуск

Процедура запуска - после того, как закончена установка, неуклонно следуйте следующему порядку действий :

- 1) Проверните вентиляторы рукой для проверки их свободного вращения и соответствия крепления винта на валу мотора.
- 2) Убедитесь в том, что устройство правильно подключено к источнику основного питания (см. схему соединения в приложении).
- 3) Включите фильтрационный насос.
- 4) Перед тем как перейти к режимам подогрева или охлаждения, проверьте, чтобы все вентили были открыты и чтобы вода поступала в устройство.
- 5) Проверьте, чтобы трубка оттока конденсата была правильно установлена, чтобы не создавалось никаких помех.
- 6) Включите электропитание устройства, затем нажмите кнопку Пуск/ Стоп  на панели управления.



### 3. УСТАНОВКА И ПОДКЛЮЧЕНИЕ (продолжение)

---

- 7) Убедитесь в том, что символы тревоги или блокировки не отображаются. При необходимости см. руководство по устранению неисправностей (см. § 6.4).
- 8) Установите пропускную способность для воды с помощью перепускного вентиля (см. § 3.6 и 2.1) на уровне, предусмотренном для соответствующей модели, так, чтобы разница температур воды на входе/выходе составляла 2°C.
- 9) После нескольких минут работы проверьте, чтобы температура воздуха, выходящего из устройства, понизилась (была между 5 и 10°).
- 10) Не выключая устройства, остановите фильтрационный насос. Устройство должно автоматически отключиться и показать код ошибки E03.
- 11) Оставьте устройство и насос плавательного бассейна включенными круглосуточно, пока температура воды не достигнет желаемого уровня. Когда температура воды на входе достигнет заданного значения, устройство отключится. Оно снова самостоятельно включится (при условии, что будет включен насос плавательного бассейна), если температура в плавательном бассейне понизится хотя бы на 0.5°C от заданной.

**Контроллер пропускной способности** - Устройство снабжено контроллером пропускной способности, который включает тепловой насос при включенном фильтрационном насосе плавательного бассейна, и отключает тепловой насос при неработающем фильтрационном насосе. При отсутствии поступления воды на экране регулятора загорится код ошибки E03 (См. § 6.4).

**Задержка** - устройство работает с задержкой в 3 минуты с целью защиты компонентов управляющей цепи, устранения любой нестабильности при повторном запуске и всех помех в цепи контактора. Благодаря данной задержке устройство автоматически включается примерно через 3 минуты после полного отключения управляющей цепи. Таким же образом кратковременное отключение тока активизирует цепь задержки включения.

## 3. УСТАНОВКА И ПОДКЛЮЧЕНИЕ (продолжение)

### 3.6 Установка пропускной способности насоса

Открыв вентили входа и выхода воды, отрегулируйте так называемый "перепускной" вентиль так, чтобы разница между температурами воды на входе и выходе составляла 2°C (см. § 3.1 принципиальной схемы). Вы можете проверить правильность регулировки, контролируя отображаемые на командной панели значения температур воды на входе и выходе.



Температура воды на входе

Температура воды на выходе

Примечание : Открытие так называемого "перепускного" вентиля понижает влияние пропускной способности на повышение разницы температур  $\Delta T$ .  
Закрытие так называемого "перепускного" вентиля повышает влияние пропускной способности на понижение разницы температур  $\Delta T$ .

## 4. ИНТЕРФЕЙС ПОЛЬЗОВАТЕЛЯ

### 4.1 Общие сведения

Тепловой насос оборудован панелью цифрового управления с тактильным экраном, соединенной электрически с устройством и настроенным на заводе на режим подогрева.

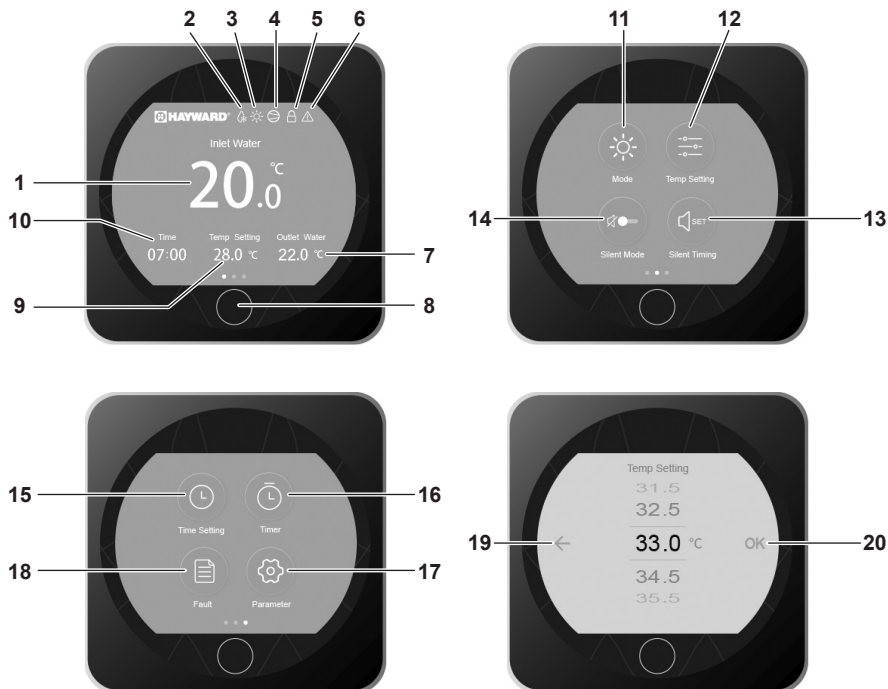

### Условные обозначения

1	воды на входе
2	Режим оттаивания
3	Режим работы
4	Индикатор работы компрессора
5	Блокировка экрана
6	Тревога
7	Температура воды на выходе
8	Вкл./выкл./возврат
9	Заданная температура
10	время

11	Выбор режима работы
12	Установка заданного значения
13	Настройка таймера режима тишины
14	Включение бесшумного режима
15	Настройка даты и времени
16	Настройка таймеры включения и выключения
17	Доступ к расширенным настройкам
18	Доступ к списку неисправностей
19	Возврат (без проверки)
20	Подтверждение

## 4. ИНТЕРФЕЙС ПОЛЬЗОВАТЕЛЯ (продолжение)

### Режим ВЫКЛ. (ВЫКЛЮЧЕНИЕ)

Когда тепловой насос выключен (находится в режиме ожидания), на экране отображается слово ВЫКЛ. Черный экран означает, что тепловой насос выключен. В этом режиме можно настраивать параметры.



### Режим ВКЛ. (ВКЛЮЧЕНИЕ)

Когда тепловой насос работает или настраивается (достигает заданного значения), экран становится синим.



Для перехода из режима ВЫКЛ. в режим ВКЛ. и наоборот нажмите кнопку .

## 4. ИНТЕРФЕЙС ПОЛЬЗОВАТЕЛЯ (продолжение)

### 4.2 Настройка даты и времени

Установка даты и времени может быть выполнена в режиме ВКЛ. или ВЫКЛ.

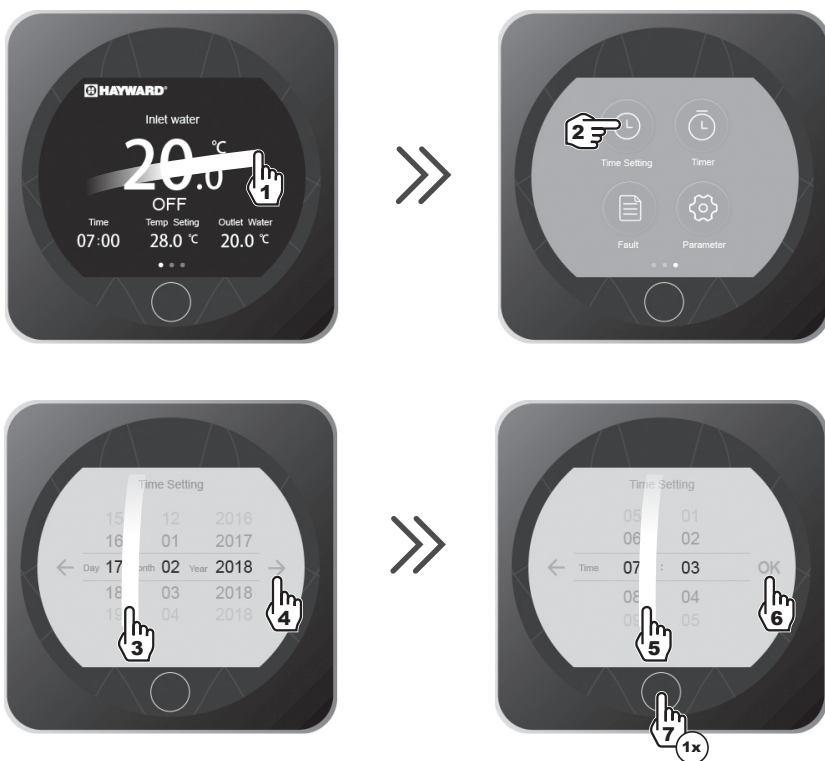

- Нажмите ● 1 раз, чтобы вернуться на главный экран.

## 4. ИНТЕРФЕЙС ПОЛЬЗОВАТЕЛЯ (продолжение)

### 4.3 Установка таймеров включения и выключения.

Установка этой функции нужна в том случае, если Вы хотите, чтобы тепловой насос работал в течение более короткого периода времени по сравнению с установленным временем фильтрации. Вы также можете запрограммировать произвольное время включения и выключения или просто отключить временной рабочий диапазон (например, ночью).

Вы можете запрограммировать таймер Пуск и Timer Off.

Шаг настройки — «почасовой».



## 4. ИНТЕРФЕЙС ПОЛЬЗОВАТЕЛЯ (продолжение)



*Сверхъяркий синий = Активировано*  
*Серый = Деактивировано*

- Нажмите  2 раз, чтобы вернуться на главный экран.

## 4. ИНТЕРФЕЙС ПОЛЬЗОВАТЕЛЯ (продолжение)

### 4.4 Установка заданного значения

Заданное значение устанавливается как в режиме ВКЛ., так и в режиме ВЫКЛ. с точностью до 0,5 °С.



- Нажмите  1 раз, чтобы вернуться на главный экран.



**Чтобы избежать деформации жаровых трубок, рекомендуется никогда не превышать температуру 30°C.**



## 4. ИНТЕРФЕЙС ПОЛЬЗОВАТЕЛЯ (продолжение)

### 4.5 Блокировка и разблокировка тактильного экрана

Блокировка и разблокировка экрана может выполняться в режиме ВКЛ. или ВЫКЛ.



Заблокировано



Разблокировано

## 4. ИНТЕРФЕЙС ПОЛЬЗОВАТЕЛЯ (продолжение)

### 4.6 Настройка функции бесшумного режима SILENCE

Режим тишины позволяет использовать тепловую помпу в экономном режиме и тишине в случае низкой нагревательной потребности (поддерживать температуру в бассейне или, если нужно, поддерживать тихий режим работы).

Эта функция может быть активирована/деактивирована вручную или с помощью таймера..

#### Активация/деактивация



Бесшумный выключен



Режим тишины активирован



- Нажмите  1 раз, чтобы вернуться на главный экран.

## 4. ИНТЕРФЕЙС ПОЛЬЗОВАТЕЛЯ (продолжение)

### Настройка таймера БЕСШУМНОГО режима



## 4. ИНТЕРФЕЙС ПОЛЬЗОВАТЕЛЯ (продолжение)



- Нажмите  2 раз, чтобы вернуться на главный экран.



**Шаг настройки — «почасовой».**

**После активации Таймер действует круглосуточно 7 дней в неделю.**

## 5. ТЕХНИЧЕСКОЕ ОБСЛУЖИВАНИЕ - ЗИМОВКА

### 5.1 Техническое обслуживание

Для гарантирования продолжительной и надежной работы теплового насоса рекомендуется раз в год проводить следующие операции по обслуживанию устройства.

- Обслуживание и ремонт устройства должны выполняться квалифицированным специалистом в соответствии с нормативными документами и отраслевыми стандартами, действующими в стране, в которой устройство будет устанавливаться (см. § 3.4). Любые работы с холодильным контуром должен выполнять специалист, имеющий сертификат, подтверждающий право работы с хладагентами.
- Проверьте шнур питания. Если шнур питания поврежден, его следует заменить у производителя, в службе послепродажного обслуживания или у любого лица, имеющего соответствующую квалификацию.
- Проверьте цепь заземления устройства и ее непрерывность.
- Очистите испаритель с помощью мягкой зубной щетки или воздушной/водяной струи. **Внимание: никогда не используйте для очистки высокое давление.**
- Проверьте, что конденсат хорошо стекает.
- Проверьте надежность гидротехнических и электрических соединений.
- Проверьте гидравлическую герметичность конденсатора.
- Проверку изоляции холодильной системы выполняет уполномоченный специалист с помощью детектора течи.



*Перед производством любых работ по техническому обслуживанию теплового насоса необходимо отсоединить его от источника питания. Все операции по техническому обслуживанию должны производиться только специально подготовленным персоналом, имеющим опыт работы с жидкими хладагентами.*

## **5. ТЕХНИЧЕСКОЕ ОБСЛУЖИВАНИЕ (продолжение)**

### **5.2 Консервация на зиму**

- Переведите тепловой насос в режим "ВЫКЛ."
- Отключите тепловой насос от источника питания.
- Слейте содержимое конденсатора для предотвращения риска повреждения (риск возможного замерзания).
- Закройте "перепускной" вентиль и отсоедините штуцерные соединения входа/выхода.
- С помощью пистолета высокого давления максимально выдуйте остатки воды из конденсатора.
- Перекройте вход и выход для воды теплового насоса для предотвращения попадания туда инородных тел.
- Укройте тепловой насос предназначенным для этих целей зимним чехлом.



***Любые неполадки, вызванные неправильной консервацией на зимний период, аннулируют гарантию.***

# 6. ПРИЛОЖЕНИЯ

## 6.1 Электрические схемы

### HP5091DT3HA / HP5111DT3HA

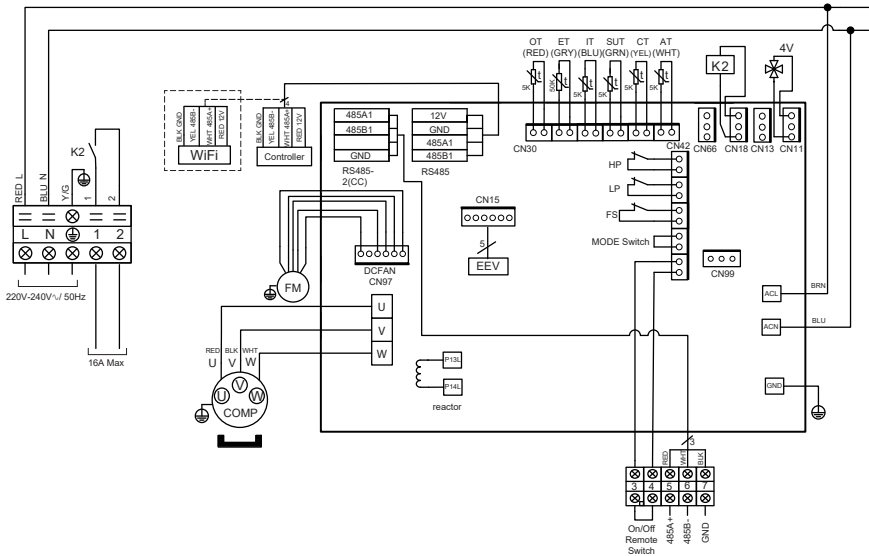

#### ПРИМЕЧАНИЯ

- |  |   |
|--|---|
| <b>AT</b> : ДАТЧИК ТЕМПЕРАТУРЫ ВОЗДУХА       | <b>LP</b> : ПРЕССОСТАТ НИЗКОГО ДАВЛЕНИЯ       |
| <b>COMP</b> : КОМПРЕССОР                     | <b>OT</b> : ДАТЧИК ТЕМПЕРАТУРЫ ВОДЫ НА ВЫХОДЕ |
| <b>CT</b> : ДАТЧИК ТЕМПЕРАТУРЫ ИСПАРИТЕЛЯ    | <b>SUT</b> : ДАТЧИК ТЕМПЕРАТУРЫ ВСАСЫВАНИЯ    |
| <b>EEV</b> : ЭЛЕКТРОННЫЙ РЕДУКТОР            | <b>4V</b> : 4-Х КАНАЛЬНЫЙ ВЕНТИЛЬ             |
| <b>FM</b> : МОТОР ВЕНТИЛЯТОРА                | <b>K2</b> : МАКСИМАЛЬНЫМ ПОТЕНЦИАЛОМ 16 А     |
| <b>FS</b> : ДЕТЕКТОР НАЛИЧИЯ ВОДЫ            | <b>ET</b> : ДАТЧИК ТЕМПЕРАТУРЫ НАГНЕТАНИЯ     |
| <b>HP</b> : ПРЕССОСТАТ ВЫСОКОГО ДАВЛЕНИЯ     | <b>---</b> : ДОПОЛНИТЕЛЬНО                    |
| <b>IT</b> : ДАТЧИК ТЕМПЕРАТУРЫ ВОДЫ НА ВХОДЕ |   |

## 6. ПРИЛОЖЕНИЯ (продолжение)

### HP5151DT3HA / HP5181DT3HA

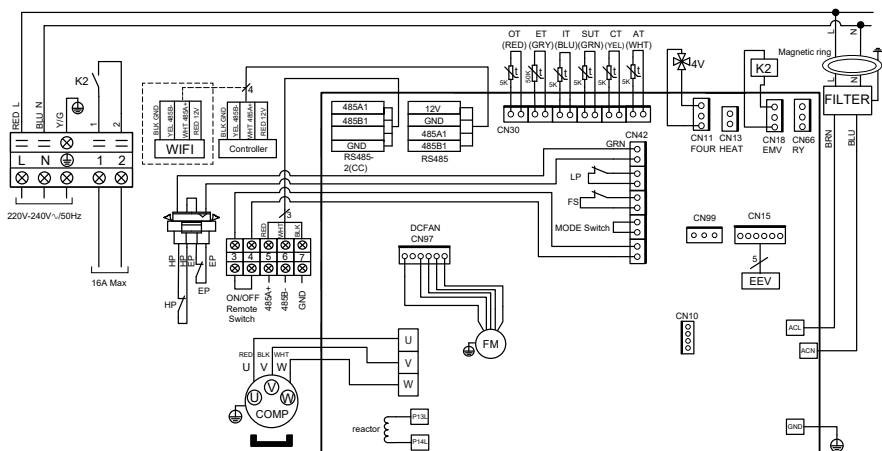

#### ПРИМЕЧАНИЯ

- |  |   |
|--|---|
| <b>AT</b> : ДАТЧИК ТЕМПЕРАТУРЫ ВОЗДУХА       | <b>LP</b> : ПРЕССОСТАТ НИЗКОГО ДАВЛЕНИЯ               |
| <b>COMP</b> : КОМПРЕССОР                     | <b>OT</b> : ДАТЧИК ТЕМПЕРАТУРЫ ВОДЫ НА ВЫХОДЕ         |
| <b>CT</b> : ДАТЧИК ТЕМПЕРАТУРЫ ИСПАРИТЕЛЯ    | <b>SUT</b> : ДАТЧИК ТЕМПЕРАТУРЫ ВСАСЫВАНИЯ            |
| <b>EEV</b> : ЭЛЕКТРОННЫЙ РЕДУКТОР            | <b>4V</b> : 4-Х КАНАЛЬНЫЙ ВЕНТИЛЬ СВОБОДНЫМ КОНТАКТ С |
| <b>FM</b> : МОТОР ВЕНТИЛЯТОРА                | <b>K2</b> : МАКСИМАЛЬНЫМ ПОТЕНЦИАЛОМ 16 А             |
| <b>FS</b> : ДЕТЕКТОР НАЛИЧИЯ ВОДЫ            | <b>ET</b> : ДАТЧИК ТЕМПЕРАТУРЫ НАГНЕТАНИЯ             |
| <b>HP</b> : ПРЕССОСТАТ ВЫСОКОГО ДАВЛЕНИЯ     | <b>-----</b> : ДОПОЛНИТЕЛЬНО                          |
| <b>IT</b> : ДАТЧИК ТЕМПЕРАТУРЫ ВОДЫ НА ВХОДЕ |   |



## 6. ПРИЛОЖЕНИЯ (продолжение)

### 6.2 Включение подогрева в качестве приоритета

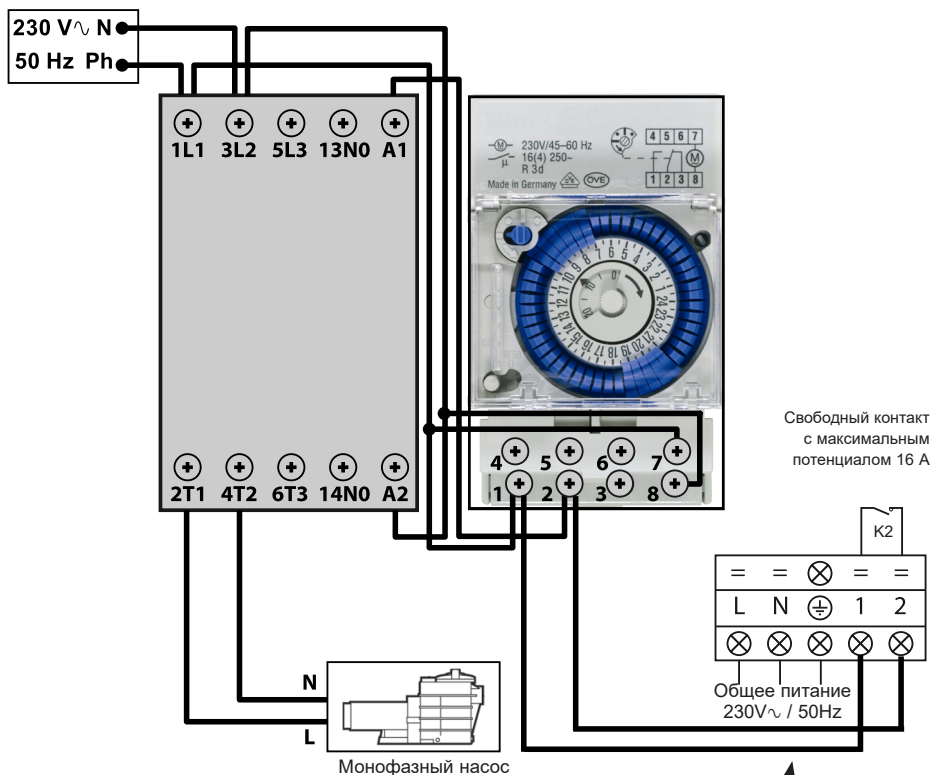

Разъемы 1 и 2 обеспечивают подачу питания на бесполярный контакт при напряжении 230V~/50Hz. Подключите кабели к разъемам 1 и 2 в соответствии с указанной монтажной схемой для автоматической регулировки насоса фильтрации по циклам в 2 минуты каждый час, когда температура резервуара снижается ниже установленного значения.

**!** Никогда не подключать питание фильтрационного насоса прямо к клеммам 1 и 2.



## 6. ПРИЛОЖЕНИЯ (продолжение)

### 6.3 Вид в разборе и съемные элементы

HP5091DT3HA / HP5111DT3HA / HP5151DT3HA / HP5181DT3HA

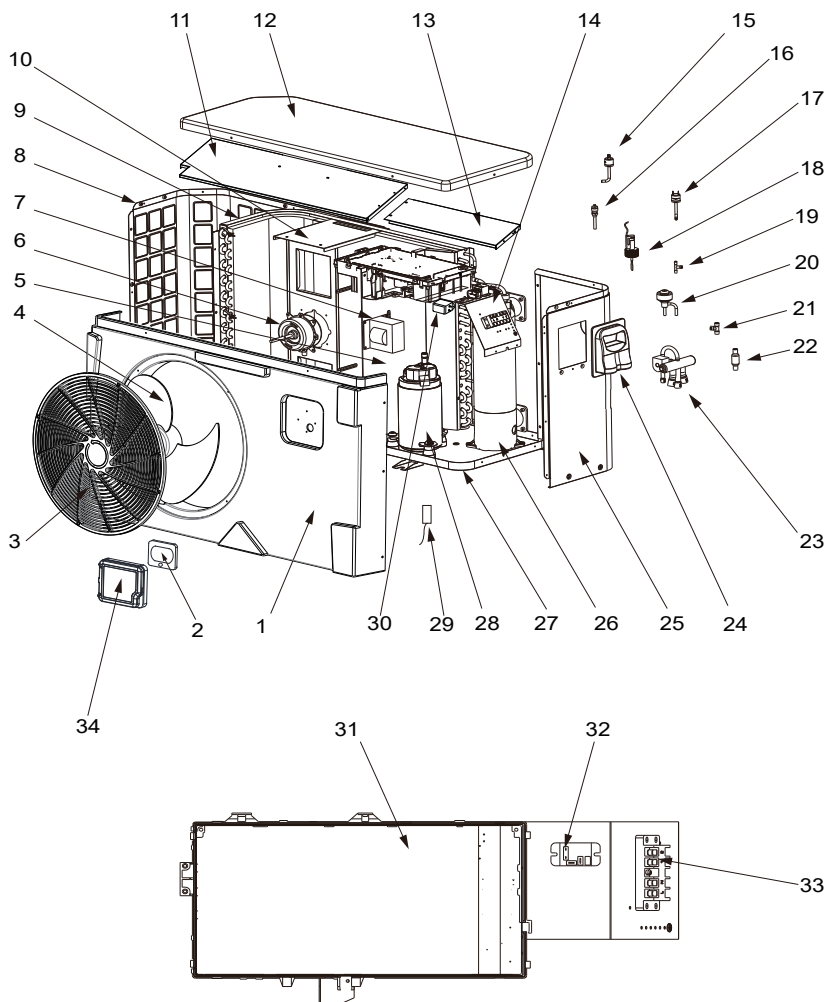

## 6. ПРИЛОЖЕНИЯ (продолжение)

Индикатор	Название	Справочный номер	HP5091DT3НА	HP5111DT3НА	HP5151DT3НА	HP5181DT3НА
1	Панель передняя	HWX80900843	✓	✓	нет данных	нет данных
		HWX80900844	нет данных	нет данных	✓	нет данных
		HWX80900850	нет данных	нет данных	нет данных	✓
2	LED контроллер	HWX72200070	✓	✓	✓	✓
3	Защитная сетка вентилятора	HWX80900375	✓	✓	✓	нет данных
		HWX20000220369	нет данных	нет данных	нет данных	✓
4	Винт вентилятора	HWX301030000006	✓	✓	нет данных	нет данных
		HWX301030000001	нет данных	нет данных	✓	✓
5	/	/	/	/	/	/
6	Мотор вентилятора DC	HWX80200018	✓	✓	нет данных	нет данных
		HWX20000330132	нет данных	нет данных	✓	✓
7	Катушка 16 A 50 Hz 5 мН Катушка 20 A 50 Hz 5.2 мН	HWX82500020	✓	✓	нет данных	нет данных
		HWX82500021	нет данных	нет данных	✓	✓
8	Левая панель	HWX80702123	✓	✓	нет данных	нет данных
		HWX80700244	нет данных	нет данных	✓	нет данных
		HWX80702268	нет данных	нет данных	нет данных	✓
9	Пластиночатый испаритель	HWX80600042	✓	нет данных	нет данных	нет данных
		HWX80600043	нет данных	✓	нет данных	нет данных
		HWX80600044	нет данных	нет данных	✓	нет данных
		HWX80600078	нет данных	нет данных	нет данных	✓
10	Опора двигателя	HWX80700218	✓	✓	нет данных	нет данных
		HWX80700248	нет данных	нет данных	✓	нет данных
		HWX80700329	нет данных	нет данных	нет данных	✓
11	/	/	/	/	/	/
12	Верхняя панель	HWX80900055	✓	✓	нет данных	нет данных
		HWX301090200806	нет данных	нет данных	✓	нет данных
		HWX80900076	нет данных	нет данных	нет данных	✓
13	/	/	/	/	/	/
14	/	/	/	/	/	/
15	Реле низкого давления NO 0.30 МПа / 0.15 МПа	HWX20000360157	✓	✓	✓	✓
16	Замер давления 40 мм 1/2 дюйма	HWX20000140150	✓	✓	✓	✓
17	Реле низкого давления NC 3.2 МПа/4.4 МПа	HWX20013605	✓	✓	✓	✓
18	Детектор пропускной способности	HWX83000068	✓	✓	✓	✓
19	Соединитель Т Ø 6.5-2 x Ø 6.5(Т) x 0.75	HWX20001460	✓	✓	✓	✓
20	Электронный редуктор	HWX81000011	✓	✓	нет данных	нет данных
		HWX81000013	нет данных	нет данных	✓	✓
21	Соединитель Т Ø 9.52-2 x Ø 6.35(Т) x 1.0	HWX304030000002	✓	✓	✓	✓
22	Фильтр Ø 9.7-Ø 9.7 (Ø19) Фильтр Ø 9.7-Ø 9.7 (Ø28)	HWX20000140178	✓	✓	нет данных	нет данных
		HWX20041444	нет данных	нет данных	✓	✓
23	4-ходовой клапан	HWX20041437	нет данных	✓	✓	✓
24	Трапп автоматизированные	HWX320922029	✓	✓	✓	✓
		HWX80700580	✓	✓	нет данных	нет данных
25	Правая панель	HWX80700878	нет данных	нет данных	✓	нет данных
		HWX80700581	нет данных	нет данных	нет данных	✓
		HWX72300013	✓	нет данных	нет данных	нет данных
26	Конденсатор Titane/ПВХ	HWX72300014	нет данных	✓	нет данных	нет данных
		HWX72300010	нет данных	нет данных	✓	нет данных
		HWX72300024	нет данных	нет данных	нет данных	✓
27	/	/	/	/	/	/
28	Компрессор	HWX80100108	✓	✓	нет данных	нет данных
		HWX80100046	нет данных	нет данных	✓	✓

## 6. ПРИЛОЖЕНИЯ (продолжение)

HP5091DT3HA / HP5111DT3HA / HP5151DT3HA / HP5181DT3HA

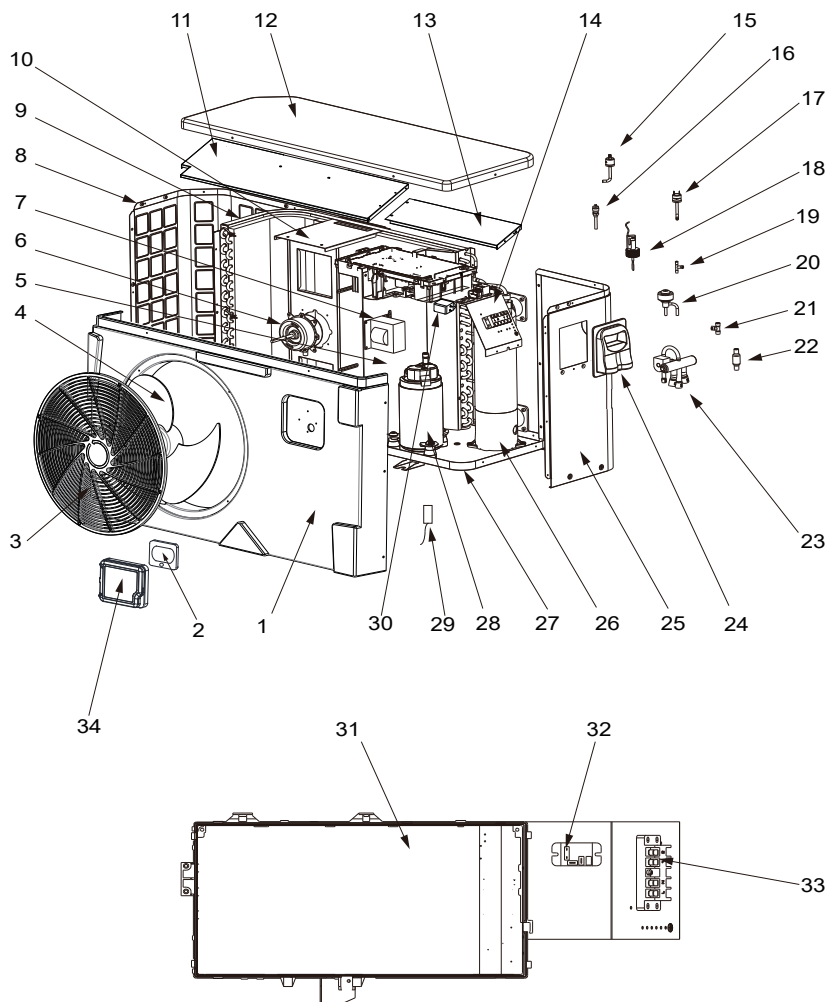

## 6. ПРИЛОЖЕНИЯ (продолжение)

Индикация	Название	Справочный номер	HP5091DT3HA	HP5111DT3HA	HP5151DT3HA	HP5181DT3HA
29	Датчик всасывания компрессора 5 к - 560 mm	HWX83000044	✓	✓	нет данных	нет данных
	Датчик всасывания компрессора 5 к - 760 mm	HWX83000053	нет данных	нет данных	✓	✓
	Датчик температуры воздуха 5 к - 350 mm	HWX83000049	✓	✓	✓	✓
	Воды на выходе зонда 5 к - 410 mm	HWX83000050	✓	✓	✓	✓
	Воды на входе зонда 5 к - 850 mm	HWX83000052	✓	✓	✓	нет данных
	Воды на входе зонда 5 к - 980 mm	HWX83000055	нет данных	нет данных	нет данных	✓
	датчик нагнетания компрессора 50 к - 660 mm	HWX83000026	✓	✓	✓	✓
	Датчик размораживания 5 к - 680 mm	HWX83000051	✓	✓	нет данных	нет данных
Датчик размораживания 5 к - 1040 mm	HWX83000045	✓	✓	✓	✓	
30	Фильтр EMC	HWX20003257	нет данных	нет данных	✓	✓
31	Управляющая электронная плата	HWX72200168AP3	✓	нет данных	нет данных	нет данных
		HWX72200168AP4	нет данных	✓	нет данных	нет данных
		HWX72200167AP5	нет данных	нет данных	✓	нет данных
		HWX72200167AP6	нет данных	нет данных	нет данных	✓
32	Реле K2	HWX20000360297	✓	✓	✓	✓
33	Переходник, L-N-GND 5-х контактный 4 mm <sup>2</sup>	HWX40003901	✓	✓	✓	✓
34	защитная дверь	HWX80900321	✓	✓	✓	✓

## 6. ПРИЛОЖЕНИЯ (продолжение)

### 6.4 Справочник по устранению неисправностей





*Некоторые операции должны выполняться квалифицированными специалистами.*

В случае неисправности теплового насоса в левом верхнем углу экрана отображается символ .

В случае неисправности следующие индикаторы появятся на экране:



*После решения проблемы ошибка автоматически отмечается как исправленная, и треугольник исчезает.*

- Чтобы очистить список ошибок, нажмите на .
- РНажмите  2 раз, чтобы вернуться на главный экран.

## 6. ПРИЛОЖЕНИЯ (продолжение)

Неисправности	Коды ошибок	Описание	Устранение
Неисправность датчика воды на входе	P01	Датчик открыт или произошло короткое замыкание.	Проверьте соединение CN21/RES1 на плате и удлинитель или замените датчик.
Неисправность датчика воды на выходе	P02		Проверьте соединение N22/RES2 на плате и удлинитель или замените датчик.
Неисправность датчика оттаивания	P04		Проверьте соединение CN12/PH на плате и удлинитель или замените датчик.
Неисправность датчика температуры окружающей среды	P05		Проверьте соединение CN8/OPT на плате и удлинитель или замените датчик.
Отсутствие зонда всасывания компрессора	P07		Проверьте соединение CN7/OAT на плате и удлинитель или замените датчик.
Отсутствие зонда нагнетания компрессора	P081		Проверьте соединение CN9/OHT на плате и удлинитель или замените датчик.
Защита от высокого давления	E01	Датчик открыт или произошло короткое замыкание.	Проверьте соединение CN30/HP на карте или замените датчик
			Проверьте расход воды
			Проверьте датчик расхода воды
			Проверьте открытие вентилялей
			Проверьте перепускную систему
			Проверьте засорение испарителя
			Температура воды слишком высокая
			Проблема с конденсатом после обслуживания, опорожните и извлеките сухую холодильную систему
Защита от низкого давления	E02	Датчик открыт или произошло короткое замыкание.	Слишком большое количество жидкости в системе, удалите жидкость в емкости с жидкостьюю
			Проверьте соединение AI/DI03 на карте или замените датчик
			Значительная утечка охлаждающей жидкости, найдите течь с помощью детектора
			Низкое количество поступающего воздуха, проверьте скорость вращения вентилятора
Неисправность детектора пропускной способности	E03	Датчик открыт или произошло короткое замыкание.	Проверьте засорение испарителя, очистите его поверхность
			Проверьте соединение AI/DI02 на карте или замените датчик
			Нехватка воды, проверьте работу фильтрационной помпы
			Проверьте, открыты ли стопорные вентили
			Проверьте регулировку перепускной системы

## 6. ПРИЛОЖЕНИЯ (продолжение)

Неисправности	Коды ошибок	Описание	Устранение
Разница температур на входе/выходе > 13 °С	E06	Применяется только в режиме охлаждения	Нехватка воды, проверьте работу фильтрационной помпы
			Проверьте, открыты ли стопорные вентили
			Проверьте регулировку перепускной системы
Защита от замерзания Холодный режим	E07	Количество воды на выходе слишком мало.	Проверить пропускную способность или датчик температуры воды на выходе.
Сбои в передаче информации	E08	Нет соединения между электронной платой и пользовательским интерфейсом	Проверьте соединения — см. схему соединений.
Защита от замерзания - уровень 1	E19	2° < температура воды < 4° и температура воздуха < 0°	Остановите работу теплового насоса, слейте конденсатор, чтобы избежать замерзания; по умолчанию тепловой насос запускает фильтрационный насос для предотвращения замерзания
Защита от замерзания - уровень 2	E29	Температура воды < до 2° и температура воздуха < 0°	Остановите работу теплового насоса, слейте конденсатор, чтобы избежать замерзания; по умолчанию тепловой насос запускает фильтрационный насос и тепловой насос для предотвращения замерзания.
Неисправность двигателя вентилятора	F031	Двигатель заблокирован или есть проблема с соединением	Проверьте свободное вращение; проверьте соединение CN97/DCFan; замените двигатель
Неисправность двигателя вентилятора	F051	Ошибка соединения	Проверьте соединение DCFAN/CN97; замените двигатель
Наружная температура слишком низкая	TP	Рабочий предел достигнут	Выключите тепловой насос



## 6. ПРИЛОЖЕНИЯ (продолжение)

---

### 6.5 Гарантия

#### ГАРАНТИЙНЫЕ ОБЯЗАТЕЛЬСТВА

На всю продукцию компании HAYWARD в течение двух лет с момента приобретения распространяется гарантия отсутствия дефектов, связанных с работой или материалами. Настоящая гарантия действительна лишь при предъявлении документа, подтверждающего факт и дату покупки. В связи с этим мы рекомендуем сохранять товарный чек.

Гарантия компании HAYWARD сводится лишь к ремонту или замене, по выбору компании HAYWARD, дефектного изделия при условии его нормальной эксплуатации в соответствии с требованиями инструкции по эксплуатации, отсутствия каких-либо модификаций изделия и использования компонентов и запасных частей исключительно компании HAYWARD. Действие гарантии не распространяется на последствия воздействия мороза и химических веществ. Все прочие расходы (доставка, производство работ, ...) не включены в гарантию.

Компания HAYWARD не несет ответственности за любой ущерб, прямой или косвенный, являющийся следствием неправильной установки, подключения или работы изделия.

Для того чтобы воспользоваться гарантией и потребовать возмещения стоимости или замены изделия, обратитесь к Вашему продавцу. Возврат изделия на завод-изготовитель невозможен без нашего предварительного письменного согласия. Гарантия не распространяется на быстроизнашивающиеся детали.

### 6.6 Окончание срока службы устройства



Символ перечеркнутой корзины, обозначающий переработку и утилизацию электрических и электронных отходов, означает, что изделия, отмеченные таким символом, нельзя выбрасывать вместе с бытовым мусором, крупногабаритными предметами или на свалку.

 По окончании срока службы устройство необходимо отдать отдельно для утилизации или переработки. В странах Европейского Союза и в Норвегии создана специальная процедура утилизации такого вида изделий.

Для сбора, демонтажа и утилизации этого устройства необходимо обратиться к установщику или местному представителю.

Утилизация хладагента, масла и других деталей элементов должна выполняться квалифицированным специалистом в соответствии с региональным и национальным законодательством.

Если изделие содержит аккумуляторные батарейки, отмеченные этим символом, это означает, что аккумуляторы могут содержать вредные или загрязняющие вещества. В этом случае утилизировать аккумуляторы необходимо в пункте сбора использованных аккумуляторных батареек.

Hayward® is registered trade-  
mark  
of Hayward® Holdings, Inc.  
© 2023 Hayward® Holdings, Inc.

