

INVERX AI-WIRELESS ROBOTIC POOL CLEANER

USER MANUAL

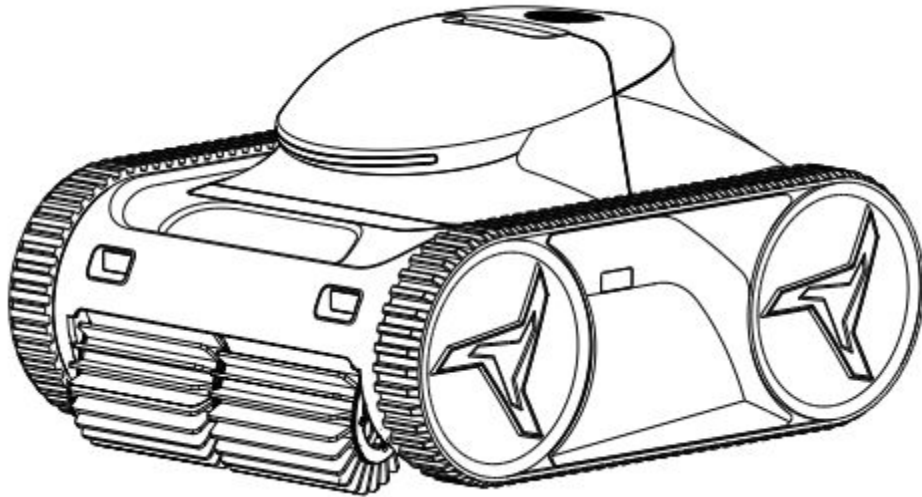

Model: X30 / X45 / X60 / X80

THANK YOU FOR PURCHASING THE INVERX AI-WIRELESS ROBOTIC POOL CLEANER.

Please read the manual thoroughly before installing or using the product.

Keep this manual for future reference.



IMPORTANT WARNINGS & SAFETY INFORMATION

This manual contains important information about the installation, operation, and safe use of this product. This information should be given to the owner and/or operator of the robot. When installing and using the robot, basic safety precautions should always be followed. Failure to follow safety warnings and instructions in this manual can result in serious injury and/or damage to your equipment. Read and follow all warning notices and instructions which are included in this manual.

GENERAL WARNINGS

- Read the instructions before operating the robot.
- The robot is designed for pool cleaning; do not use it for any other purpose.
- Keep the robot out of the reach of children or persons with reduced physical, sensory, or mental capabilities, or lack of experience and knowledge, unless they have been given supervision or instruction.
- Children should not play with the robot.
- The robot must be maintained by a qualified professional except for simple routine maintenance written in this manual.
- Installers/operators must follow manufacturer's instructions and keep in compliance with national or local standards for installation. Under no circumstances will the manufacturer be held responsible for any outcome incurred by failure to comply with applicable standards or local regulations.
- Incorrect installation or use of the robot may cause serious damage to property or injuries to people, and will void the warranty.
- Do not use the robot when people or animals are in the pool.
- Disclaimer: Information in this manual is intended to provide general information on a particular subject(s) in good faith and is not an exhaustive treatment of such subject(s). Its use is beyond the control of the author, contributor, publishers, and distributors and should not be relied upon without consulting your local Professional for comprehensive advice. This manual includes subject(s) that should only be performed by or under the direction and advice of your local Professional and under no circumstances should the manual be used as a substitute for such professionals. No representations or warranties are made that the content, advice, and recommendations in this manual are current, free from errors or omissions, or appropriate for the user's circumstances or abilities. No liability is accepted for any loss suffered as a result of any user's reliance on such content.

WARNINGS ON USE

- Only use the provided/genuine charger when charging the robot.
- Only charge the robot indoors.
- The robot's charger **MUST BE DISCONNECTED** before conducting any maintenance on the robot.
- Do not operate the robot with wet hands.
- Do not try to repair the robot yourself or open the engine box. In case of malfunction or for any issues not covered in the Troubleshooting Guide, please contact your authorised dealer.
- If there is any malfunction or release of odour from the robot when charging, disconnect it from the power supply immediately and contact your authorised dealer.
- Use only genuine replacement parts supplied by the manufacturer for service and repair.
- For battery protection, the robot should be fully charged every 3 months.
- The magnetic safety cap should be re-inserted into the robot if the robot is not going to be used for more than 14 days.
- Do not expose the robot to extended periods of sun exposure. When the robot is not in use, ensure it is fully dry and store the robot in an undercover, cool dry place away from direct sunlight.
- This product contains electrical equipment. Dispose of the product in accordance with local regulations.

GENERAL OPERATING CONDITIONS

- Water depth range: 1m – 2.5m.
- Water temperature range: 4°C – 35°C. The endurance time of the robot may be affected when the water temperature is below 15°C.
- Pool water pH: 7.0 – 7.8
- Salt level: 5000ppm maximum
- Chlorine level: 4ppm, maximum
- To protect the motor, the robot will automatically stop running if the water depth is less than 40 centimeters.
- Do not use the robot during shock chlorination – remove the robot completely from the pool water.
- Do not use the robot during a thunderstorm.
- Do not charge the robot outdoors.
- Do not expose the robot to direct rainfall or sunlight for an extended period.
- Ensure the robot is completely dry before storing it away. When the robot is not in use, store it in an undercover, cool dry place away from direct sunlight. Recommended storage temperature for the robot is between -10°C and 45°C, and relative humidity 30%-70%.



CAUTIONS

- To drain the water from the robot, place the robot on the edge of the pool and hold it on an angle to let the water drain out into the pool.
- Lift the robot slowly out of the water to prevent back injury.
- Clean the filter basket after each cleaning cycle.
- Do not lift the robot out of the water by its track(s).



REMINDER

- When the robot battery is below 30%, it will clean the floor of the pool only.
- Robot must be fully dry before storing.
- Filter basket should be cleaned thoroughly after each use, do not let debris dry up in the basket.
- Charger cable must be stored neatly without twists or tangles.
- Optimum storage temperature is -10 °C – 45°C

Table of Contents

SECTION 1. PRODUCT OVERVIEW	4
1.1 Packaging Contents	4
1.2 Technical Specifications	5
1.3 Preparation	6 - 7
SECTION 2. OPERATION	8
2.1 Control Panel Buttons	9 - 10
2.2 Startup and Operation of the Unit	10 - 11
2.3 Pool with a Sloped Beach Entry	11
2.4 Cleaning the Filter Basket	12 - 13
2.5 Charging the Robot	13 - 14
2.6 WIFI Connection	14
SECTION 3. MAINTENANCE	14
3.1 Filter Maintenance	15
3.2 Impeller Maintenance	15- 16
3.3 Replacing Worn Brushes	16 - 17
3.4 Replacing Worn Track Belts	17 - 19
SECTION 4. TROUBLESHOOTING	19 - 20
SECTION 5. SCHEMATICS	21 - 22
SECTION 6. WARRANTY	23
SECTION 7. PRODUCT REGISTRATION	23

SECTION 1. PRODUCT OVERVIEW

1.1 Packaging Contents

The following items are included in the packaging of the robot. Please contact your dealer if any items are damaged or missing.

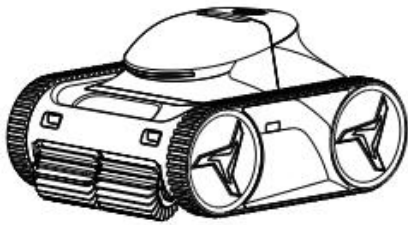

①

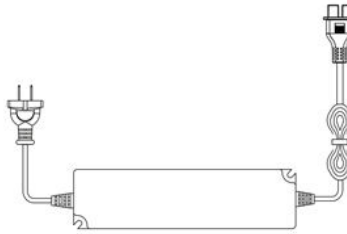

②



③

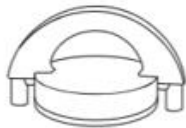

④

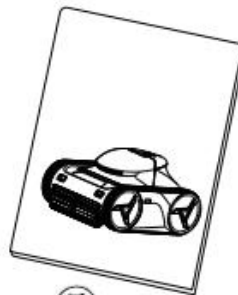

⑤

① Robot cleaner	② Charger	③ Hook	④ Magnetic safety cap x 2	⑤ User manual
-----------------	-----------	--------	---------------------------	---------------

Note: The magnetic safety cap is a safety feature of the robot. When the magnetic cap is inserted underneath the robot, the robot is unable to be turned on. Remove the magnetic cap ④ when operating the robot or charging the robot. The magnetic cap should be re-inserted into the robot if the robot is not going to be used for more than 14 days.

Note: If the robot encounters an error, restart the robot by inserting the magnetic safety cap for 5 seconds, then removing it.

1.2 Technical Specifications

	Model X80	Model X60	Model X45	Model X30
Endurance Time – Floor Mode	8h	6h	4.5h	3h
Endurance Time – Floor/Wall/Waterline Mode	4.5h	3.5h	2.5h	2h
Charging Time	8h	6h	4.5h	3h
Battery	14Ah (352wh)	10.4Ah (262wh)	7.8Ah (196wh)	5.2Ah (131wh)
Ideal Pool Water Temperature Range	Between 4°C and 35°C			
Cleaning Modes	Floor Only / Floor, Wall & Waterline			
Multiple Cycle Options	0.5h / 1h / 2h			
AI Timer	Clean every 24h / 48h / 72h			
Mobile Device App Available	Yes			
Filter Capacity	3.2L			
Filtration Accuracy	180µm (80mesh)			
Pump Flow Rate	22-15m³/h		20-15m³/h	
Running Power	30-110W			
Moving Speed	12m/min			
Number of Motors	3			
Charger Input	100-240VAC ~ 50/60Hz			
Running Voltage/Current	25.2V/1.2A			
Charger Power	72.5W			
Robot Net Weight	12kg	12kg	11.5kg	11.5kg
Robot Gross Weight	17kg	17kg	16.5kg	16.5kg
Robot Dimensions (LxWxH)	495x395x265mm			
Robot Packaging Dimensions (LxWxH)	580x448x330mm			

Note: The abovementioned endurance times are based on a 2 hour cleaning cycle in Floor mode in a vinyl lined pool.

Note: The manufacturer reserves the right to modify these specifications without notice.



1.3 Preparation

1. Ensure the robot is turned off. Remove the magnetic safety cap from underneath the robot and store it in a safe place. Do not lose the magnetic cap.

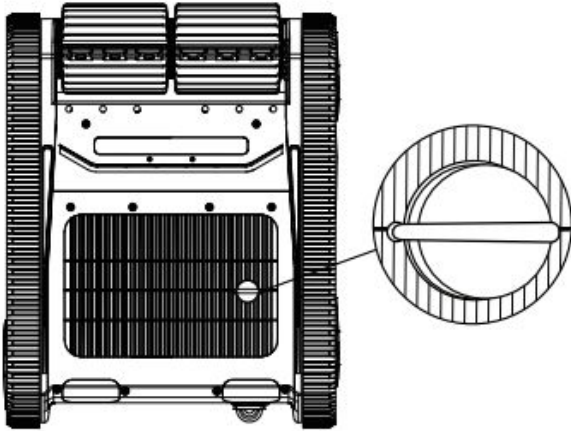

2. Take the cover off the charging port. The charging port cover will remain tethered to the robot's body – do not lose the charging port cover. Do not submerge the robot in water without the charging port cover inserted into the charging port.

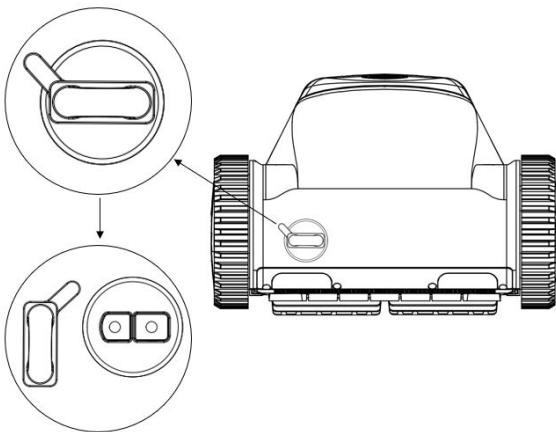

3. Ensure the charging port on the robot, and the charger, are dry. Plug the charger into the robot, ensuring the plug is turned the correct way to line up with the charging port.



4. Plug the other end of the charger into a 240V power supply. When  on the robot is flashing green, the robot is charging.

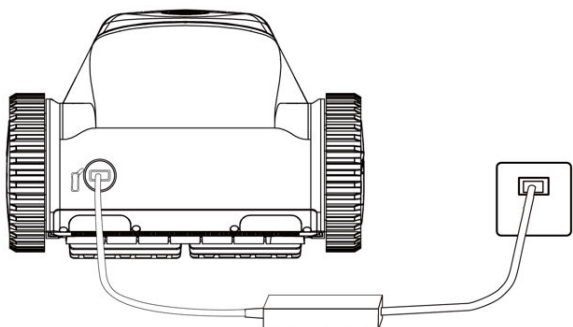

When  on the robot has 3 green lights on, the robot is fully charged. **Note: Please fully charge the robot before the first use.**

5. Once the robot is fully charged, turn the power off at the wall, then unplug the charger from the robot and the power supply. Store the charger in a safe place. To protect the battery, do not leave the charger plugged into the robot after charging has completed.
6. Re-insert the charging port cover back into the robot.

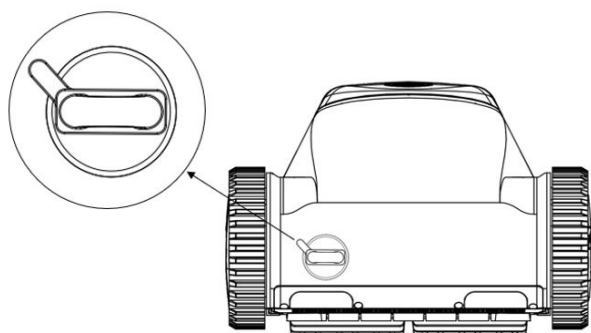

Note: Do not charge the robot outdoors.

Note: Recommended ambient temperature for charging is 6°C – 35°C.

Note: Only use the genuine charger to charge the robot. Using any other charger will void the warranty.

7. Install the hook onto your telepole. (Telepole not included). This hook is to help you lift the robot up to the surface of the pool water when you want to remove the robot from the pool.

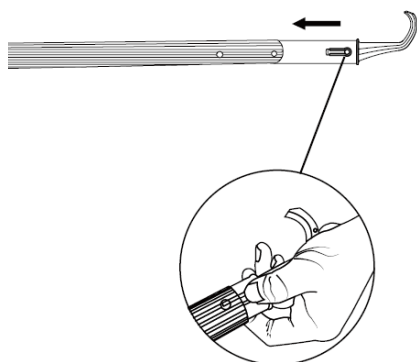

SECTION 2. OPERATION

⚠ CAUTION

To prevent possible damage to the robot, injury to people or voiding your warranty, please follow these guidelines:

- Use the hook (attached to your telepole) to lift the robot from the bottom of the pool to the surface of the pool water. Then use your hands to lift the robot onto the edge of the pool, using the robot's handle. Do not lift or carry the robot by the tracks or any other part of the robot.
- Do not use the hook to lift the robot out of the water, only use the hook to bring the robot to the surface of the water.
- The robot is heavier when filled with water. Place the robot on the edge of the pool and hold it on an angle to let the water drain out into the pool.
- After cleaning is completed, ensure robot is fully dry and store the robot in an undercover cool dry place away from direct sunlight.
- Once you have selected the operating settings on the robot, place the robot into the pool water (we recommend the corner of the pool) within 3 minutes, otherwise the robot will enter Sleep mode. If the robot has entered Sleep mode, hold the  button for 3 seconds to turn the robot on, and re-select your settings.
- Clean the filter basket after each cleaning cycle. Avoid cleaning the surface of the filter box directly with your hands.
- When placing the robot into the pool water, ensure it is fully submerged, then gently tilt the robot slightly in all directions to ensure any air contained in the robot is released.

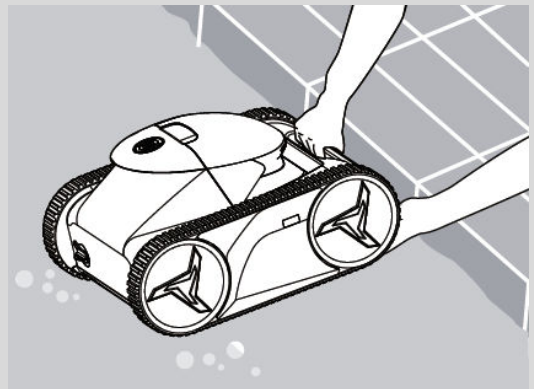



IMPORTANT NOTE

To protect the motor, the robot will automatically stop running if the water depth is less than 40 centimeters.

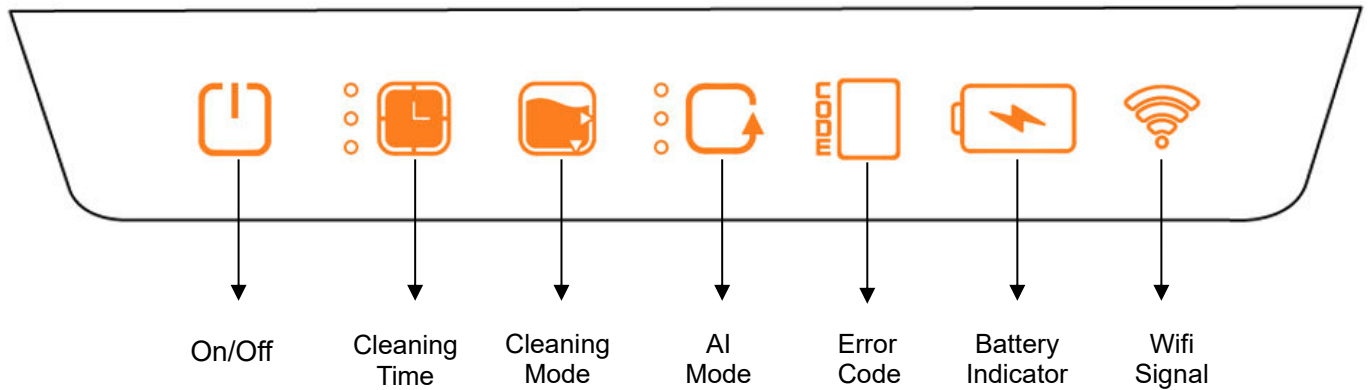
2.1 Control Panel Buttons









Button	Icon	Display Status	Description
Power (on/off)		Green light flashing	Robot is starting up
		Green light on (solid)	Robot is running
Cleaning time		1 green light on	Clean for 0.5 hours
		2 green lights on	Clean for 1 hour
		3 green lights on	Clean for 2 hours*
		All lights off	Clean until battery is low
Cleaning mode		Bottom/floor triangle green light on	Floor cleaning mode
		Both triangle green lights on	Overall cleaning mode (Floor, wall, waterline)
AI Mode		1 green light on	Clean every 24 hours
		2 green lights on	Clean every 48 hours
		3 green lights on	Clean every 72 hours
		All lights off	AI Mode is off
Error code		1	Left drive error
		2	Right drive error
		3	Water pump error
		4	Control panel communication error
		5	Infrared sensor error
		6	Water sensor error

Button	Icon	Display Status	Description
Battery indicator (when robot is not charging)		1 green light on	Battery level: 20-50%
		2 green lights on	Battery level: 50-75%
		3 green lights on	Battery level: 75-100%
Low battery		1 red light flashing	Battery level: 15-20%
Battery indicator (when robot is charging)		1 green light flashing	Battery level: 0-50%
		1 green light on, 2 green light flashing	Battery level: 50-75%
		2 green lights on, 1 green light flashing	Battery level: 75-100%
WIFI signal		3 green lights on	Battery level: 100%
		Green light flashing	Searching for network
		Green light on	Connected to network
		Red light on	No network connection
		Red light flashing	Network connection failure

***Note:** If the cleaning time is set to be more than 2 hours via the App, there will also be 3 lights on.

2.2 Startup and Operation of the Unit

1. Remove the magnetic safety cap from underneath the robot; the robot will automatically turn on. If the magnetic safety cap has previously been removed from underneath the robot, hold down  for 3 seconds to turn on the robot. When  flashes, you can begin setup/programming of the robot. After setup, press  once to confirm your settings and immediately commence the cleaning cycle. If you have selected an AI Mode  you also have the option to continuously press  for 3 seconds to delay the commencement of the cleaning cycle.

EXAMPLE: If you select the AI Mode for “cleaning every 24 hours” then press  once, the cleaning cycle will commence immediately. After one cleaning cycle, the robot will enter Sleep mode and automatically wake up and start the cleaning cycle after 24 hours.

If you select the AI Mode for “cleaning every 24 hours” then press  continuously for 3 seconds, the robot will enter Sleep mode at first. After 24 hours, it will start cleaning automatically.

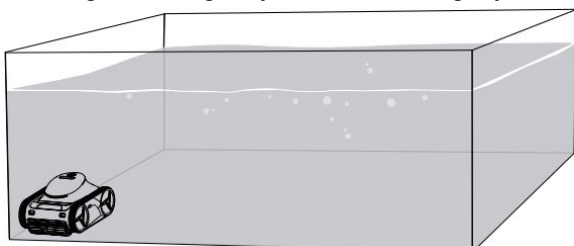

2. Place the robot into the pool water (we recommend the corner of the pool) within 3 minutes of setting the program, otherwise the robot will enter Sleep mode. When placing the robot into the pool water, ensure it is fully submerged, then gently tilt the robot slightly in all directions to ensure any air contained in the robot is released.

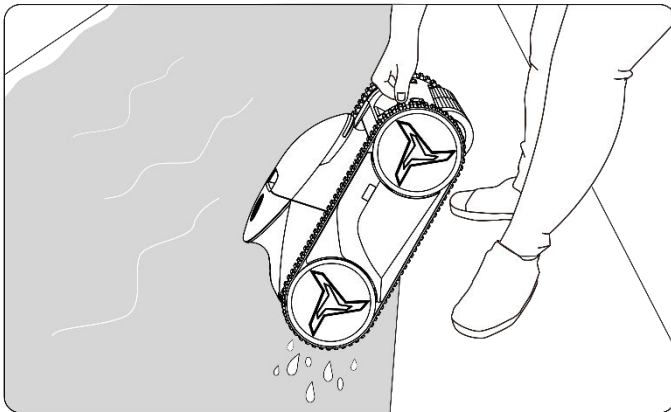

3. The robot will start cleaning automatically after it reaches the floor (unless you chose a delayed start for one of the AI modes).
4. If the battery reaches less than 15% charge during a cleaning cycle,  will flash 1 red light, the robot will automatically go to the side of the pool then enter into Sleep mode after 5 minutes.
5. To remove the robot from the pool, use the hook (attached to your telepole) to hook onto the robot's handle, and lift the robot from the bottom of the pool to the surface of the pool water. Then use your hands to lift the robot onto the edge of the pool, by holding it by the handle.
6. Do not lift or carry the robot by the tracks or any other part of the robot. Do not use the hook to lift the robot out of the water, only use the hook to bring the robot to the surface of the water. The robot is heavier when filled with water. Pay special attention when lifting it out of the water.
7. Place the robot on the edge of the pool and hold it on an angle to let the water drain out into the pool.



Note: The robot will stop at the side of the pool if a fault occurs, or when the battery level is less than 15%.

Note: If a fault occurs, an error code will appear on the control panel (see 2.1) and  will flash red. Pressing  will remove the error code and the robot will enter the setup mode.

2.3 Pools with a Sloped Beach Entry

To protect the motor, the robot will automatically stop running if the water depth is less than 40cm. To reduce the frequency of the robot stopping on the beach entry, it is recommended that you:

1. Run the Floor Mode cycle first, to ensure the entire floor is cleaned without interruption.
2. Then run Overall mode to clean the walls.
3. Place the robot in the opposite end of the pool.
4. Place the robot at a 90° angle to the beach entry.

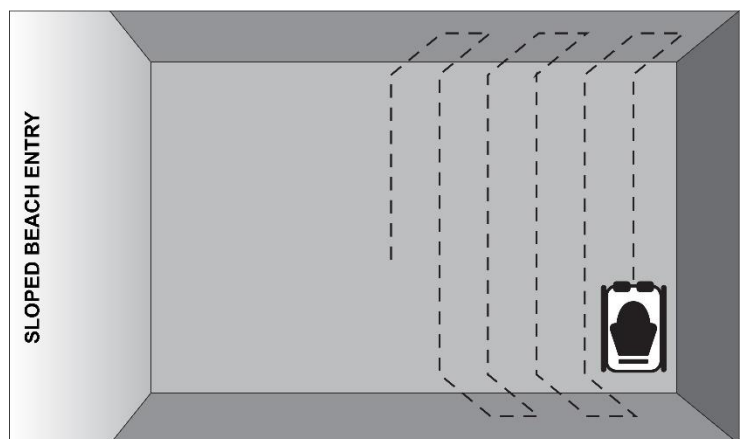

2.4 Cleaning the Filter Basket

1. Clean the filter basket after each cleaning cycle. When a cleaning cycle is complete, the robot will stop at the side of the pool.
2. Use the hook (attached to your telepole) to hook onto the robot's handle, and lift the robot from the bottom of the pool to the surface of the pool water. Then use your hands to lift the robot onto the edge of the pool, by holding it by the handle.
3. Do not lift or carry the robot by the tracks or any other part of the robot. Do not use the hook to lift the robot out of the water, only use the hook to bring the robot to the surface of the water. The robot is heavier when filled with water. Pay special attention when lifting it out of the water.
4. Place the robot on the edge of the pool and hold it on an angle to let the water drain out into the pool.
5. Ensure the robot is turned off.
6. Remove the filter basket, then open the basket:

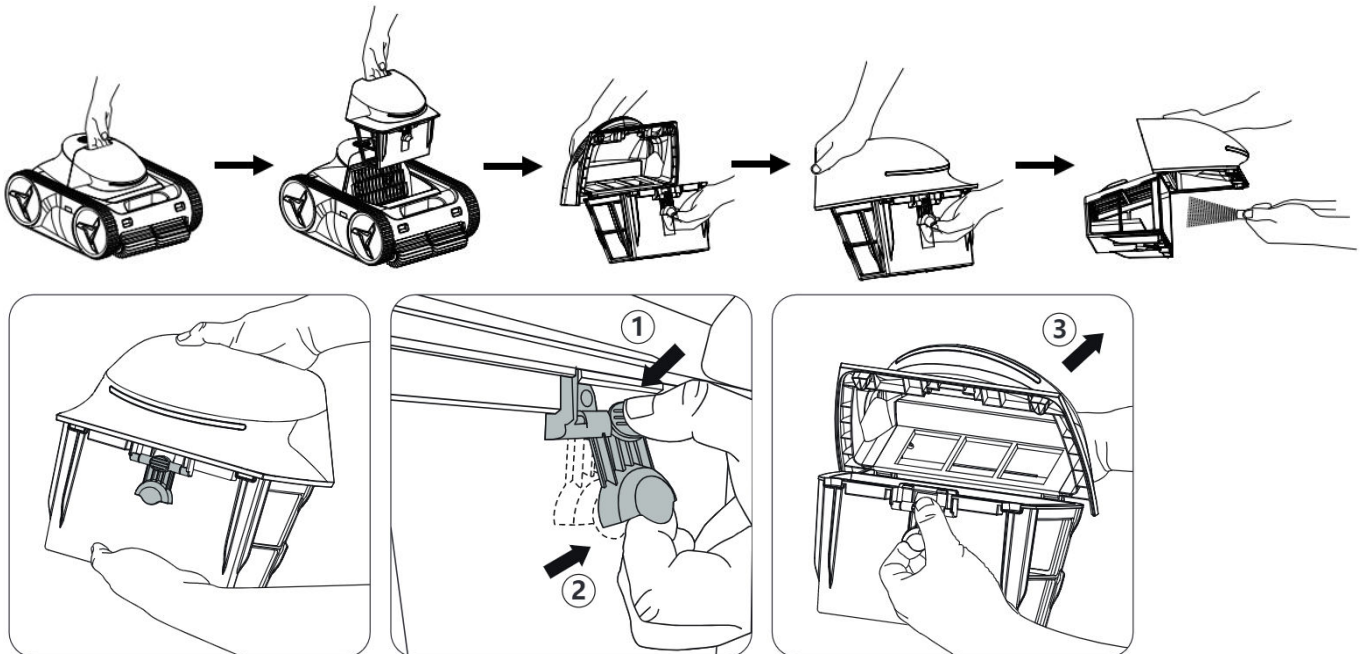

7. Empty any debris and clean the basket with a hose or by running under a tap. Ensure there are no holes in the basket's mesh.

Note: There is a risk of being injured by debris if cleaning the filter basket with your hands. It is recommended to wear thick rubber gloves while cleaning the basket.

8. Check the water inlet is free of debris and clean accordingly.

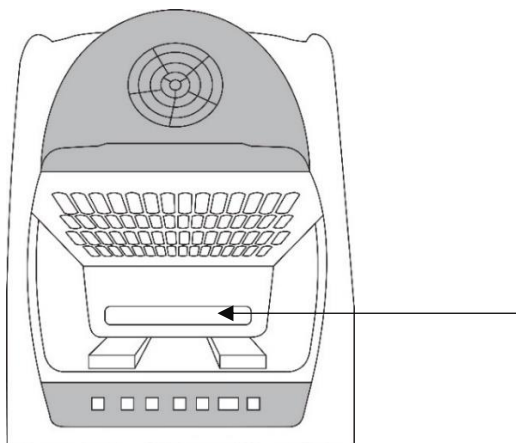

9. Close the basket and re-insert the basket into the robot, ensuring both magnets reconnect.

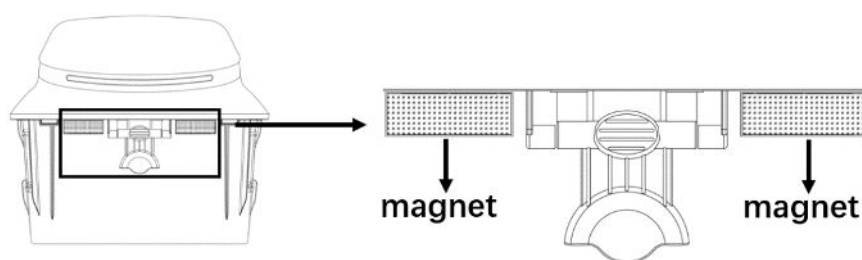

2.5 Charging the Robot

1. Take the cover off the charging port. The charging port cover will remain tethered to the robot's body – do not lose the charging port cover. Do not submerge the robot in water without the charging port cover inserted into the charging port.

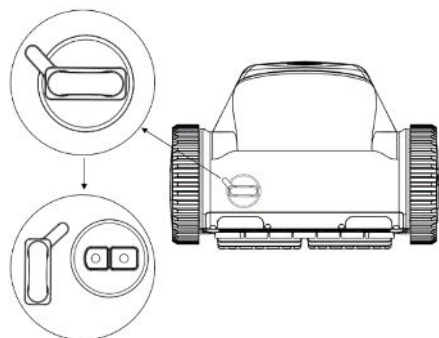

2. Ensure the charging port on the robot, and the charger, are dry.
3. Plug the charger into the robot first and then into a 240V power supply. When the battery light on the robot is flashing green, the robot is charging.

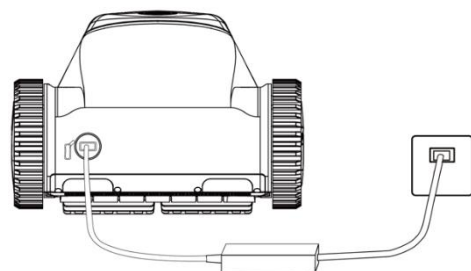



4. When the the battery light on the robot has 3 green lights on, the robot is fully charged. Note: Fully charge the robot before the first use.
5. Once the robot is fully charged, turn the power off at the wall, then unplug the charger from the robot and the power supply. Store the charger in a safe place. To protect the battery, do not leave the charger plugged into the robot after charging has completed.
6. Re-insert the charging port cover back into the charging port on the robot.
7. If the robot will not be used for an extended period of time, it should be fully charged at least every three months to protect the battery.
8. Do not charge the robot outdoors.

Note: Only use the genuine charger to charge the robot. Using any other charger will void the warranty.

2.6 WIFI Connection

1. Ensure your mobile device is connected to WIFI. On your mobile device, download the “AI-BOT” app in the Apple iOS App Store or the Google Play Store. You will need to create an account in the AI-BOT app. Ensure you allow the app to access Notifications, Bluetooth and WIFI.



2. To begin connecting your robot with the app, hold  for 3 seconds. The robot will beep and  will flash green to indicate it is in pairing mode.
3. In the “AI-BOT” app, tap the “Add Device” button to begin searching for the robot. Follow the prompts in the app to connect your mobile device to the robot.
4. When the app and the robot are successfully paired/connected,  will be green.
5. You will now be able to control the robot from the app.

Note: The robot must be on and programmed manually first, then you can use the app to change various settings.

Note: Do not perform this setup when the robot is in the pool as the water may cause signal interference.

SECTION 3. MAINTENANCE

⚠ WARNING

1. To avoid electric shock and other hazards which could result in major injuries, ensure the robot is disconnected from the charger before performing any cleaning and/or maintenance.
2. Before any maintenance, be sure to insert the magnetic cap underneath the robot to prevent any parts from moving and causing injury.

3.1 Filter Maintenance

1. Clean the filter after each cleaning cycle to ensure optimum cleaning and climbing performance. Refer to Section 2.3 for filter cleaning instructions.
2. Annually clean the filter with mild acidic detergent. Safety equipment must be worn when carrying this out.

3.2 Impeller Maintenance

If you have any difficulties performing impeller maintenance, please contact your authorised dealer for assistance.

1. Ensure the robot is turned off and the magnetic safety cap is inserted underneath the robot.

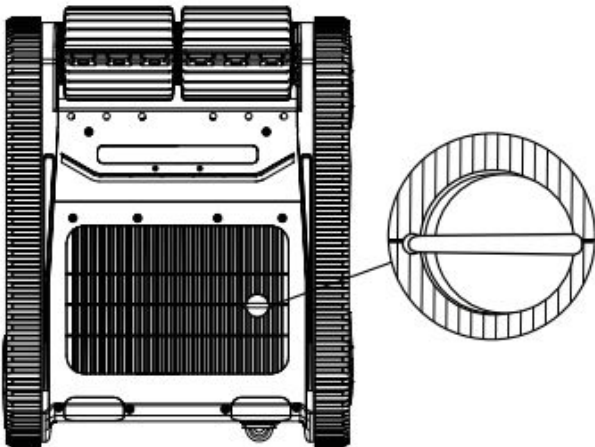

2. Take out the filter box.
3. Remove the 2 housing screws and take off the housing.
4. Remove the styrofoam insert.
5. The impeller has sharp edges, please ensure you wear protective gloves while handling the impeller.
6. Remove the 4 x impeller cover screws and take off the impeller cover.

7. Remove 1 x impeller screw and take off the impeller. This screw has an opposite thread and must be unscrewed clockwise to undo the screw.
8. Visually check the impeller and impeller shaft for any hair or other debris, and clean if necessary. Hair or debris in the impeller or impeller shaft may cause reduced suction or climbing performance.

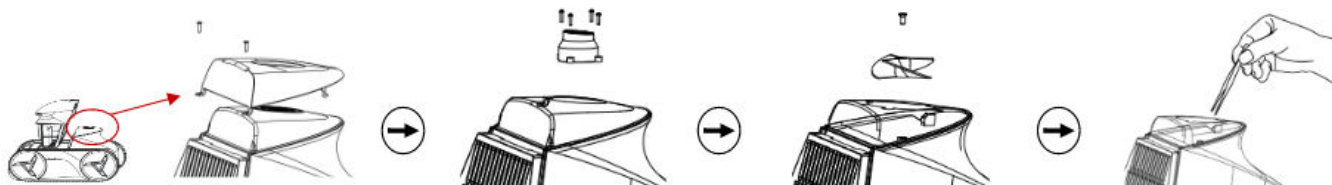

9. Reassemble the robot by following these steps in reverse order.

3.3 Replacing Worn Brushes

1. Ensure the robot is turned off and the magnetic safety cap is inserted underneath the robot.

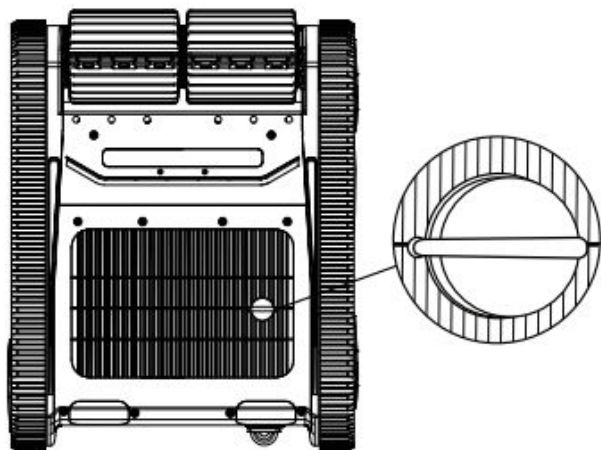

2. Turn the brush by hand until you can see the row of connection tabs.

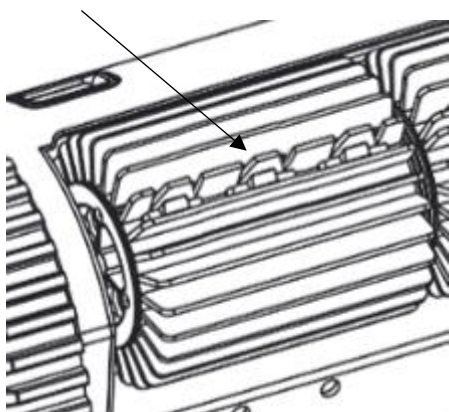

3. Undo each tab, then remove the brush.

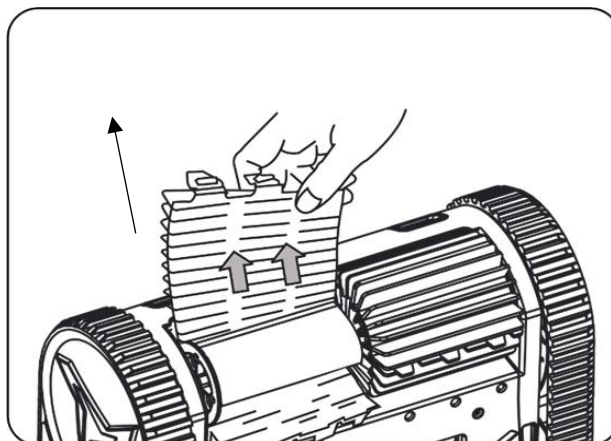
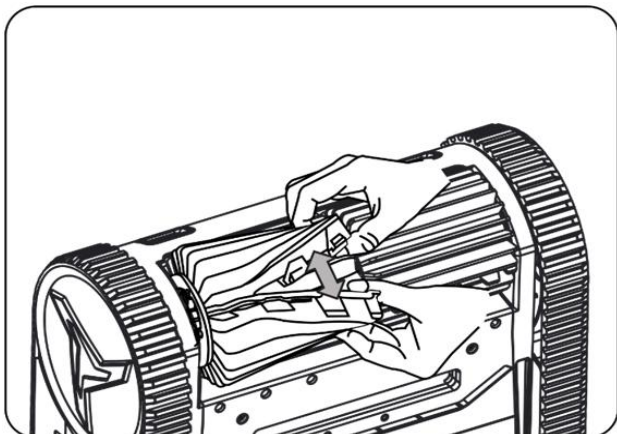

4. Take your new brush and insert the edge without the tabs under the brush holder. Ensure the brush is inside the raised edges of the roller.

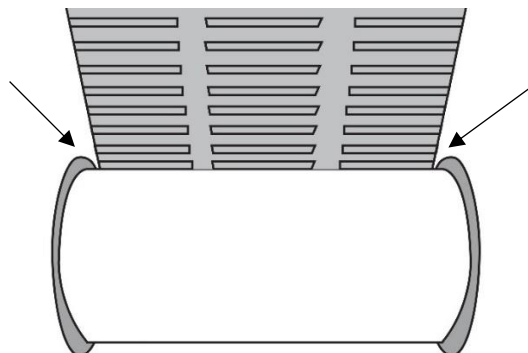
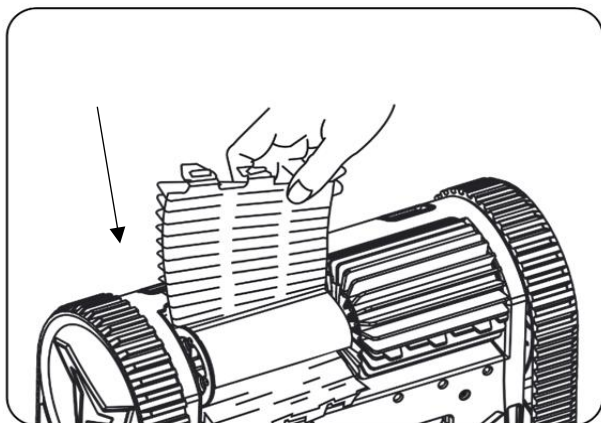

5. Pull the brush around the roller and fasten each connection tab. Pull on the end of each tab until its edges pass through the slits.

3.4 Replacing Worn Track Belts

1. Ensure the robot is turned off and the magnetic safety cap is inserted underneath the robot.

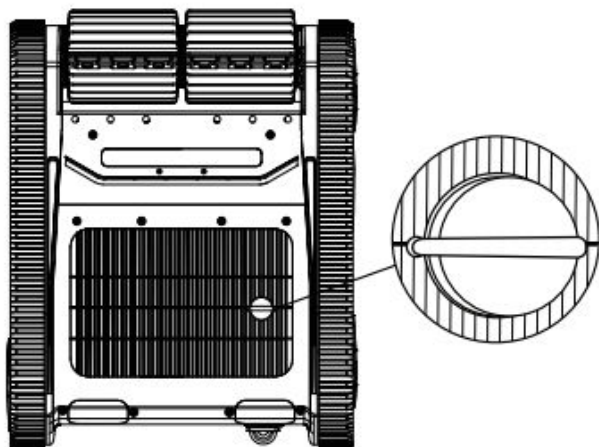

2. Place the robot on its side then remove the worn track belt by peeling it up and away from the robot.

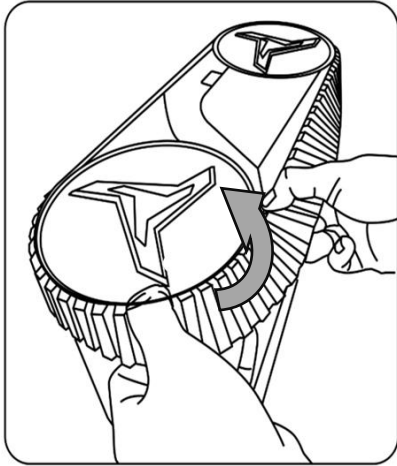

3. Position the new track belt by wrapping it around the small front wheel first.

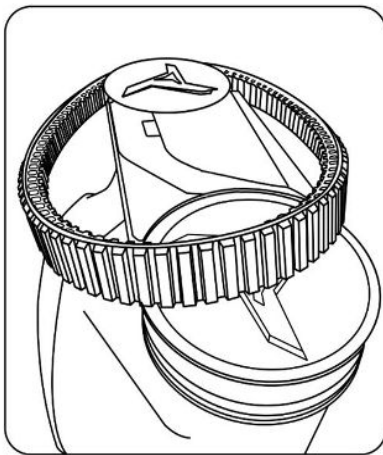

4. Ensure the track belt is orientated so the teeth on the inside of the belt are closest to the outside of the cleaner.

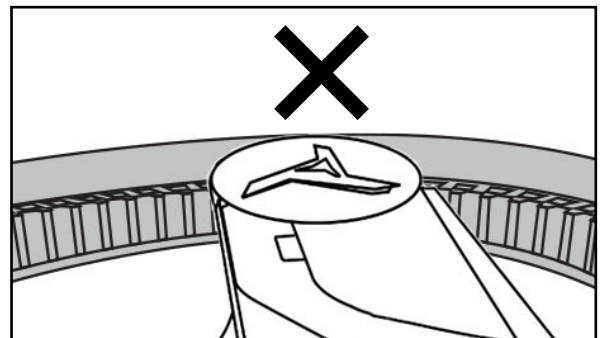
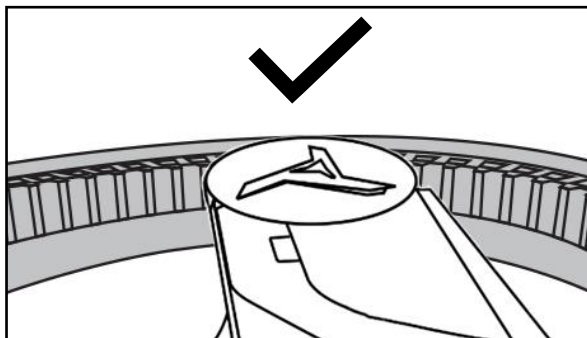

5. Ensure the belt is sitting correctly in the grooves of the small front wheel. Pull the track belt over the rear large wheel as much as possible.

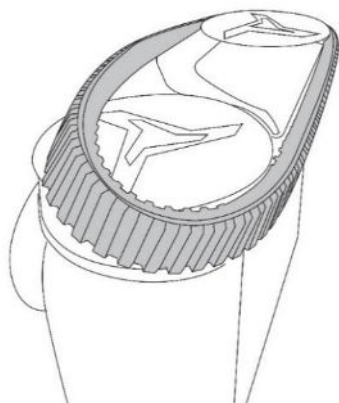

6. Hold the belt on the large rear wheel with a downward pressure, while pushing the track belt so it turns the wheels. The track belt should slowly latch on to the wheel as you are turning the belt/wheels. Check the track belt fits correctly all the way around.

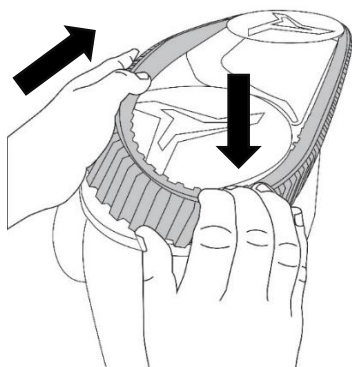

SECTION 4. TROUBLE SHOOTING

In addition to the below troubleshooting, also see Section 2.1 for error code identification. Pressing the power button on the robot, or charging the robot, will clear any error codes. Contact your authorised dealer if an error code cannot be cleared. Please note the robot will stop at the side of the pool if it encounters a failure, or when the battery is less than 15% charged.

Problem	Possible Cause	Solution
Robot doesn't charge	Debris on the electrode of the charging head	Clean debris
	The magnetic safety cap isn't removed	Remove the magnetic safety cap from underneath the robot (Refer to Section 1.3, Step 1)
	Charger is damaged	Replace charger
Robot doesn't turn on	The magnetic safety cap isn't removed	Remove the magnetic safety cap from underneath the robot (Refer to Section 1.3, Step 1)
	Water spots on the robot display or people's hand	Dry the display, then try again
	Pressing the wrong buttons	Hold the power button for 3 seconds
	No power in the battery	Charge the robot (Refer to Section 2.5)

Problem	Possible Cause	Solution
Robot not moving or pumping water	Low battery	Charge the robot (Refer to Section 2.5)
	Robot is not submerged in enough water	Ensure the robot is submerged under a minimum of 40cm of water, and ensure the robot is turned on
	Power button was not pressed after selecting settings	Press the power button after you have selected the settings. Ensure the correct lights are on before putting the robot into water
	Filter basket is full	Clean the filter basket (Refer to Section 2.4)
Robot is moving but not pumping water	The impeller is stuck	Check and clean the impeller (Refer to Section 3.2)
	Filter basket is full	Clean the filter basket (Refer to Section 2.4)
	Water inlet is blocked	Remove the filter basket and clean the water inlet (Refer to Section 2.4)
	Battery low	Charge the robot (Refer to Section 2.5)
Robot is pumping water but not moving	The drive motor is stuck	Please contact your authorised dealer for replacement
	Track belt is deviated and stuck	Turn the robot on its side and roll the track forward and backward to restore the track. Repeat on the other track
	Track belt is damaged	Replace track belt (Refer to Section 3.4)
	Brushes are stuck	Ensure there are no obstacles or debris stuck in the brushes/rollers
	The robot gets stuck by an obstacle and shuts down for auto-protection	Remove obstacle and restart the robot
	Filter basket is full	Clean the filter basket (Refer to Section 2.4)
Robot is not climbing	Robot is set to floor cleaning mode only	Set the robot to the overall cleaning mode
	The impeller is stuck	Clean the impeller (Refer to Section 3.2)
	Filter basket is full	Clean the filter basket (Refer to Section 2.4)
	Water inlet is blocked	Remove the filter basket and clean the water inlet (Refer to Section 2.4)
Poor cleaning capability	Battery is low	Charge the robot (Refer to Section 2.5)
	The impeller is stuck	Clean the impeller (Refer to Section 3.2)
	Filter basket is full	Clean the filter basket (Refer to Section 2.4)
	Water inlet is blocked	Remove the filter basket and clean the water inlet (Refer to Section 2.4)
	Brushes are damaged	Replace the brushes (Refer to Section 3.3)
	Filter basket is damaged	Replace the filter basket
Robot is not behaving correctly	Software failure	Reset the robot by inserting the magnetic safety cap underneath the robot for 5 seconds, then remove it and restart the robot

SECTION 5. SCHEMATICS

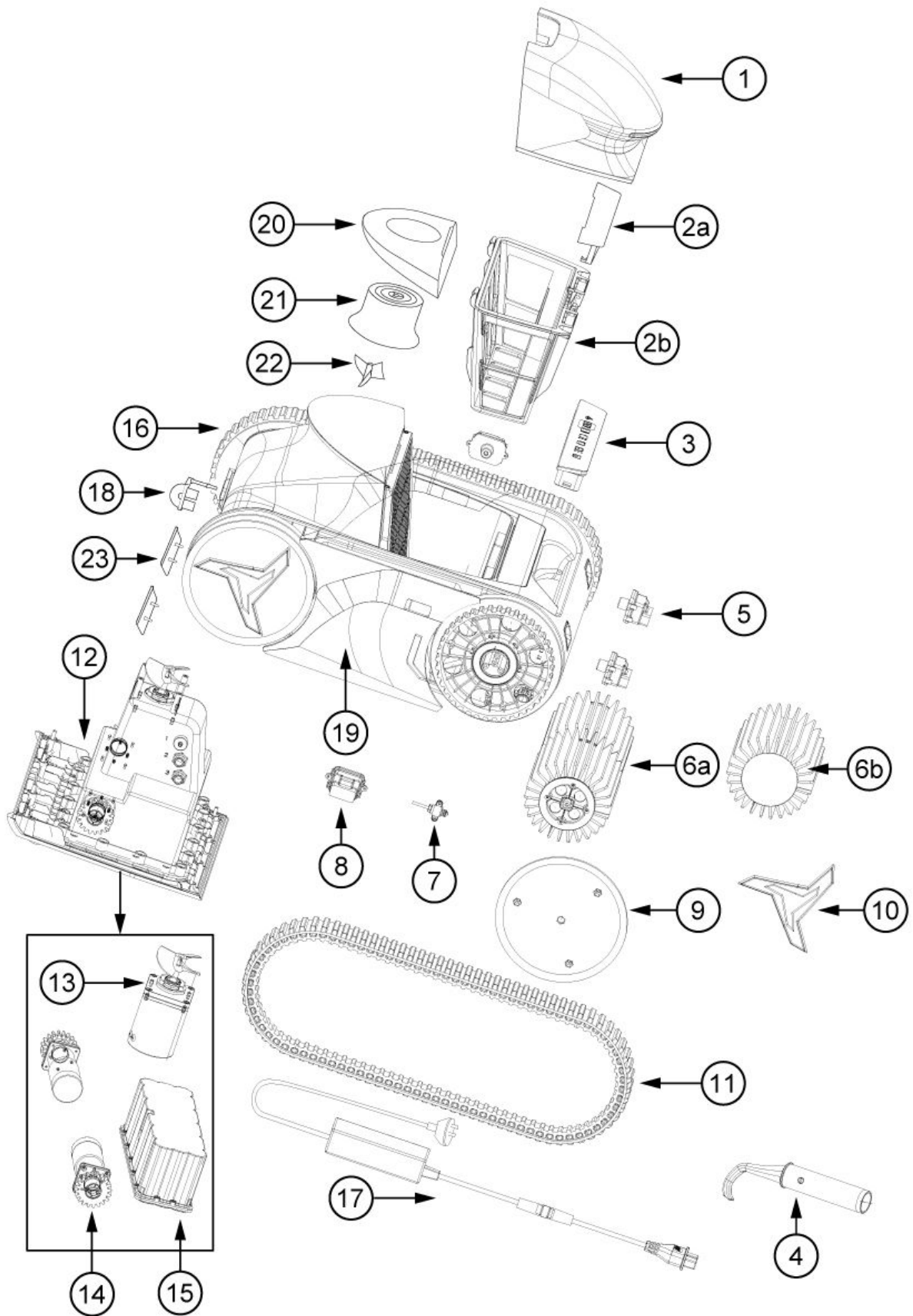

#	PART
1	Filter Top Cover
2a	Filter Bracket Assembly w/ Screws
2b	Main Filter Cartridge
3	Control Panel
4	Hook
5	Front Infrared Sensor
6a	Brush Assembly w/ Screws
6b	Brush Only
7	Out-of-water Sensor
8	Side Infrared Sensor
9	Wheel Cover w/ Screws
10	Decorative Wheel Trim
11	Track Belt
12	Motor Box Assembly
13	Water Pump Motor
14	Drive Motor
15	Battery
16	Body Assembly
17	Charger Assembly
18	Charging Port Cover
19	Left Side Cover w/ Screws
<i>Not Shown</i>	Right Side Cover w/ Screws
20	Impeller Cover Surround w/ Screws
21	Impeller Cover
22	Impeller w/ Screws
23	Drain Port Flap
<i>Not Shown</i>	Bearing End Cap w/ Screws
<i>Not Shown</i>	Drive Wheel
<i>Not Shown</i>	Plastic Wheel Bearing
<i>Not Shown</i>	Magnetic Safety Cap

SECTION 6. WARRANTY

- The warranty for the X30, X45, X60 and X80 robotic pool cleaner covers manufacturer's defects in materials and workmanship for:
 - 3 years on the battery
 - 2 years on non-wearing parts
 - 12 months on wearing partsStatutory 12 months warranty applies if purchased online through a non-Pool Pro Certified Dealer.
- The warranty is only valid for the original purchaser and is non-transferable.
- Adverse operating conditions beyond the control of the manufacturer such as improper voltage, excessive ambient temperature or any condition that adversely affects the performance of the equipment will render this warranty null and void.
- Defective equipment must be returned to the authorised dealer as soon as the purchaser becomes aware of the defect and all transport costs must be prepaid.
- Neither the manufacturer nor the authorised dealer shall be responsible for any goods damaged in transit.
- Any liability of the manufacturer pursuant to the Trade Practices Act 1974, as amended for a breach of a condition or warranty shall be limited to replacing or acquiring the equipment (or part thereof) where the same has been supplied.
- The maximum liability incurred by the manufacturer shall not in any case exceed the contract price for the equipment or the product parts or components thereof claimed to be defective. Further, the manufacturer shall not be liable for any loss, damage or delay directly or indirectly caused by any malfunction of or defect of or failure of the equipment other than as expressly provided in this warranty.
- The manufacturer and authorised dealer will not be held liable for damage caused to the pool surface and coping materials.
- Keep your original purchase invoice and serial number in a safe place.

Warranty is void under the following circumstances:

- Incorrect operation of the unit by not following correct instructions.
- Improper maintenance and balancing of pool water.
- Damage caused to the robot due to misuse or damage caused by any other means than manufacturer defect.
- If the robot is repaired or serviced by an unauthorised dealer or serviceman.
- If the battery seal is damaged.
- If the battery is overcharged by using a non-genuine charger.
- If a fault occurs in the operation of the machine by using non-genuine accessories.
- If the robot has been misused, neglected, damaged or altered in any way.
- General wear and tear of consumable products (Filter Basket, Tracks, Brushes)

To submit a warranty request, visit www.poolpro.com.au/serviceclaim.

SECTION 7. PRODUCT REGISTRATION

Please register your product online at www.poolpro.com.au/product-registration within 30 days from date of purchase, or any warranty claim may be voided.



AX-FLR038-A1