

DEBURR & BREAK ALL SHARP EDGES
UNLESS SPECIFIED

DO NOT SCALE PRINT

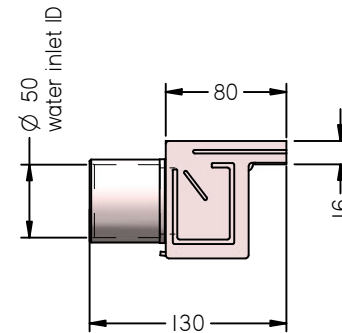
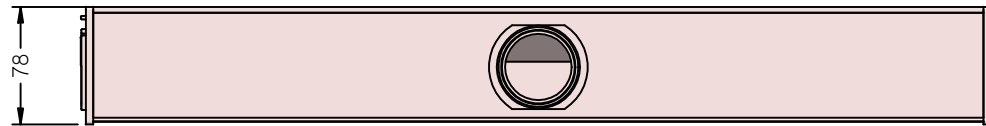
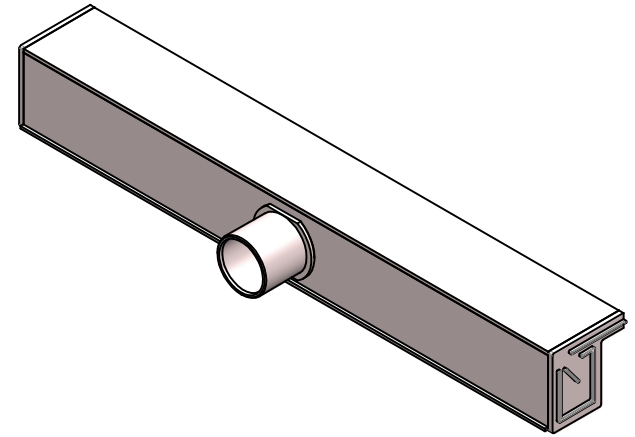
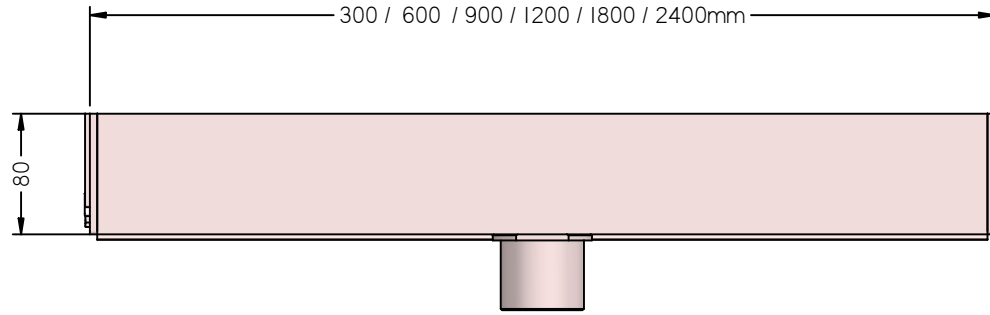

DIMENSIONS IN mm UNLESS OTHERWISE SPECIFIED

GENERAL TOLERANCES
LINEAR: X = ±0.5
 XX = ±0.1
 XXX = ±0.05
ANGULAR: X = 1°
 XX = ±0.2°

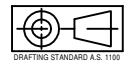

DRAFTING STANDARD A.S. 1105

SURFACE FINISHES MAX 1.6 MICRO METRES

This drawing remains the property of originator.
No part or parts of this drawing may be reproduced without
written permission.

MAT'L		
FINISH PVC		
DRAWN	RCIESLAK	22/06/2009
CHECKED		
RELEASED		
SCALE		

HURLCON
P / L

Ph 9701 5562 Fax 9701 5572
ABN 97 007 284 504

48 Hanna Street, Noble Park, Vic 3179

FRAME	1" LIP WATERFALL - 600mm		
STATUS	SILKFLOW WATERFALL		
R	CAM / LYT. NO. 1CAM		
SHEET	DWG. NO:	DATA CARE NO:	REVISION
A3	10271		B

REV	CHANGE DESCRIPTION	DATE	BY
-	-	-	-