

1 2 3 4 5 6 7 8

A

B

C

D

E

F

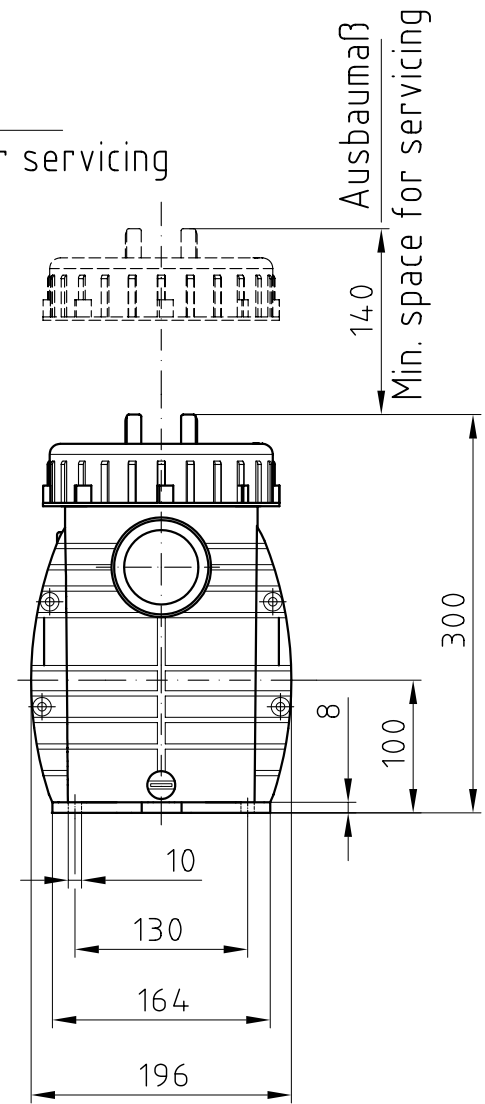
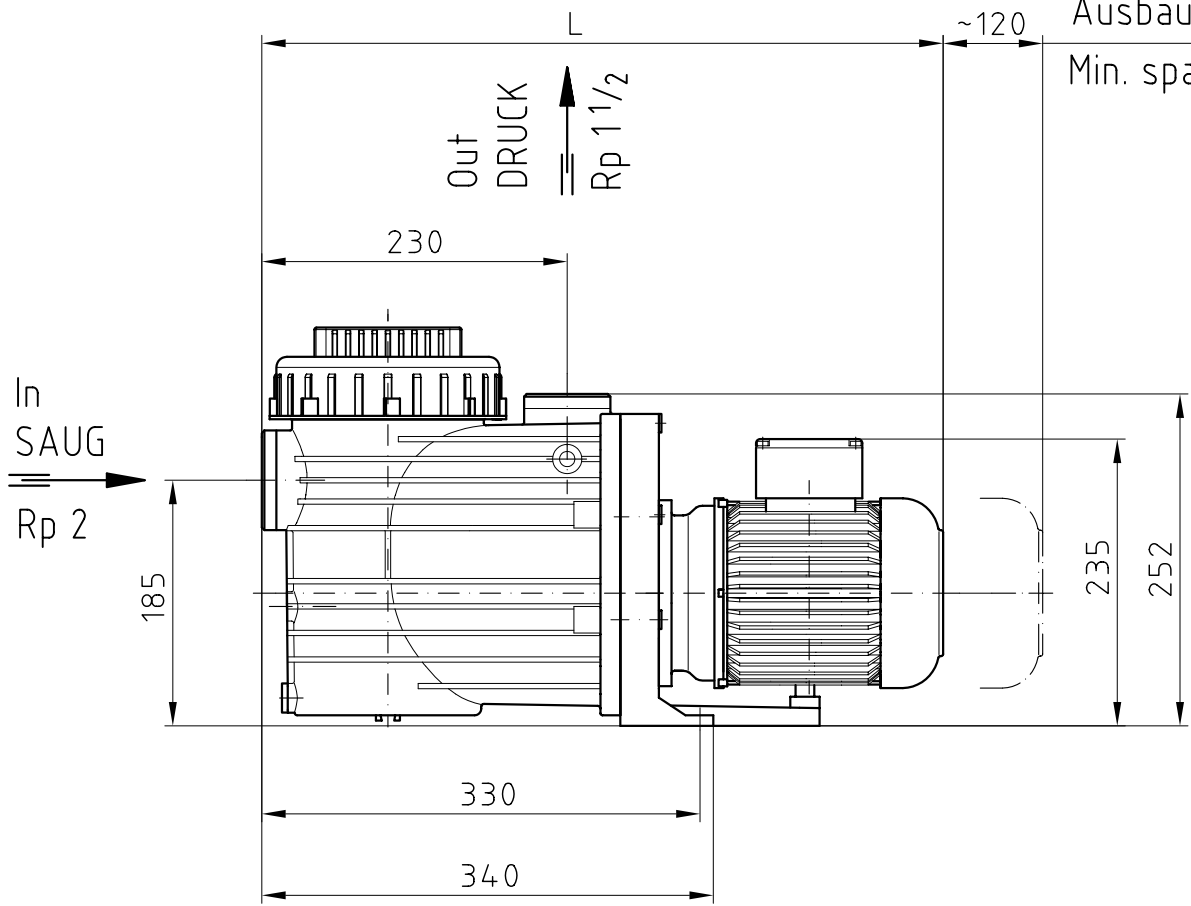

Typ	Gilt auch für:		L
BADU TOP 6		1~	470
BADU TOP 8	BETTAR 8	1~ 3~	490
BADU TOP 12	BETTAR 12	1~ 3~	490
BADU TOP 14	BETTAR 14	1~ 3~	505
BADU TOP 20		1~ 3~	525 / 510
BADU TOP 25		1~ 3~	525 / 520

Toleranzen DIN ISO 2768-m-K		Maßstab 1:4 (DIN A)	Position	Gewicht
Oberfläche $\sqrt{x} = 12,5$, $\sqrt{y} = 3,2$, $\sqrt{z} = 0,8$		Werkstoff Modell Nr.		
Datum	Name	Maßzeichnung BETTAR und BADU TOP BETTAR 8, 12 und 14 BADU TOP 6, 8, 12, 14, 20, 25		
Gez. 02.08.2007	B.I.			
Bearb.				
Gepr.		Zchnng. Nr. D90.04.222		
Zust. Änderungen		Datum	Name	Ers. f. D90.04.204
				Ers. d. 8



1 2 3 4 5 6 7 8