

# Nano SPA Heater

Installation & Operating Manual



**ELECR**

---

**ENGINEERING**

## Important Notes!

Thank you for purchasing the NANO Spa Heater manufactured in England to the highest standards.

To ensure your new heater will give years of trouble free service **please carefully read the following instructions.**

**Incorrect installation will affect your warranty.**

Do not discard this manual, please retain for future reference.

## Product Overview

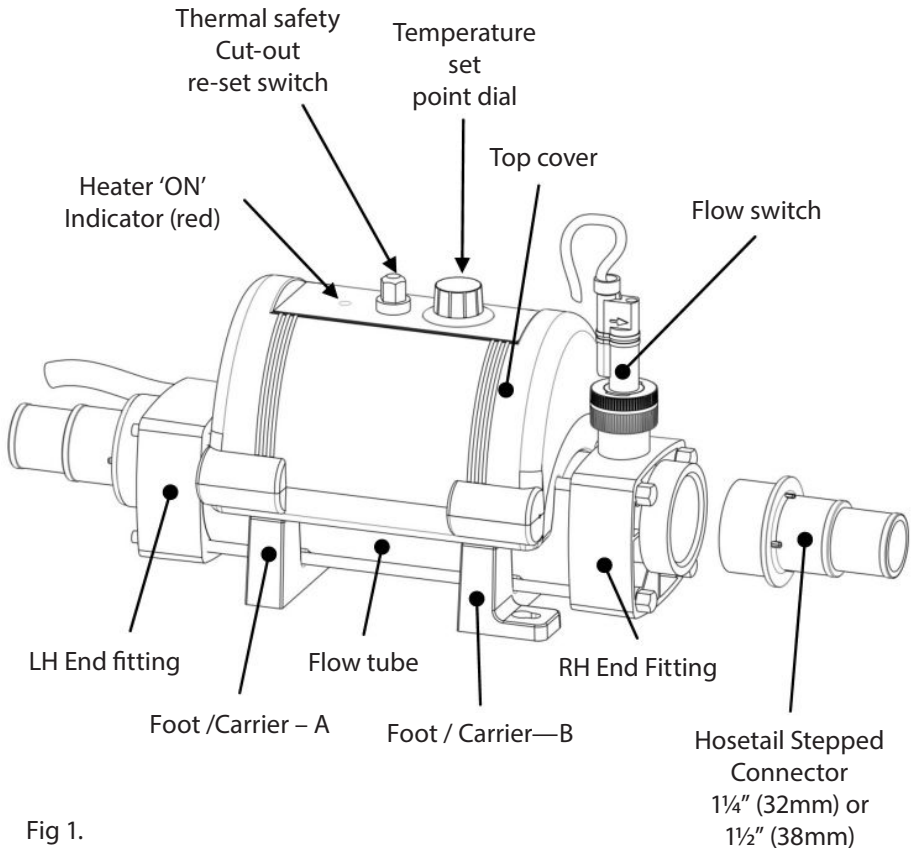

Fig 1.

**NOTE** unions for rigid pipe work not shown.

## Positioning

Your heater should be horizontally or vertically sited allowing sufficient space for pipe connections and wiring, it should be screw fixed securely to a firm base or wall.

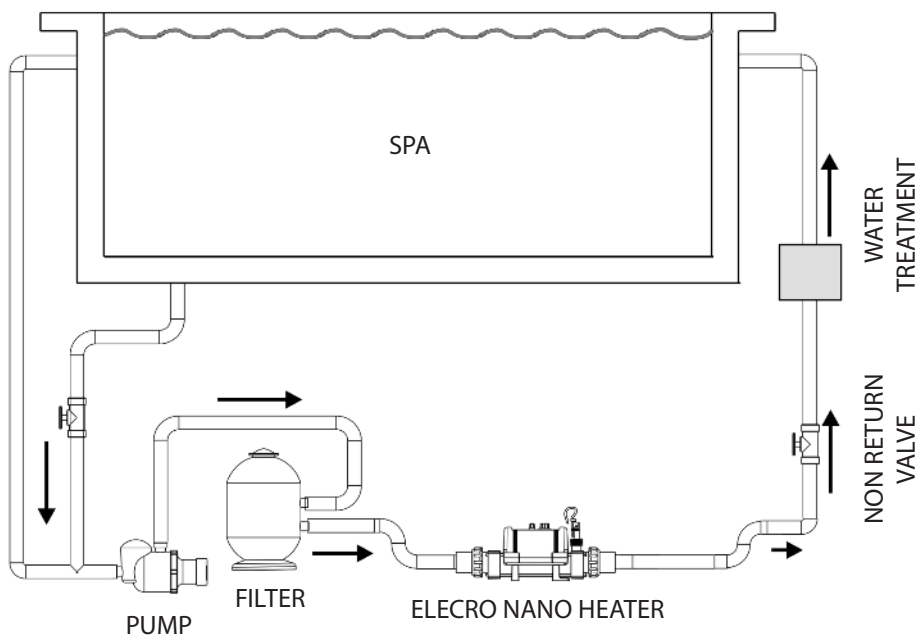

Fig 2.

The heater should be installed at a low point in the filtration system. It should be positioned downstream (after) of the filter and upstream (before) of any dosing or other water treatment plant. (see fig.2)

## Positioning (continued)

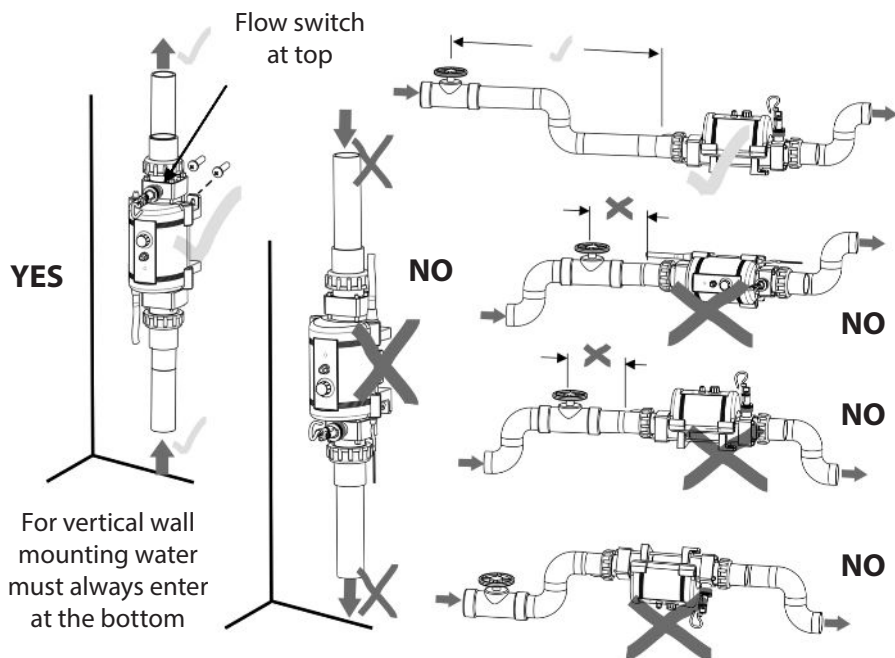

Fig 3.

## Pipe Work

It is essential that the pipe work connecting to and from the heater has a minimum bore (internal diameter) of 1¼" (32mm).

To assist correct air purging and to ensure the heater remains completely full of water during operation, the return pipe which carries the water back to the spa must incorporate a safety loop or 'kick-up' in the pipe as close as possible to the heater (see fig 3).

**NOTE: When coupling to flexible pipe a safety loop can simply be created by routing the pipe up and over an obstacle. Remember to use pipe clips to securely fasten all hose connections**

## Weather Protection

The heater must be installed within a dry weather proof enclosure.

**CAUTION!** If the heater is not used during winter months it must be drained to prevent frost damage.

## Electrical Connection

The heater must be installed in accordance with the country / regional requirements and regulations. In any event the work must be carried out by a qualified electrician, who will provide a certificate of conformity upon completion of the work.

**It is essential that the power supply to the heater is protected by a 30mA RCD (Residual Current Device). If in doubt consult a qualified Electrician.**

## Power Requirements

230V 1 Phase-Power Output	Load
1-kW	5-Amp
2-kW	9-Amp
3-kW	13-Amp
4-kW	18-Amp
5-kW	22-Amp
6-kW	27-Amp

## Flow Requirements

The flow rate of water into the heater **must not exceed 17,000 litres per hour** (3,740 UK gallons/hour) A higher flow rate **will** require the installation of a bypass to prevent damage to the heater element. The heater will not operate with a flow rate below 1,000 litres / hour (220 UK gallons/hour)

The water quality **must** be within the following limits:

PH 6.8 - 8.0; TA (Total alkalinity) 80—140ppm (parts per million)

Chloride Content MAX: 150 mg/litre

Free Chlorine: 2.0 mg/litre

Total Bromine: Max 4.5 mg/litre

TDS (Total Dissolved Solids) / Calcium hardness 200 - 1,000ppm

Nano SPA heaters are built with a titanium heating element, which are suitable for use on spas with a salt concentration up to 8000ppm (8g/litre). For salt concentrations over 8000ppm, a titanium flow tube is also recommended.

**Water chemistry is complicated if in doubt seek expert advise.**

## Operating Instructions

Upon completion of the installation, run the water-circulating pump to purge the system and heater of air (i.e. remove any trapped air in the system and heater). TIP: You can encourage air out of the heater flow tube by gently elevating the exit port of the heater when the pump is running. The heater will only switch 'On' (red light indicator illuminated) when the following criteria are met ie:

- Water circulating pump is 'On' delivering in excess of 1,000 litres / hour (220 UK gallons/hour)
- Temperature set point dial is set to a higher value than that of the water

**Q:** *How long will it take to heat my spa?*

**A:** Assuming no heat losses, and a heater sized in the ratio 1.5-kW per 1,000 UK gallons of water (4,545-litres): it will take 2 days of continuous running to raise the temperature of a pool from tap temperature to swimming temperature. Heat loss will slow the heating process, particularly during periods of cold weather, hence the higher the water temperature is to be maintained above average ambient air temperature, the slower the heating process will become.

The only influencing factors are the level of insulation and the location of the pool with regard to wind shelter.

**Useful advice:** To reduce running costs and speed up the heating process; insulate the spa wherever possible. A cover when not in use is an essential minimum to retain heat.

## Trouble Shooting

### Heater will not switch 'On'

In most cases this will be the result of one of the following points not being met.

**Possible cause 1:** *The set point temperature has been achieved.*

To confirm increase the set point value by turning the temperature set point dial to a value greater than the current water temperature.

**Possible cause 2:** *The 'Thermal safety cut-out' has tripped.*

**Remedy:** Remove button cover and press red button to reset (see fig 4) If a positive click is felt, the cause of the tripping **must** be investigated and could be caused by a debris build-up or air pocket trapped inside the flow tube of the heater.

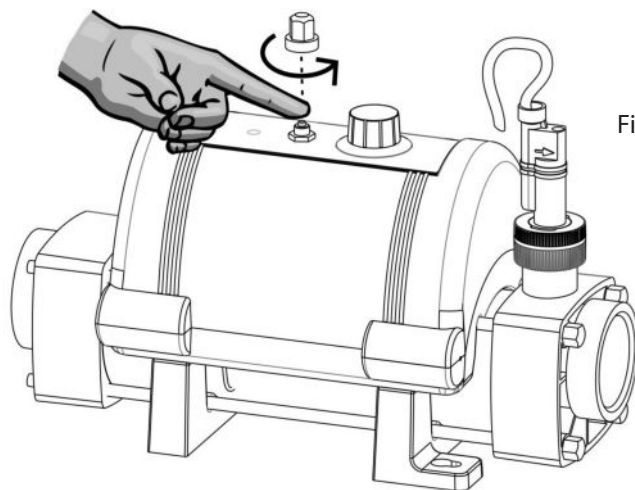

Fig 4.

**Possible cause 3:** *Insufficient flow.*

**If using a cartridge filter:** Confirm this by running the system with the cartridge removed from your pump and filter unit, this will supply the heater with the maximum flow rate your unit is capable of. If the heater then switches 'On' (ie: red light 'On') a blocked cartridge can be confirmed to be the cause. The cartridge should be cleaned or replaced.

**If using a sand filter:** Check the pressure indicator on your sand filter and back wash if necessary.

**Note: In some cases the 'Thermal safety cut-out' tripping and a low flow rate can be linked ie: when a filter becomes choked air can be drawn into the filtration system and become trapped inside the heater so causing the thermal cut-out to trip.**

## Quick Function Test

Observe the main electricity meter when the heater is on (ie: red light 'On') and then observe it again when the red light is off. The test should show that the meter is recording more electricity being used by the heater when the red light is 'On'.

It is impossible for an electric heater to waste energy, if it is drawing power then that power will be turned into heat that will be transferred to the water.

## Accurate Function Test

If a more accurate test is required to confirm that your heater is delivering the specified heat output, two electricity meter readings will need to be taken from the properties main electricity meter, with an exact one hour interval (ie: take one meter reading and then a second reading exactly one hour later) then by subtracting the first reading from the second reading the number of units (kilo watts kW) consumed can be calculated.

Note that your heater is also rated in kW hours. The spa pump and heater will need to be running continuously during the test (ie: with the heater red light 'On') To avoid inaccurate results when performing this test, it is important to refrain from using other high current consuming appliances in the property (such as tumble dryer, showers, cookers etc).

A large domestic spa pump of 1 horsepower will draw less than 1-kW in a one hour period. The conclusion of the test should prove that for example a 6-kW heater and a ½ horsepower pump will draw between 6.3-kW ~ 6.5-kW in one hour. It is impossible for an electric heater to waste energy, if it is drawing power then that power will be turned into heat that will be transferred to the water.



### The flow tube does not feel warm

Due to the high efficiency of your electric heater no warmth should be detectable from the flow tube of the heater. The most likely causes of the flow tube feeling warm are:-

**Possible cause 1:** The heater has been positioned in direct sunlight.

**Possible cause 2:** An air pocket is trapped inside the heater particularly if the tank feels warmer at the highest point of the tank (as air rises).

### The water entering my spa does not feel much warmer

The temperature gain of the water after it has passed through the heater will be directly proportional to the volume of water being pumped in relationship to the power output of the heater.

**For example:** A 6-kW heater, when connected to a 4,000 litre / hour pump, will produce a lift in temperature of approximately 1.2°C (almost undetectable to the human hand) however, as the water being heated is re-circulated from a single body of water, the time required to heat it remains unaffected by the volume of flow. A popular misconception is that slowing down the flow rate will speed up the heating process.

## RoHS Compliance Statement

Elecro Engineering Limited certify that our Electric Spa Heater Range complies in accordance with RoHS Directive 2011/65/EU on the restriction of hazardous substances.

## Waste of Electrical / Electronic Equipment

This product complies with EU directive 2012/19/EU

**Do Not dispose of this product as unsorted municipal waste.**



This symbol on the product or on its packaging indicates that this product should not be treated as household waste. Instead it should be handed over to the applicable collection point for the recycling of electrical and electronic equipment.

By ensuring this product is disposed of correctly you will help prevent potential negative consequences for

the environment and human health, which could otherwise be caused by inappropriate waste handling of this product. The recycling of materials will help to conserve natural resources. For more information please contact your local Civic office, your household waste disposal service or the retailer where you purchased the product.

## Guarantee

***Your heater is guaranteed for 2 years from the date of purchase against faulty workmanship and materials.***

The manufacturer will replace or repair, at its discretion, any faulty units or components returned to the company for inspection. Proof of purchase may be required.

The manufacturer will not be liable in cases of incorrect installation of the heater, inappropriate use or neglect of the heater.



11 Gunnels Wood Park | Stevenage | Hertfordshire | SG1 2BH | United Kingdom

**t:** +44 (0) 1438 749 474 | **f:** +44 (0) 1438 361 329 | **e:** sales@electro.co.uk

**[www.electro.co.uk](http://www.electro.co.uk)**